

# ФИТИНГИ

С ДВОЙНЫМ ОБЖИМОМ

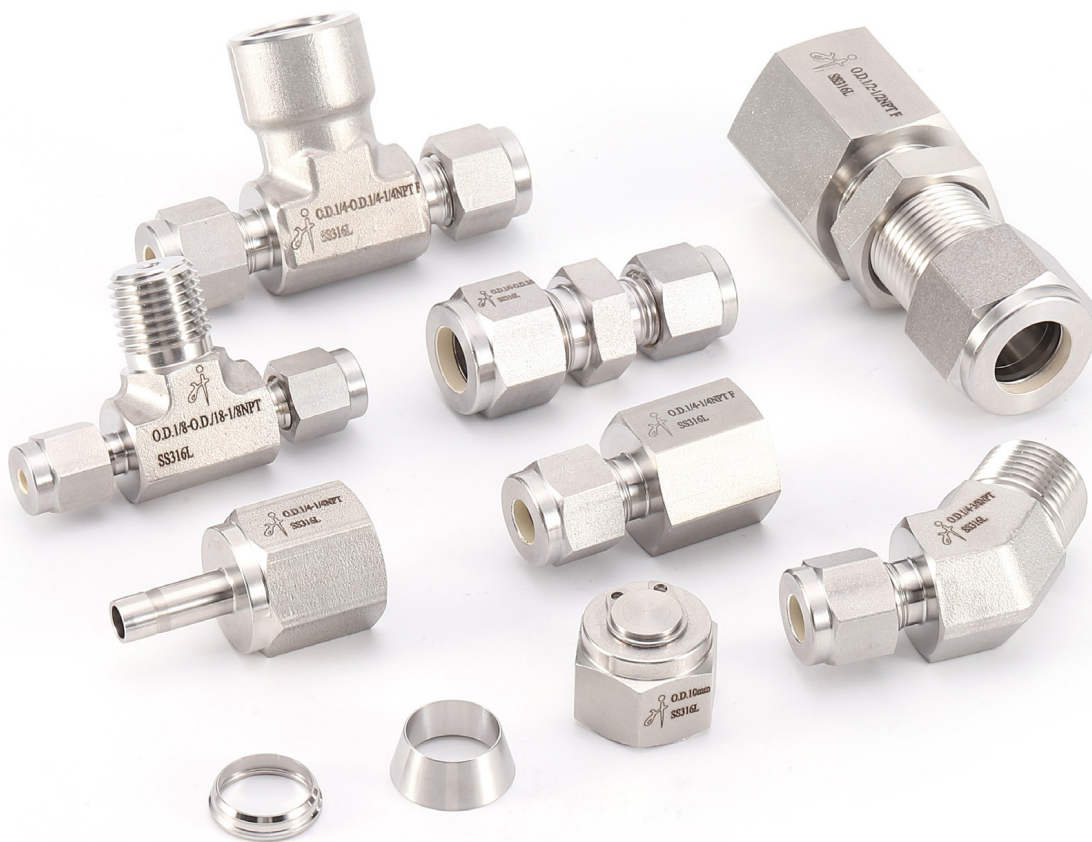



## О НАС

Торгово-производственная компания «ЭНЕРГОТЕХПРОМ» приветствует Вас! С 2023 года компания «ЭНЕРГОТЕХПРОМ» в сотрудничестве с китайской компанией Hongji активно развивает импортозамещение в России соединительной и запорной инструментальной арматуры для гидравлических и пневматических систем высокого давления под собственным брендом U-LOK. Наши производственные мощности находятся в России и Китае, а широкая сеть наших представителей и отлаженная логистика позволяют обеспечить поставки продукции в сжатые сроки по всей территории РФ.

В номенклатуру U-LOK входит следующая продукция:







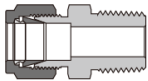
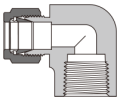
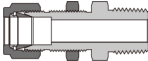

- трубные фитинги (обжимные с 2 кольцами, резьбовые, приварные);
- быстроразъемные соединения (БРС);
- импульсные трубы из нержавеющей стали;
- шаровые краны;
- игольчатые клапаны;
- обратные клапаны;
- предохранительные клапаны;
- манифольды;
- регуляторы давления;
- пробоотборные цилиндры;
- инструмент и монтажные аксессуары.

Компания «ЭНЕРГОТЕХПРОМ» была основана в 2023 году и за короткий срок зарекомендовала себя как надежный партнер и поставщик трубной арматуры. Мы поддерживаем тесные деловые отношения с многими ведущими промышленными предприятиями России в таких сферах как: добыча и переработка нефти и газа, нефтехимия, энергетика, машиностроение, судостроение, научно-исследовательский сектор, альтернативные виды топлива, производство полупроводников и другие. Наша цель направлена на эффективное использование производственных процессов и ресурсов для предоставления клиентам лучших продуктов и услуг.

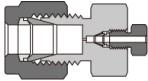
Компания «ЭНЕРГОТЕХПРОМ» гарантирует высокое качество продукции U-LOK. Для получения коммерческого предложения или технической консультации пришлите пожалуйста запрос на электронную почту [zakaz@et-prom.ru](mailto:zakaz@et-prom.ru)

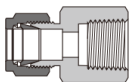
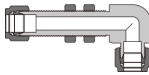
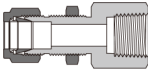
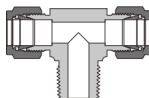
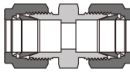
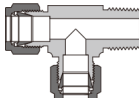
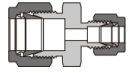
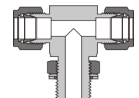
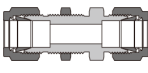
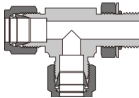
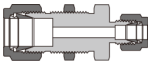
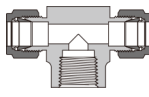
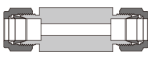
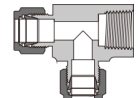
 **U-LOK** зарегистрированный бренд.

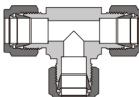
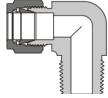
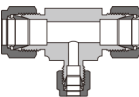
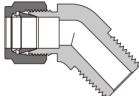
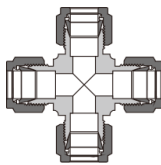
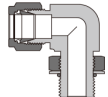
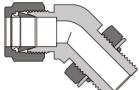
# Содержание

	Штуцер с наружной резьбой — FHM	13		Угольник с внутренней резьбой — FYW	47
	Штуцер с наружной резьбой и монтажной гайкой — FHMN	25		Угольник проходной — FYP	48
	Муфта конечная — FURE	27		Угольник переходной — FYR	49
	Штуцер с внутренней резьбой — FHW	28		Угольник проходной с монтажной гайкой FYPN	50
	Штуцер с внутренней резьбой и монтажной гайкой — FHW-N	33		Тройник ввертный с наружной резьбой — FTM	51
	Муфта проходная — FUP	34		Тройник с боковым отводом с наружной резьбой — FTSM	52
	Муфта переходная — FUR	35		Тройник ввертный с наружной резьбой с монтажной гайкой — FTMN	53
	Муфта проходная с монтажной гайкой — FUPN	37		Тройник с боковым отводом с наружной резьбой с монтажной гайкой — FTSMN	54
	Муфта переходная с монтажной гайкой — FURN	38		Тройник ввертный с внутренней резьбой — FTW	55
	Муфта проходная под приварку — FUPG	39		Тройник с боковым отводом с внутренней резьбой — FTSW	56
	Монтажная гайка — FN	39		Тройник проходной — FTP	57
	Угольник с наружной резьбой — FYM	40		Тройник переходной — FTR	58
	Угольник 45 с наружной резьбой — FY45M	43		Крестовина проходная — FKP	60
	Угольник с наружной резьбой с монтажной гайкой — FYMN	44			
	Угольник 45 с наружной резьбой с монтажной гайкой — FY45MN	46		Заглушка для трубки — FD	60

	Заглушка для фитинга — FDD	61		Соединение для проходного канала — FEP	68
	Фильтр защитный для вентиляционных отверстий — FF	61		Переходник для проходного канала — FER	69
	Соединитель лабораторных фланцев — FUU	61		Переходник с наружной резьбой — FEM	70
	Гайка — FW	62		Переходник с внутренней резьбой — FEW	75
	Гайка с накаткой — FWJ	62		Адаптер под приварку — FLG	78
	Гайка с наружной резьбой — FWM	62		Адаптер фланцевый — FL	79
	Кольцо обжимное переднее — FA	63		Муфта под приварку — FUG	81
	Кольцо обжимное заднее — FB	63		Угольник для приварки — FYG	82
	Комплект обжимных колец с гайкой — FABN	64		Фитинг калибровочный — FUC	83
	Комплект обжимных колец — FAB	64		Прокладка RS — FV1	84
	Переходник — FE	65		Прокладка RP — FV2	84
	Переходник с монтажной гайкой — FEN	67		Прокладка RG — FV3	85
	Угольник переходной трубный — FEY	67		Прокладка RJ — FV4	85
	Втулка для гибких трубок — FEX	68		Кольцо уплотнительное — FV	xx

## Описание

- Размеры фитингов варьируются от 1/16" до 2" и от 2 mm до 50 mm
- Твердость трубы из нержавеющей стали: Бесшовные трубы из стали 304L и L с высоким отпуском по номенклатуре ASTM A269 или эквивалентные им с твердостью по Роквеллу RB85 скатанные в катушках или прямолинейном виде
- Используется резьба полученная методом прокатки, а не токарной обработки, что делает ее более гладкой и предотвращает истирание
- Внутренняя резьба гаек посеребрена для уменьшения трения о резьбу корпуса.
- Кованый корпус для угольников, тройников или крестовин обеспечивает усиление корпуса и стойкость к давлению.
- Доступны различные материалы: нержавеющая сталь марки 304L, 316L, сталь, латунь, алюминий и другие (см. таблица стр. 8)
- На каждом фитинге указан размер, материал и номер производителя.

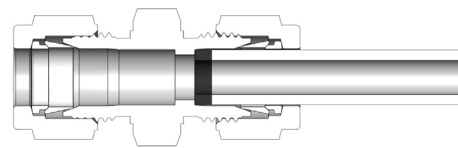

## Испытания

- Испытание на гидравлическую утечку (в 1,5 раза превышающее максимально допустимое рабочее давление): утечки нет.
- Испытание на минимальное гидростатическое давление (в 4 раза превышающее максимально допустимое номинальное давление окружающей среды): отсутствие утечек.
- Пневматическое испытание при вибрации под давлением (частота вибрации на уровне 45 Гц : утечки отсутствуют)
- Испытание на огнестойкость (в соответствии с BS ISO 19921): утечки отсутствуют
- Испытание на коррозионную стойкость (продолжительность воздействия не менее 168 ч): видимых признаков коррозии нет.
- Тест на разборку и сборку (разборка-сборка десять раз): утечки отсутствуют
- обнаружение трещин (оптический осмотр под микроскопом): видимых трещин не обнаружено.

## Техническая информация

- Тип резьбы.

### Коническая резьба (NPT)

- ГОСТ 6111-52 ASME 81.20.1, SAEAS71051.

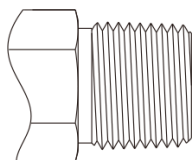

- Угол резьбы 60 градусов
- Шаг резьбы в дюймах
- Конусность 1:16
- Тип уплотнения — резьбовой герметик

### Характеристики резьбы

Размер резьбы	Число витков на дюйм	Диаметры резьбы в основной плоскости(мм)			Длина резьбы	
		Наружный диаметр, мм	Средний диаметр, мм	Внутренний диаметр, мм	мм	Витки
1/16	27	7.894	7.142	6.389	4.064	4.32
1/8		10.242	9.489	8.737	4.102	4.36
1/4	18	13.616	12.487	14.797	5.785	4.10
3/8		17.055	15.926	18.321	6.096	4.32
1/2	14	21.224	19.772	18.321	8.128	4.48
3/4		26.569	25.117	23.666	8.618	4.75
1	11.5	33.228	31.461	29.694	10.160	4.60
1 1/4		41.985	40.218	38.451	10.668	4.83
1 1/2		48.054	46.287	44.520	10.668	4.83
2		60.092	58.325	56.558	11.065	5.01

## Рабочее давление для резьбы NPT

Размер резьбы	Нержавеющая сталь 316L , Углеродистая сталь				Латунь			
	наружная резьба		внутренняя резьба		наружная резьба		внутренняя резьба	
	psig	bar	psig	bar	psig	bar	psig	bar
1/16	11000	757	6700	460	5500	378	3300	227
1/8	10000	690	6500	447	5000	344	3200	220
1/4	8000	551	6600	454	4000	275	3300	227
3/8	7800	537	5300	365	3900	268	2600	179
1/2	7700	530	4900	337	3800	261	2400	165
3/4	7300	502	4600	316	3600	248	2300	158
1	5300	365	4400	303	2600	179	2200	151
1 1/4	6000	410	5000	344	3000	200	2500	172
1 1/2	5000	344	4600	317	2500	172	2300	158
2	3900	268	3900	268	1900	130	1900	130

Рабочее давление основано на ANSI/ASME B31.3 при температуре окружающей среды.

## Коническая резьба (R, R1, R2, RC, RT, PT, BSPT, ZG)

- Соответствует ISO 7-1, EN 10226-1, BS 21, DIN 2999, JIS B0203.

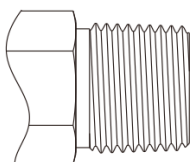

- Угол резьбы 55 градусов
- Шаг резьбы в дюймах
- Конусность 1:16
- Тип уплотнения — резьбовой герметик

### Характеристики резьбы

Размер резьбы	Число витков на дюйм	Диаметры резьбы в основной плоскости(мм)			Длина резьбы	
		Наружный диаметр, мм	Средний диаметр, мм	Внутр. диаметр, мм	мм	Витки
1/16	28	7.723	7.142	6.561	4.0	4.4
1/8		9.728	9.147	8.566	4.0	4.4
1/4	19	13.157	12.301	11.445	6.0	4.5
3/8		16.662	15.806	14.950	6.4	4.8
1/2	14	20.955	19.793	18.631	8.2	4.5
3/4		26.441	25.279	24.117	9.5	5.2
1	11	33.249	31.770	30.291	10.4	4.5
1 1/4		41.910	40.431	38.952	12.7	5.5
1 1/2		47.803	46.324	44.845	12.7	5.5
2		59.614	58.135	56.656	15.9	6.9

## Параллельная резьба ISO (G , RP, PF, BSPP)

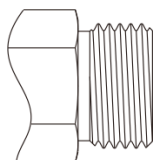

- Угол резьбы 55 градусов
- Шаг резьбы в дюймах

### Характеристики резьбы

Размер резьбы	Число витков на дюйм	Диаметры резьбы в основной плоскости(мм)		
		Наружный диаметр, мм	Средний диаметр, мм	Внутр. диаметр, мм
1/16	28	7.723	7.142	6.561
1/8		9.728	9.147	8.566
1/4	19	13.157	12.301	11.445
3/8		16.662	15.806	14.950
1/2	14	20.955	19.793	18.631
5/8		22.911	21.749	20.587
3/4		26.441	25.279	24.117
7/8		30.201	29.039	27.877
1	11	33.249	31.770	30.291
1 1/8		37.897	36.418	34.939
1 1/4		41.910	40.431	38.952
1 1/2		47.803	46.324	44.845
1 3/4		53.746	52.267	50.788
2		59.614	58.135	56.656

# Типы уплотнений для цилиндрической резьбы ISO

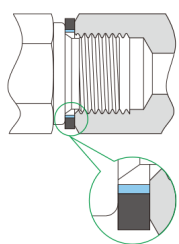

## 1. RS Stud End, RS Gasket and RP Port

- RS stud end complies with DIN 3852-2 type A
- For RS gasket
- RP port complies with DIN 3852-2 type X

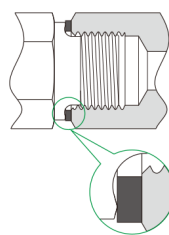

## 2. RP Stud End, RP Gasket and RP Port

- RP stud end complies with DIN 3852-2 type B
- For RP gasket
- RP port complies with DIN 3852-2 type X

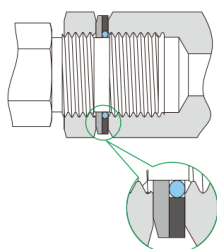

## 3. PP Stud End and RP Port

- PP Stud end complies with ISO 1179-3
- RP port complies with DIN 3852-2 type X

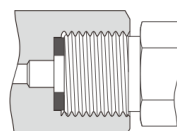

## 4. Соединение RG, Прокладка RG и резьба ВР

- Соединение RG соответствует EN 837-1/3
- С прокладкой RG

### Рабочее давление цилиндрической резьбы ISO (PP)

Размер резьбы	Нержавеющая сталь 316	
	psig	bar
1/8	4568	315
1/4		
3/8		
1/2	2320	160
3/4		
1		

### Резьба SAE/MS (UN, UNJ)

- Соответствует ASME B 1.1, ISO R725.

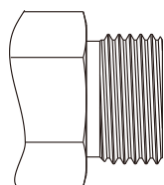

- Угол резьбы 60 градусов
- Шаг резьбы в дюймах

### Характеристики резьбы

Размер резьбы	Число витков на дюйм	Диаметры резьбы в основной плоскости(мм)		
		Наружный диаметр, мм	Средний диаметр, мм	Внутренний диаметр, мм
5/16-24	24	7.938	7.249	6.792
3/8-24	24	9.525	8.837	8.380
7/16-20	20	11.113	10.287	9.738
1/2-20	20	12.700	11.875	11.326
9/16-18	18	14.288	13.325	12.761
3/4-16	16	19.050	18.019	17.330
7/8-14	14	22.225	21.046	20.262
1 1/16-12	12	26.988	25.613	24.719
1 3/16-12	12	30.163	28.788	27.871
1 5/16-12	12	33.338	31.963	31.046
1 5/8-12	12	41.275	39.901	38.984
1 7/8-12	12	47.625	46.251	45.324
2 1/2-12	12	63.500	62.126	61.209



# Типы уплотнений для резьбы SAE/MS

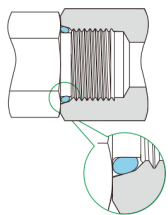

## 1. Резьба ST SAE J1926-1

- Соединение ST соответствует SAE J1926-3
- С уплотнительным кольцом

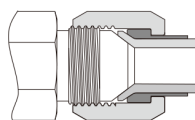

## 2. Резьба с уплотнительным конусом 37 (AN) и развальцованная трубка

- Тип уплотнения соответствует SAE J514

### Рабочее давление для резьбы SAE/MS

SAE Номинальный размер	Размер Резьбы	Нержавеющая сталь 316L, Углеродистая сталь			
		psig	bar	psig	bar
2	5/16-24	5075	350	5075	350
3	3/8-24			4568	315
4	7/16-20			4060	280
5	1/2-20				
6	9/16-18				
8	3/4-16	4568	315		
10	7/8-14	3626	250	3045	210
12	1 1/16-12				
14	1 3/16-12	3045	210	2538	175
16	1 5/16-12				
20	1 5/8-12	2538	175	2030	140
24	1 7/8-12				
32	2 1/2-12	2030	140	1523	105

Рабочее давление основано на SAE J1926-3 при температуре окружающей среды.

### Метрическая резьба (M)

- Соответствует ISO 261.

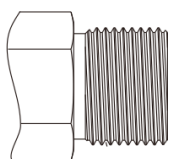

- Угол резьбы 60 градусов
- Размер резьбы в мм

### Характеристики резьбы

Размер резьбы	Шаг резьбы, мм	Basic Dia		
		Max. Dia	Pitch Dia	Min. Dia
M6 × 1	1	6.000	5.350	4.917
M8 × 1		8.000	7.350	6.917
M10 × 1		10.000	9.350	8.917
M12 × 1.5	1.5	12.000	11.026	10.376
M14 × 1.5		14.000	13.026	12.376
M16 × 1.5		16.000	15.026	14.376
M18 × 1.5		18.000	17.026	16.376
M20 × 1.5		20.000	19.026	18.376
M22 × 1.5		22.000	21.026	20.376
M24 × 1.5		24.000	23.026	22.376
M27 × 2	2	27.000	25.701	24.835
M30 × 2		30.000	28.701	27.835
M33 × 2		33.000	31.701	30.835
M36 × 2		36.000	34.701	33.835
M39 × 2		39.000	37.701	36.835
M42 × 2		42.000	40.701	39.835
M45 × 2		45.000	43.701	42.835
M48 × 2		48.000	46.701	45.835

## Типы уплотнений для метрической резьбы

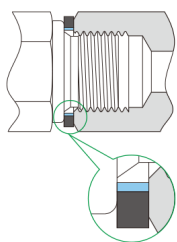

### 1. MRS Stud End, RS-M gasket and MS Port

- MRS stud end complies with DIN 3852-1 type A
- For RS-M gasket

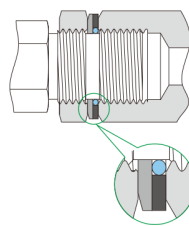

### 2. MS Stud End, RG-M gasket and MS Port

- For RG-M gasket

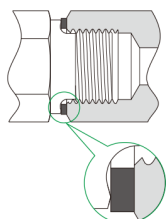

### 3. MST Stud End and ISO 6149-1 Port

- MST stud end complies with ISO 6149-3
- For O-ring

### Рабочее давление метрической резьбы MST

Размер резьбы	Нержавеющая и углеродистая сталь			
	Непозиционируемая		Позиционируемая	
	psig	bar	psig	bar
M8 × 1	5800	400	4568	315
M10 × 1				
M12 × 1.5				
M14 × 1.5				
M16 × 1.5	4568	315	3626	250
M18 × 1.5				
M22 × 1.5				
M27 × 2	2900	200	2320	160
M30 × 2				
M33 × 2				
M42 × 2				
M48 × 2				
M60 × 2	2320	160	1450	100

### Рабочая температура

Рабочая температура резьбы может быть ограничена тефлоновой лентой или резьбовым герметиком, а также если применяемыми, прокладками или уплотнительными кольцами следующим образом:

Компонент	Материал	Минимальная температура	Максимальная температура
Прокладка RP/RG	Резина N	-13°F (-25°C)	230°F (110°C)
	Фторкаучук FKM	5°F (-15°C)	400°F (204°C)
прокладка RP/RG	Медь	-325°F (-198°C)	400°F (204°C)
	Нержавеющая сталь	-425°F (-254°C)	1 000°F (538°C)
Прокладка RG	PTFE	-65°F (-54°C)	450°F (232°C)
	Пластик	-76°F (-60°C)	221°F (105°C)
Кольцо уплотнительное	Резина N	-22°F (-30°C)	230°F (110°C)
	Фторкаучук FKM	-4°F (-20°C)	400°F (204°C)

## Рабочее давление

1. Рабочие характеристики температуры и давления разработаны и протестированы в соответствии со стандартами ASTM и EN
2. Максимальное рабочее давление резьб при температуре окружающей среды указано выше .
3. Рабочее давление фитинга указывается как самое низкое рабочее давление на всех концах соединений системы.

Материал	пруток	Поковка	Обозначение
Нержавеющая сталь 316	ASTMA479 ASME SA479 EN 1.4401	ASTMA182 ASME SA182 EN 1.4401	SS
Нержавеющая сталь 316L	ASTMA479 ASME SA479 EN 1.4404	ASTMA182 ASME SA182 EN 1.4404	SL
Нержавеющая сталь 304	ASTMA479 ASME SA479 EN 1.4301	ASTMA182 ASME SA182 EN 1.4301	S4
Нержавеющая сталь 321	ASTMA479 ASME SA479 EN 1.4541	ASTMA182 ASME SA182 EN 1.4541	S21
Нержавеющая сталь 316Ti	ASTMA479 ASME SA479 EN 1.4571	ASTMA182 ASME SA182 EN 1.4571	S6T
Нержавеющая сталь сплава 254SMO	ASTMA479	ASTMA182	S12
Нержавеющая сталь 904L	ASTMA479	ASTMA182	904L
Титан (класс 4)	ASTM B348	ASTM B381	TL
Дуплекс 2205	ASTMA479	ASTMA182	022
Супер дуплекс 2507	ASTMA479	ASTMA182	025
Сплав 20	ASTMA479	ASTM B462	A20
Сплав 400	ASTM B16 4 ASME SB164	ASTM B564 ASMESB564	M4
Сплав 600	ASTM B166 ASME SB166	ASTM B564 ASMESB564	INC6
Сплав 625	ASTM B446	ASTM B564 ASMESB564	A62
Сплав 718	ASTM B637	ASTM B6 37	A718
Сплав 825	ASTM B425	ASTM B564	A825
Hastelloy C-276	ASTM B574	ASTM B564	HC
Углеродистая сталь	ASTMA1 08	ASTMA105	CS
Бронза	ASTM B16/B453	ASTM B283	MS
Нейлон	ASTM 04066	/	PA
PTFE	ASTM 01710	/	P

## Таблица составления артикула

FYM		YZ8		NPT8		RT9		SS	
Тип Фитинга		P1 Тип	P1 Размер	P2 Тип	P2 Размер	P3 и P4	Материал		
FHM	Штуцер с наружной резьбой	GZ	1 1/16"	Включает в себя тип P1 и следующие:	5 M5 × 0.8 или 5/16-24	Тоже что и P2	SS	Нержавеющая сталь 316	
FHM-N	Штуцер с наружной резьбой и монтажной гайкой	YZ	2 1/8" или 2мм	NPT Резьба NPT	6 M6 × 1 или 3/8-24		SL	Нержавеющая сталь 316L	
FHW	Штуцер с внутренней резьбой	MT	3 3/16" или 3мм	ON Резьба NPT с кольцом	7 7/16-20	S4	Нержавеющая сталь 304		
FHW-N	Штуцер с внутренней резьбой и монтажной гайкой	FT	4 1/4" или 4мм	RT Коническая резьба ISO	8 M8 × 1 или 1/2-20	SZ1	Нержавеющая сталь 321		
FUP	Муфта проходная		5 5/16"	RS Коническая резьба ISO (RS)	9 9/16-18	S12	Нержавеющая сталь сплава 254SMO		
FUP-N	Муфта проходная с монтажной гайкой		6 3/8" или 6мм	RP Цилиндрическая резьба ISO (RP)	10 M10 × 1	904L	Нержавеющая сталь 904L		
FYM	Угольник с наружной резьбой		8 1/2" или 8мм	RJ Цилиндрическая резьба ISO (Japanese)	12 M12 × 1.5 или 3/4-16	T1	Титан		
FY45M	Угольник 45 с наружной резьбой и монтажной гайкой		10 5/8" или 10мм	RG Цилиндрическая резьба ISO (измеряемая)	14 M14 × 1.5 или 7/8-14	D22	Дуплекс 2205		
FYM-N	Угольник с наружной резьбой и монтажной гайкой		12 3/4" или 12мм	RJ Цилиндрическая резьба ISO (Japanese)	16 M16 × 1.5	D25	Супер дуплекс 2507		
FYP	Угольник проходной		14 7/8" или 14мм	PR Positionable, ISO Parallel Thread	17 1 1/16-12	A20	Сплав 20		
FYP-N	Угольник проходной с монтажной гайкой		15 15 мм	ST Прямая резьба SAE/MS	18 M18 × 1.5	M4	Сплав 400		
FTSM	Тройник с боковым отводом с наружной резьбой		16 1" или 16мм	OST Прямая резьба SAE/MS с кольцом	19 1 3/16-12	INC6	Сплав 600		
FTSM-N	Тройник с боковым отводом с наружной резьбой и монтажной гайкой		18 1 1/8" или 18мм	AN Уплотнительный конус 37	20 M20 × 1.5	A62	Сплав 625		
FTSW	Тройник с боковым отводом с внутренней резьбой		20 1 1/4" или 20мм	MS Наружная метрическая резьба	21 1 5/16-12	HC	Hastelloy C-276		
FTP	Тройник проходной		22 22мм	TS Приварка в раструб	22 M22 × 1.5	cs	Углеродистая сталь		
FKP	Крестовина проходная		24 1 1/2" или 24мм	PB Приварка стыковая	24 M24 × 1.5	MS	Бронза		
FD	Заглушка для трубки		25 25мм		26 1 5/8-12	PA	Нейлон		
FDD	Заглушка для фитинга		28 28мм		27 M27 × 2	P	PTFE		
FE	Переходник		30 30мм		30 1 7/8-12				
FEP	Соединение для проходного канала		32 2" или 32мм						
FEM	Переходник с наружной резьбой		38 38мм						
FEW	Переходник с внутренней резьбой		50 50мм						
FU-G	Муфта под приварку								
FY-G	Угольник под приварку								

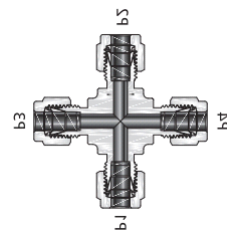

- P1, P2, P3 и P4 описываются в следующем порядке:
- Обжим· Труба· Резьба NPT • Коническая резьба ISO· Цилиндрическая резьба ISO· Прямая резьба SAE/MS · Уплотнительный конус 37· Приварка стыковая Weld· Приварка в раструб • Другое
- Опишите в порядке убывания размеры , если все соединения одинаковые
- Опишите P1 , если все соединения одинаковые

# Размеры

Размеры приведены для справки и могут отличаться.

## Штуцер с наружной резьбой

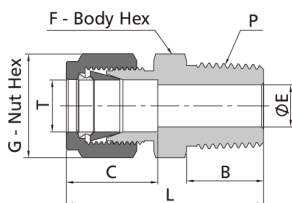

Размер E наименьший номинальный размер.

Дюймовая трубка			Резьба NPT					
Т-трубка O.D. (дюйм.)	Размер резьбы NPT	Артикул	Размеры, дюймы мм]					
			L	B	C	E	G	F
1/16	1/16	FHM-YZ1-NPT1-	0.94(23.9)	0.38(9.7)	0.34(8.6)	0.05(1.3)	0.31(7.9)	0.31(7.9)
1/16	1/8	FHM-YZ1-NPT2-	1.03(26.2)	0.38(9.7)	0.34(8.6)	0.05(1.3)	0.31(7.9)	0.44(11.1)
1/16	1/4	FHM-YZ1-NPT4-	1.22(31.0)	0.56(14.2)	0.34(8.6)	0.05(1.3)	0.31(7.9)	0.56(14.3)
1/8	1/16	FHM-YZ2-NPT1-	1.17(29.7)	0.38(9.7)	0.50(12.7)	0.09(2.3)	0.44(11.1)	0.44(11.1)
1/8	1/8	FHM-YZ2-NPT2-	1.20(30.5)	0.38(9.7)	0.50(12.7)	0.09(2.3)	0.44(11.1)	0.44(11.1)
1/8	1/4	FHM-YZ2-NPT4-	1.40(35.6)	0.56(14.2)	0.50(12.7)	0.09(2.3)	0.44(11.1)	0.56(14.3)
1/8	3/8	FHM-YZ2-NPT6-	1.41(35.8)	0.56(14.2)	0.50(12.7)	0.09(2.3)	0.44(11.1)	0.69(17.5)
1/8	1/2	FHM-YZ2-NPT8-	1.66(42.2)	0.75(19.1)	0.50(12.7)	0.09(2.3)	0.44(11.1)	0.87(22.2)
3/16	1/16	FHM-YZ3-NPT1-	1.23(31.2)	0.38(9.7)	0.54(13.7)	0.12(3.0)	0.50(12.7)	0.44(11.1)
3/16	1/8	FHM-YZ3-NPT2-	1.23(31.2)	0.38(9.7)	0.54(13.7)	0.12(3.0)	0.50(12.7)	0.44(11.1)
3/16	1/4	FHM-YZ3-NPT4-	1.43(36.3)	0.56(14.2)	0.54(13.7)	0.12(3.0)	0.50(12.7)	0.56(14.3)
1/4	1/16	FHM-YZ4-NPT1-	1.29(32.8)	0.38(9.7)	0.60(15.2)	0.12(3.0)	0.56(14.3)	0.50(12.7)
1/4	1/8	FHM-YZ4-NPT2-	1.29(32.8)	0.38(9.7)	0.60(15.2)	0.19(4.8)	0.56(14.3)	0.50(12.7)
1/4	1/4	FHM-YZ4-NPT4-	1.49(37.8)	0.56(14.2)	0.60(15.2)	0.19(4.8)	0.56(14.3)	0.56(14.3)
1/4	3/8	FHM-YZ4-NPT6-	1.51(38.4)	0.56(14.2)	0.60(15.2)	0.19(4.8)	0.56(14.3)	0.69(17.5)
1/4	1/2	FHM-YZ4-NPT8-	1.76(44.7)	0.75(19.1)	0.60(15.2)	0.19(4.8)	0.56(14.3)	0.87(22.2)
1/4	3/4	FHM-YZ4-NPT12-	1.82(46.2)	0.75(19.1)	0.60(15.2)	0.19(4.8)	0.56(14.3)	1.06(27.0)
5/16	1/8	FHM-YZ5-NPT2-	1.34(34.0)	0.38(9.7)	0.64(16.3)	0.19(4.8)	0.63(15.9)	0.56(14.3)
5/16	1/4	FHM-YZ5-NPT4-	1.52(38.6)	0.38(9.7)	0.64(16.3)	0.25(6.4)	0.63(15.9)	0.56(14.3)
5/16	3/8	FHM-YZ5-NPT6-	1.54(39.1)	0.56(14.2)	0.64(16.3)	0.25(6.4)	0.63(15.9)	0.69(17.5)
5/16	1/2	FHM-YZ5-NPT8-	1.79(45.5)	0.75(19.1)	0.64(16.3)	0.25(6.4)	0.63(15.9)	0.87(22.2)
3/8	1/8	FHM-YZ6-NPT2-	1.39(35.3)	0.38(9.7)	0.66(16.8)	0.19(4.8)	0.69(17.5)	0.63(15.9)
3/8	1/4	FHM-YZ6-NPT4-	1.57(39.9)	0.56(14.2)	0.66(16.8)	0.28(7.1)	0.69(17.5)	0.63(15.9)
3/8	3/8	FHM-YZ6-NPT6-	1.57(39.9)	0.56(14.2)	0.66(16.8)	0.28(7.1)	0.69(17.5)	0.69(17.5)
3/8	1/2	FHM-YZ6-NPT8-	1.82(46.2)	0.75(19.1)	0.66(16.8)	0.28(7.1)	0.69(17.5)	0.87(22.2)
3/8	3/4	FHM-YZ6-NPT12-	1.88(47.8)	0.75(19.1)	0.66(16.8)	0.28(7.1)	0.69(17.5)	1.06(27.0)
3/8	1	FHM-YZ6-NPT16-	2.14(54.4)	0.94(23.9)	0.66(16.8)	0.28(7.1)	0.69(17.5)	1.37(34.9)
1/2	1/8	FHM-YZ8-NPT2-	1.53(38.9)	0.38(9.7)	0.90(22.9)	0.19(4.8)	0.87(22.2)	0.81(20.6)
1/2	1/4	FHM-YZ8-NPT4-	1.71(43.4)	0.56(14.2)	0.90(22.9)	0.28(7.1)	0.87(22.2)	0.81(20.6)
1/2	3/8	FHM-YZ8-NPT6-	1.71(43.4)	0.56(14.2)	0.90(22.9)	0.38(9.7)	0.87(22.2)	0.81(20.6)
1/2	1/2	FHM-YZ8-NPT8-	1.93(49.0)	0.75(19.1)	0.90(22.9)	0.41(10.4)	0.07(22.2)	0.07(22.2)
1/2	3/4	FHM-YZ8-NPT12-	1.99(50.5)	0.75(19.1)	0.90(22.9)	0.41(10.4)	0.87(22.2)	1.06(27.0)
1/2	1	FHM-YZ8-NPT16-	2.25(57.2)	0.94(23.9)	0.90(22.9)	0.41(10.4)	0.87(22.2)	1.37(34.9)
5/8	1/4	FHM-YZ10-NPT4-	1.74(44.2)	0.56(14.2)	0.96(24.4)	0.28(7.1)	1.00(25.4)	0.94(23.8)
5/8	3/8	FHM-YZ10-NPT6-	1.74(44.2)	0.56(14.2)	0.96(24.4)	0.38(9.7)	1.00(25.4)	0.94(23.8)
5/8	1/2	FHM-YZ10-NPT8-	1.93(49.0)	0.75(19.1)	0.96(24.4)	0.47(11.9)	1.00(25.4)	0.94(23.8)
5/8	3/4	FHM-YZ10-NPT12-	1.99(50.5)	0.75(19.1)	0.96(24.4)	0.50(12.7)	1.00(25.4)	1.06(27.0)
3/4	3/8	FHM-YZ12-NPT6-	1.80(45.7)	0.56(14.2)	0.96(24.4)	0.41(10.4)	1.13(28.6)	1.06(27.0)
3/4	1/2	FHM-YZ12-NPT8-	1.99(50.5)	0.75(19.1)	0.96(24.4)	0.47(11.9)	1.13(28.6)	1.06(27.0)
3/4	3/4	FHM-YZ12-NPT12-	1.99(50.5)	0.75(19.1)	0.96(24.4)	0.62(15.7)	1.13(28.6)	1.06(27.0)
3/4	1	FHM-YZ12-NPT16-	2.25(57.2)	0.94(23.9)	0.96(24.4)	0.62(15.7)	1.13(28.6)	1.37(34.9)
7/8	1/2	FHM-YZ14-NPT8-	1.99(50.5)	0.75(19.1)	1.02(25.9)	0.47(11.9)	1.25(31.8)	1.19(30.2)
7/8	3/4	FHM-YZ14-NPT12-	1.99(50.5)	0.75(19.1)	1.02(25.9)	0.62(15.7)	1.25(31.8)	1.19(30.2)
7/8	1	FHM-YZ14-NPT16-	2.25(57.2)	0.94(23.9)	1.02(25.9)	0.72(18.3)	1.25(31.8)	1.37(34.9)
1	1/2	FHM-YZ16-NPT8-	2.26(57.4)	0.75(19.1)	1.23(31.2)	0.47(11.9)	1.50(38.1)	1.37(34.9)
1	3/4	FHM-YZ16-NPT12-	2.26(57.4)	0.75(19.1)	1.23(31.2)	0.62(15.7)	1.50(38.1)	1.37(34.9)
1	1	FHM-YZ16-NPT16-	2.45(62.2)	0.94(23.9)	1.23(31.2)	0.88(22.4)	1.50(38.1)	1.37(34.9)
1 1/8	1	FHM-YZ18-NPT16-	2.45(62.2)	0.94(23.9)	1.44(36.7)	0.88(22.4)	1.75(44.5)	1.63(41.3)
1 1/4	1	FHM-YZ20-NPT16-	3.04(77.2)	0.94(23.9)	1.62(41.1)	0.88(22.4)	1.87(47.6)	1.75(44.5)
1 1/4	1 1/4	FHM-YZ20-NPT20-	3.04(77.2)	0.94(23.9)	1.62(41.1)	1.09(27.7)	1.87(47.6)	1.75(44.5)
1 1/2	1 1/2	FHM-YZ24-NPT24-	3.50(88.9)	1.03(26.2)	1.97(50.0)	1.34(34.0)	2.25(57.2)	2.13(54.0)

# Размеры

## Щуцер с наружной резьбой

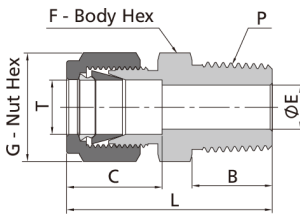

Размер E наименьший номинальный размер.

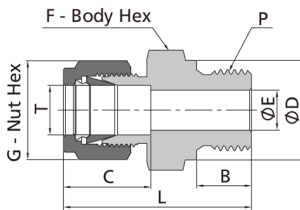

Размер E наименьший номинальный размер.

### Дюймовая трубка

### Коническая резьба ISO (RT)

Т-трубка O.D. (дюйм.)	Размер резьбы RT	Артикул	Размеры, дюймы (мм)					
			L	B	C	E	G	F
1/8	1/8	FHM-YZ2-RT2-	1.20 (30.5)	0.38 (9.7)	0.50 (12.7)	0.09 (2.3)	0.44 (11.1)	0.44 (11.1)
1/8	1/4	FHM-YZ2-RT4-	1.40 (35.6)	0.56 (14.2)	0.50 (12.7)	0.09 (2.3)	0.44 (11.1)	0.56 (14.3)
1/4	1/8	FHM-YZ4-RT2-	1.29 (32.8)	0.38 (9.7)	0.60 (15.2)	0.19 (4.8)	0.56 (14.3)	0.50 (12.7)
1/4	1/4	FHM-YZ4-RT4-	1.49 (37.8)	0.56 (14.2)	0.60 (15.2)	0.19 (4.8)	0.56 (14.3)	0.56 (14.3)
1/4	3/8	FHM-YZ4-RT6-	1.51 (38.4)	0.56 (14.2)	0.60 (15.2)	0.19 (4.8)	0.56 (14.3)	0.69 (17.5)
1/4	1/2	FHM-YZ4-RT8-	1.76 (44.7)	0.75 (19.1)	0.60 (15.2)	0.19 (4.8)	0.56 (14.3)	0.87 (22.2)
5/16	1/8	FHM-YZ5-RT2-	1.34 (34.0)	0.38 (9.7)	0.64 (16.3)	0.19 (4.8)	0.63 (15.9)	0.56 (14.3)
5/16	1/4	FHM-YZ5-RT4-	1.52 (38.6)	0.56 (14.2)	0.64 (16.3)	0.25 (6.4)	0.63 (15.9)	0.56 (14.3)
3/8	1/8	FHM-YZ6-RT2-	1.39 (35.3)	0.38 (9.7)	0.66 (16.8)	0.19 (4.8)	0.69 (17.5)	0.63 (15.9)
3/8	1/4	FHM-YZ6-RT4-	1.57 (39.9)	0.56 (14.2)	0.66 (16.8)	0.28 (7.1)	0.69 (17.5)	0.63 (15.9)
3/8	3/8	FHM-YZ6-RT6-	1.57 (39.9)	0.56 (14.2)	0.66 (16.8)	0.28 (7.1)	0.69 (17.5)	0.69 (17.5)
3/8	1/2	FHM-YZ6-RT8-	1.82 (46.2)	0.75 (19.1)	0.66 (16.8)	0.28 (7.1)	0.69 (17.5)	0.87 (22.2)
3/8	3/4	FHM-YZ6-RT12-	1.88 (47.8)	0.75 (19.1)	0.66 (16.8)	0.28 (7.1)	0.69 (17.5)	1.06 (27.0)
1/2	1/4	FHM-YZ8-RT4-	1.71 (43.4)	0.56 (14.2)	0.90 (22.9)	0.28 (7.1)	0.87 (22.2)	0.81 (20.6)
1/2	3/8	FHM-YZ8-RT6-	1.71 (43.4)	0.56 (14.2)	0.90 (22.9)	0.38 (9.7)	0.87 (22.2)	0.81 (20.6)
1/2	1/2	FHM-YZ8-RT8-	1.93 (49.0)	0.75 (19.1)	0.90 (22.9)	0.41 (10.4)	0.87 (22.2)	0.87 (22.2)
1/2	3/4	FHM-YZ8-RT12-	1.99 (50.5)	0.75 (19.1)	0.90 (22.9)	0.41 (10.4)	0.87 (22.2)	1.06 (27.0)
5/8	1/2	FHM-YZ10-RT8-	1.93 (49.0)	0.75 (19.1)	0.96 (24.4)	0.47 (11.9)	1.00 (25.4)	0.94 (23.8)
3/4	3/4	FHM-YZ12-RT12-	1.99 (50.5)	0.75 (19.1)	0.96 (24.4)	0.62 (15.7)	1.13 (28.6)	1.06 (27.0)
3/4	1	FHM-YZ12-RT16-	2.25 (57.2)	0.94 (23.9)	0.96 (24.4)	0.62 (15.7)	1.13 (28.6)	1.37 (34.9)
1	3/4	FHM-YZ16-RT12-	2.26 (57.4)	0.75 (19.1)	1.23 (31.2)	0.62 (15.7)	1.50 (38.1)	1.37 (34.9)
1	1	FHM-YZ16-RT16-	2.45 (62.2)	0.94 (23.9)	1.23 (31.2)	0.88 (22.4)	1.50 (38.1)	1.37 (34.9)

### Дюймовая трубка

### Цилиндрическая резьба ISO (RS)

Т-трубка O.D. (дюйм.)	Размер резьбы RS	Артикул	Размеры, дюймы. (мм)						
			L	B	C	E	G	F	D
1/8	1/8	FHM-YZ2-RS2-	1.18(30.0)	0.28(7.1)	0.50(12.7)	0.09(2.3)	0.44(11.1)	0.56(14.3)	0.54(13.7)
1/8	1/4	FHM-YZ2-RS4-	1.39(35.3)	0.44(11.2)	0.50(12.7)	0.09(2.3)	0.44(11.1)	0.75(19.1)	0.71(18.0)
1/8	3/8	FHM-YZ2-RS6-	1.43(36.3)	0.44(11.2)	0.50(12.7)	0.09(2.3)	0.44(11.1)	0.87(22.2)	0.86(21.8)
1/4	1/8	FHM-YZ4-RS2-	1.27(32.3)	0.28(7.1)	0.60(15.2)	0.16(4.0)	0.56(14.3)	0.56(14.3)	0.54(13.7)
1/4	1/4	FHM-YZ4-RS4-	1.48(37.6)	0.44(11.2)	0.60(15.2)	0.19(4.8)	0.56(14.3)	0.75(19.1)	0.71(18.0)
1/4	3/8	FHM-YZ4-RS6-	1.53(38.9)	0.44(11.2)	0.60(15.2)	0.19(4.8)	0.56(14.3)	0.87(22.2)	0.86(21.8)
1/4	1/2	FHM-YZ4-RS8-	1.76(44.7)	0.56(14.2)	0.60(15.2)	0.19(4.8)	0.56(14.3)	1.06(27.0)	1.02(25.9)
3/8	1/8	FHM-YZ6-RS2-	1.49(37.8)	0.28(7.1)	0.66(16.8)	0.16(4.0)	0.69(17.5)	0.63(15.9)	0.54(13.7)
3/8	1/4	FHM-YZ6-RS4-	1.54(39.1)	0.44(11.2)	0.66(16.8)	0.23(5.9)	0.69(17.5)	0.75(19.1)	0.71(18.0)
3/8	3/8	FHM-YZ6-RS6-	1.59(40.4)	0.44(11.2)	0.66(16.8)	0.28(7.1)	0.69(17.5)	0.87(22.2)	0.86(21.8)
3/8	1/2	FHM-YZ6-RS8-	1.82(46.2)	0.56(14.2)	0.66(16.8)	0.28(7.1)	0.69(17.5)	1.06(27.0)	1.02(25.9)
1/2	1/4	FHM-YZ8-RS4-	1.68(42.7)	0.44(11.2)	0.90(22.9)	0.23(5.9)	0.87(22.2)	0.81(20.6)	0.71(18.0)
1/2	3/8	FHM-YZ8-RS6-	1.70(43.2)	0.44(11.2)	0.90(22.9)	0.31(7.9)	0.87(22.2)	0.87(22.2)	0.86(21.8)
1/2	1/2	FHM-YZ8-RS8-	1.93(49.0)	0.56(14.2)	0.90(22.9)	0.41(10.4)	0.87(22.2)	1.06(27.0)	1.02(25.9)
3/4	1/2	FHM-YZ12-RS8	1.93(49.0)	0.56(14.2)	0.96(24.4)	0.47(11.9)	1.13(28.6)	1.06(27.0)	1.02(25.9)
3/4	3/4	FHM-YZ12-RS12-	2.08(52.9)	0.62(15.7)	0.96(24.4)	0.62(15.7)	1.13(28.6)	1.31(33.3)	1.26(32.0)
1	1/2	FHM-YZ16-RS8-	2.19(55.5)	0.56(14.2)	1.23(31.2)	0.47(11.9)	1.50(38.1)	1.37(34.9)	1.02(25.9)
1	3/4	FHM-YZ16-RS12-	2.27(57.7)	0.62(15.7)	1.23(31.2)	0.63(16.0)	1.50(38.1)	1.37(34.9)	1.26(32.0)
1	1	FHM-YZ16-RS16-	2.36(59.9)	0.72(18.3)	1.23(31.2)	0.78(19.8)	1.50(38.1)	1.63(41.3)	1.54(39.1)

## Штуцер с наружной резьбой

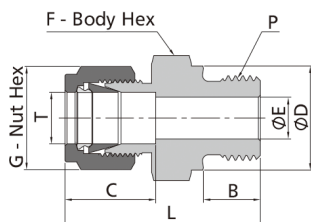

Размер E наименьший номинальный размер.

Дюймовая трубка			Коническая резьба ISO (RP)						
Т-трубка O.D. (дюйм.)	Размер резьбы RP	Артикул	Размеры, дюймы. (мм)						
			L	B	C	E	G	F	D
1/8	1/8	FHM-YZ2-RP2-	1.18 (30.0)	0.28 (7.1)	0.50 (12.7)	0.09 (2.3)	0.44 (11.1)	0.56 (14.3)	0.54 (13.8)
1/8	1/4	FHM-YZ2-RP4-	1.39 (35.3)	0.44 (11.2)	0.50 (12.7)	0.09 (2.3)	0.44 (11.1)	0.75 (19.1)	0.70 (17.8)
1/4	1/8	FHM-YZ4-RP2-	1.27 (32.3)	0.28 (7.1)	0.60 (15.2)	0.16 (4.1)	0.56 (14.3)	0.56 (14.3)	0.54 (13.8)
1/4	1/4	FHM-YZ4-RP4-	1.48 (37.6)	0.44 (11.2)	0.60 (15.2)	0.19 (4.8)	0.56 (14.3)	0.75 (19.1)	0.70 (17.8)
1/2	3/8	FHM-YZ8-RP6-	1.79 (45.5)	0.44 (11.2)	0.90 (22.9)	0.31 (7.9)	0.87 (22.2)	0.87 (22.2)	0.86 (21.8)
1/2	1/2	FHM-YZ8-RP8-	1.93 (49.0)	0.56 (14.2)	0.90 (22.9)	0.41 (10.4)	0.87 (22.2)	1.06 (27.0)	1.02 (25.9)
3/4	1/2	FHM-YZ12-RP8-	1.93 (49.0)	0.56 (14.2)	0.96 (24.4)	0.47 (11.9)	1.13 (28.6)	1.06 (27.0)	1.02 (25.9)
3/4	3/4	FHM-YZ12-RP12-	2.08 (52.9)	0.62 (15.7)	0.96 (24.4)	0.62 (15.7)	1.13 (28.6)	1.31 (33.3)	1.26 (32.0)
1	1	FHM-YZ16-RP16-	2.36 (59.9)	0.72 (18.3)	1.23 (31.2)	0.78 (19.8)	1.50 (38.1)	1.63 (41.3)	1.53 (38.8)

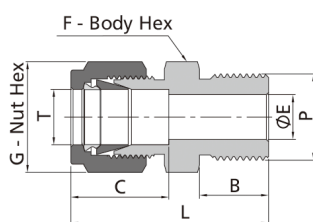

Размер E наименьший номинальный размер.

Дюймовая трубка			Цилиндрическая резьба ISO (BP)					
Т-трубка O.D. (дюйм.)	Размер резьбы RT	Артикул	Размеры, дюймы (мм)					
			L	B	C	E	G	F
1/4	3/8	FHM-YZ4-BP6-	1.51 (38.4)	0.56 (14.2)	0.60 (15.2)	0.19 (4.8)	0.56 (14.3)	0.69 (17.5)
3/8	3/8	FHM-YZ6-BP6--	1.57 (39.9)	0.56 (14.2)	0.66 (16.8)	0.28 (7.1)	0.69 (17.5)	0.69 (17.5)

# Размеры

## Штуцер с наружной резьбой

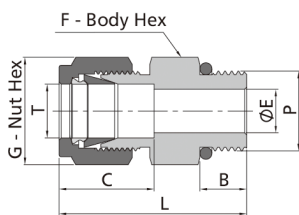

1. Размер E наименьший номинальный размер.

2. Адаптируется к втулке с прямой резьбой SAE J1926-1, ISO 11926-1 и MS 16142.

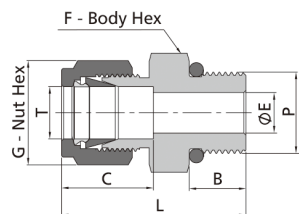

Размер E наименьший номинальный размер.

### Дюймовая трубка

### Прямая резьба SAE/MS (ST)

Т-трубка O.D. (дюйм.)	P-SAE Номинальный размер	P-SAE/MS Спецификация резьбы	Артикул	Размеры, дюймы. (мм)					
				L	B	C	E	G	F
1/16	2	5/16-24	FHM-YZ1-ST5-	0.92(23.4)	0.30(7.6)	0.34(8.6)	0.05(1.3)	0.31(7.9)	0.44(11.1)
1/8	2	5/16-24	FHM-YZ2-ST5-	1.18(30.0)	0.30(7.6)	0.50(12.7)	0.09(2.3)	0.44(11.1)	0.44(11.1)
1/8	4	7/16-20	FHM-YZ2-ST7-	1.24(31.5)	0.36(9.1)	0.50(12.7)	0.09(2.3)	0.44(11.1)	0.56(14.3)
1/8	6	9/16-18	FHM-YZ2-ST9-	1.31(33.3)	0.39(9.9)	0.50(12.7)	0.09(2.3)	0.44(11.1)	0.69(17.5)
3/16	3	3/8-24	FHM-YZ3-ST6-	1.20(30.5)	0.30(7.6)	0.54(13.7)	0.12(3.0)	0.50(12.7)	0.50(12.7)
1/4	2	5/16-24	FHM-YZ4-ST5-	1.27(32.3)	0.30(7.6)	0.60(15.2)	0.12(3.0)	0.56(14.3)	0.50(12.7)
1/4	4	7/16-20	FHM-YZ4-ST7-	1.34(34.0)	0.36(9.1)	0.60(15.2)	0.19(4.8)	0.56(14.3)	0.56(14.3)
1/4	6	9/16-18	FHM-YZ4-ST9-	1.40(35.6)	0.39(9.9)	0.60(15.2)	0.19(4.8)	0.56(14.3)	0.69(17.5)
1/4	8	3/4-16	FHM-YZ4-ST12-	1.48(37.6)	0.44(11.2)	0.60(15.2)	0.19(4.8)	0.56(14.3)	0.87(22.2)
1/4	10	7/8-14	FHM-YZ4-ST14-	1.60(40.6)	0.50(12.7)	0.60(15.2)	0.19(4.8)	0.56(14.3)	1.00(25.4)
5/16	5	1/2-20	FHM-YZ5-ST8-	1.37(34.8)	0.36(9.1)	0.64(16.3)	0.25(6.4)	0.63(15.9)	0.63(15.9)
3/8	4	7/16-20	FHM-YZ6-ST7-	1.40(35.6)	0.36(9.1)	0.66(16.8)	0.20(5.1)	0.69(17.5)	0.63(15.9)
3/8	6	9/16-18	FHM-YZ6-ST9-	1.46(37.1)	0.39(9.9)	0.66(16.8)	0.28(7.1)	0.69(17.5)	0.69(17.5)
3/8	8	3/4-16	FHM-YZ6-ST12-	1.54(39.1)	0.44(11.2)	0.66(16.8)	0.28(7.1)	0.69(17.5)	0.87(22.2)
3/8	10	7/8-14	FHM-YZ6-ST14-	1.66(42.2)	0.50(12.7)	0.66(16.8)	0.28(7.1)	0.69(17.5)	1.00(25.4)
1/2	6	9/16-18	FHM-YZ8-ST9-	1.54(39.1)	0.39(9.9)	0.90(22.9)	0.28(7.1)	0.87(22.2)	0.81(20.6)
1/2	8	3/4-16	FHM-YZ8-ST12-	1.65(41.9)	0.44(11.2)	0.90(22.9)	0.41(10.4)	0.87(22.2)	0.87(22.2)
1/2	10	7/8-14	FHM-YZ8-ST14-	1.77(45.0)	0.50(12.7)	0.90(22.9)	0.41(10.4)	0.87(22.2)	1.00(25.4)
1/2	12	1 1/16-12	FHM-YZ8-ST17-	1.93(49.0)	0.59(15.0)	0.90(22.9)	0.41(10.4)	0.87(22.2)	1.25(31.8)
5/8	8	3/4-16	FHM-YZ10-ST12-	1.65(41.9)	0.44(11.2)	0.96(24.4)	0.42(10.7)	1.00(25.4)	0.94(23.8)
5/8	10	7/8-14	FHM-YZ10-ST14-	1.78(45.2)	0.50(12.7)	0.96(24.4)	0.50(12.7)	1.00(25.4)	1.00(25.4)
3/4	8	3/4-16	FHM-YZ12-ST12-	1.81(46.0)	0.44(11.2)	0.96(24.4)	0.42(10.7)	1.13(28.6)	1.06(27.0)
3/4	12	1 1/16-12	FHM-YZ12-ST17-	1.93(49.0)	0.59(15.0)	0.96(24.4)	0.62(15.7)	1.13(28.6)	1.25(31.8)
3/4	16	1 5/16-12	FHM-YZ12-ST21-	1.96(49.8)	0.59(15.0)	0.96(24.4)	0.63(16.0)	1.13(28.6)	1.50(38.1)
7/8	14	1 3/16-12	FHM-YZ14-ST19-	1.93(49.0)	0.59(15.0)	1.02(25.9)	0.72(18.3)	1.25(31.8)	1.37(34.9)
1	12	1 1/16-12	FHM-YZ16-ST17-	2.10(53.3)	0.59(15.0)	1.23(31.2)	0.66(16.8)	1.50(38.1)	1.37(34.9)
1	16	1 5/16-12	FHM-YZ16-ST21-	2.14(54.4)	0.59(15.0)	1.23(31.2)	0.88(22.4)	1.50(38.1)	1.50(38.1)
1 1/4	20	1 5/8-12	FHM-YZ20-ST26-	2.69(68.3)	0.59(15.0)	1.62(41.1)	1.09(27.7)	1.87(47.6)	1.87(47.6)
1 1/2	24	1 7/8-12	FHM-YZ24-ST30-	3.06(77.7)	0.59(15.0)	1.97(50.0)	1.34(34.0)	2.25(57.2)	2.13(54.0)

### Дюймовая трубка

### Прямая резьба SAE/MS (ST)

Т-трубка O.D. (дюйм.)	P-SAE Номинальный размер	P-SAE/MS Спецификация резьбы	Артикул	Размеры, дюймы. (мм)					
				L	B	C	E	G	F
1/4	4	7/16-20	FHM-YZ4-ST7-	2.26(57.4)	0.36(9.1)	0.60(15.2)	0.19(4.8)	0.56(14.3)	0.56(14.3)
1/2	8	3/4-16	FHM-YZ8-ST12-	3.01(76.5)	0.44(11.2)	0.90(22.9)	0.41(10.4)	0.87(22.2)	0.87(22.2)



## Штуцер с наружной резьбой

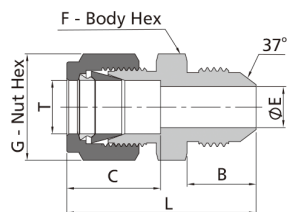

Размер E наименьший номинальный размер.

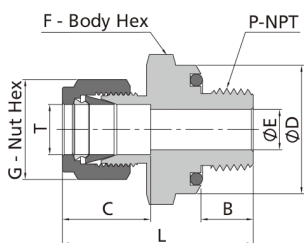

Размер E наименьший номинальный размер.

Дюймовая трубка			Резьба с уплотнительным конусом 37 (AN)					
Т-трубка O.D. (дюйм.)	Размер резьбы	Артикул	Размеры, дюймы. (мм)					
			L	B	C	E	G	F
1/16	1/8	FHM-YZ1-AN2-	1.07(27.2)	0.45(11.4)	0.34(8.6)	0.05(1.3)	0.31(7.9)	0.44(11.1)
1/8	1/8	FHM-YZ2-AN2-	1.27(32.3)	0.45(11.4)	0.50(12.7)	0.06(1.5)	0.44(11.1)	0.44(11.1)
1/8	1/4	FHM-YZ2-AN4-	1.38(35.1)	0.55(14.0)	0.50(12.7)	0.09(2.3)	0.44(11.1)	0.50(12.7)
3/16	3/16	FHM-YZ3-AN3-	1.32(33.5)	0.48(12.2)	0.54(13.7)	0.12(3.0)	0.50(12.7)	0.44(11.1)
1/4	1/4	FHM-YZ4-AN4-	1.48(37.6)	0.55(14.0)	0.60(15.2)	0.17(4.3)	0.56(14.3)	0.50(12.7)
5/16	5/16	FHM-YZ5-AN5-	1.51(38.4)	0.55(14.0)	0.64(16.2)	0.23(5.8)	0.63(15.9)	0.56(14.3)
3/8	1/4	FHM-YZ6-AN4-	1.56(39.6)	0.55(14.0)	0.66(16.8)	0.17(4.3)	0.69(17.5)	0.63(15.9)
3/8	3/8	FHM-YZ6-AN6-	1.56(39.6)	0.56(14.1)	0.66(16.8)	0.28(7.1)	0.69(17.5)	0.63(15.9)
1/2	1/2	FHM-YZ8-AN8-	1.81(46.0)	0.66(16.7)	0.90(22.8)	0.39(9.9)	0.87(22.2)	0.81(20.6)
5/8	5/8	FHM-YZ10-AN10-	1.93(49.0)	0.76(19.3)	0.96(24.5)	0.48(12.3)	1.00(25.4)	0.94(23.8)
3/4	3/4	FHM-YZ12-AN12-	2.10(53.3)	0.86(21.9)	0.96(24.4)	0.61(15.5)	1.13(28.6)	1.13(28.6)
1	1	FHM-YZ16-AN16-	2.42(61.5)	0.91(23.1)	1.23(31.2)	0.84(21.3)	1.50(38.1)	1.37(34.9)

Дюймовая трубка			Резьба NPT с кольцом						
Т-трубка O.D. (дюйм.)	Размер резьбы	Артикул	Dimensions, in. (mm)						
			L	B	C	E	G	F	D
1/8	1/8	FHM-YZ2-ON2-	1.29(32.8)	0.28(7.1)	0.34(8.6)	0.09(2.3)	0.47(11.9)	0.75(19.1)	0.74(18.8)
1/4	1/8	FHM-YZ4-ON2-	1.38(35.1)	0.28(7.1)	0.60(15.2)	0.19(4.8)	0.56(14.3)	0.75(19.1)	0.74(18.8)
1/4	1/4	FHM-YZ4-ON4-	1.51(38.4)	0.38(9.7)	0.60(15.2)	0.19(4.8)	0.56(14.3)	0.94(23.8)	0.93(23.6)
3/8	1/4	FHM-YZ6-ON4-	1.57(39.9)	0.38(9.7)	0.66(16.8)	0.28(7.1)	0.69(17.5)	0.94(23.8)	0.93(23.6)
3/8	3/8	FHM-YZ6-ON6-	1.63(41.4)	0.41(10.4)	0.66(16.8)	0.28(7.1)	0.69(17.5)	1.13(28.6)	1.12(28.4)
3/8	1/2	FHM-YZ6-ON8-	1.85(47.0)	0.53(13.5)	0.66(16.8)	0.28(7.1)	0.69(17.5)	1.31(33.3)	1.30(33.0)
1/2	1/2	FHM-YZ8-ON8-	1.96(49.8)	0.53(13.5)	0.90(22.9)	0.41(10.4)	0.87(22.2)	1.31(33.3)	1.30(33.0)

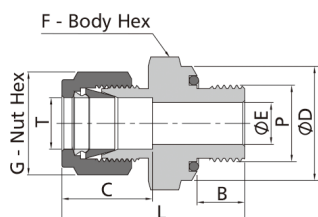

Размер E наименьший номинальный размер.

Дюймовая трубка			Прямая резьба SAE/MS (OST)								
Т-трубка O.D. (дюйм.)	P-SAE Номин размер	P-SAE/MS Спецификация резьбы	Артикул	Размеры, дюймы. (мм)							
				L	B	C	E	G	F	D	
1/16	2	5/16-24	FHM-YZ1-OST5-	1.05(26.7)	0.34(8.6)	0.34(8.6)	0.05(1.3)	0.31(7.9)	0.56(14.3)	0.55(14.0)	
1/8	2	5/16-24	FHM-YZ2-OST5-	1.29(32.8)	0.34(8.6)	0.50(12.7)	0.09(2.3)	0.44(11.1)	0.56(14.3)	0.55(14.0)	
3/16	3	3/8-24	FHM-YZ3-OST6-	1.35(34.3)	0.38(9.7)	0.54(13.7)	0.12(3.0)	0.50(12.7)	0.63(15.9)	0.62(15.7)	
1/4	4	7/16-20	FHM-YZ4-OST7-	1.51(38.4)	0.41(10.4)	0.60(15.2)	0.19(4.8)	0.56(14.3)	0.75(19.1)	0.74(18.8)	
5/16	5	1/2-20	FHM-YZ5-OST8-	1.60(40.6)	0.44(11.2)	0.64(16.3)	0.25(6.4)	0.63(15.9)	0.87(22.2)	0.86(21.8)	
3/8	6	9/16-18	FHM-YZ 6-OST9-	1.67(42.4)	0.47(11.9)	0.66(16.8)	0.28(7.1)	0.69(17.5)	0.94(23.8)	0.93(23.6)	
1/2	8	3/4-16	FHM-YZ8-OST12-	1.81(46.0)	0.47(11.9)	0.90(22.9)	0.41(10.4)	0.87(22.2)	1.13(28.6)	1.12(28.4)	
3/4	12	1 1/16-12	FHM-YZ12-OST17-	2.06(52.3)	0.56(14.2)	0.96(24.4)	0.62(15.7)	1.13(28.6)	1.50(38.1)	1.49(37.8)	
1	16	1 5/16-12	FHM-YZ16-OST21-	2.29(58.2)	0.56(14.2)	1.23(31.2)	0.88(22.4)	1.50(38.1)	1.75(44.5)	1.74(44.2)	

# Размеры

## Штуцер с наружной резьбой

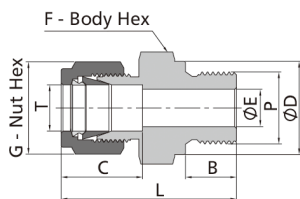

Размер E наименьший номинальный размер.

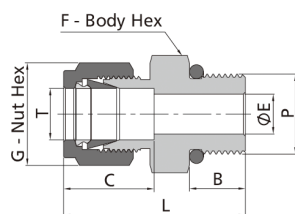

1. Размер E наименьший номинальный размер.

2. Прямая резьба согласно ISO 6149-

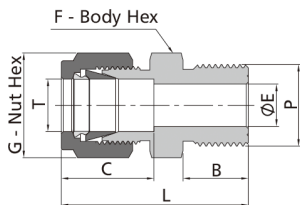

Размер E наименьший номинальный размер.

### Дюймовая трубка

### Метрическая резьба (MRS)

Т-трубка O.D. (дюйм.)	P-Метрический размер резьбы	Артикул	Размеры, дюймы. (мм)						
			L	B	C	E	G	F	D
1/8	M14 × 1.5	FHM-YZ2-MRS14-	1.44(36.7)	0.47(12.0)	0.50(12.7)	0.09(2.3)	0.44(11.1)	0.75(19.1)	0.75(19.0)
1/8	M16 × 1.5	FHM-YZ2-MRS16-	1.48(37.5)	0.47(12.0)	0.50(12.7)	0.09(2.3)	0.44(11.1)	0.87(22.2)	0.83(21.0)
1/8	M18 × 1.5	FHM-YZ2-MRS18-	1.52(38.5)	0.47(12.0)	0.50(12.7)	0.09(2.3)	0.44(11.1)	0.94(23.8)	0.91(23.0)
1/8	M20 × 1.5	FHM-YZ2-MRS20-	1.62(41.1)	0.55(14.0)	0.50(12.7)	0.09(2.3)	0.44(11.1)	1.00(25.4)	0.98(25.0)
1/4	M14 × 1.5	FHM-YZ4-MRS14-	1.50(38.0)	0.47(12.0)	0.60(15.2)	0.19(4.8)	0.56(14.3)	0.75(19.1)	0.75(19.0)
1/4	M16 × 1.5	FHM-YZ4-MRS16-	1.57(39.9)	0.47(12.0)	0.60(15.2)	0.19(4.8)	0.56(14.3)	0.87(22.2)	0.83(21.0)
1/4	M18 × 1.5	FHM-YZ4-MRS18-	1.61(40.8)	0.47(12.0)	0.60(15.2)	0.19(4.8)	0.56(14.3)	0.94(23.8)	0.91(23.0)
1/4	M20 × 1.5	FHM-YZ4-MRS20-	1.72(43.6)	0.55(14.0)	0.60(15.2)	0.19(4.8)	0.56(14.3)	1.00(25.4)	0.98(25.0)
3/8	M14 × 1.5	FHM-YZ6-MRS14-	1.63(41.3)	0.47(12.0)	0.66(16.8)	0.28(7.1)	0.69(17.5)	0.75(19.1)	0.75(19.0)
3/8	M16 × 1.5	FHM-YZ6-MRS16-	1.63(41.3)	0.47(12.0)	0.66(16.8)	0.28(7.1)	0.69(17.5)	0.87(22.2)	0.83(21.0)
3/8	M18 × 1.5	FHM-YZ6-MRS18-	1.65(41.8)	0.47(12.0)	0.66(16.8)	0.28(7.1)	0.69(17.5)	0.94(23.8)	0.91(23.0)
3/8	M20 × 1.5	FHM-YZ6-MRS20-	1.78(45.1)	0.55(14.0)	0.66(16.8)	0.28(7.1)	0.69(17.5)	1.00(25.4)	0.98(25.0)
1/2	M16 × 1.5	FHM-YZ8-MRS16-	1.73(44.0)	0.47(12.0)	0.90(22.8)	0.35(9.0)	0.87(22.2)	0.87(22.2)	0.83(21.0)
1/2	M18 × 1.5	FHM-YZ8-MRS18-	1.73(44.0)	0.47(12.0)	0.90(22.9)	0.39(10.0)	0.87(22.2)	0.94(23.8)	0.91(23.0)
1/2	M20 × 1.5	FHM-YZ8-MRS20-	1.89(47.9)	0.55(14.0)	0.90(22.9)	0.41(10.4)	0.87(22.2)	1.00(25.4)	0.98(25.0)
1/2	M22 × 1.5	FHM-YZ8-MRS22-	1.91(48.5)	0.55(14.0)	0.90(22.9)	0.41(10.4)	0.87(22.2)	1.06(27.0)	1.06(27.0)

### Дюймовая трубка

### Метрическая резьба (MST)

Т-трубка O.D. (дюйм.)	P-Метрический размер резьбы	Артикул	Размеры, дюймы. (мм)					
			L	B	C	E	G	F
1/4	M14X1.5	FHM-YZ4-MST14-	1.39(35.2)	0.43(11.0)	0.60(15.2)	0.19(4.8)	0.56(14.3)	0.75(19.1)
3/8	M14X1.5	FHM-YZ6-MST14-	1.44(36.7)	0.43(11.0)	0.66(16.8)	0.28(7.1)	0.69(17.5)	0.75(19.1)
3/8	M20X1.5	FHM-YZ6-MST20-	1.62(41.2)	0.55(14.0)	0.66(16.8)	0.28(7.1)	0.69(17.5)	1.06(27.0)
1/2	M14X1.5	FHM-YZ8-MST14-	1.58(40.2)	0.43(11.0)	0.90(22.9)	0.30(7.5)	0.87(22.2)	0.81(20.6)
1/2	M20X1.5	FHM-YZ8-MST20-	1.73(44.0)	0.55(14.0)	0.90(22.9)	0.41(10.4)	0.87(22.2)	1.06(27.0)

### Дюймовая трубка

### Метрическая резьба (MS)

Т-трубка O.D. (дюйм.)	P-Метрический размер резьбы	Артикул	Размеры, дюймы. (мм)					
			L	B	C	E	G	F
1/16	M5 × 0.8	FHM-YZ1-MS5-	0.86(21.8)	0.31(8.0)	0.34(8.6)	0.05(1.3)	0.31(7.9)	0.31(7.9)
1/8	M14 × 1.5	FHM-YZ2-MS14-	1.37(34.8)	0.51(13.0)	0.50(12.7)	0.09(2.3)	0.44(11.1)	0.63(15.9)
1/8	M16 × 1.5	FHM-YZ2-MS16-	1.41(35.8)	0.55(14.0)	0.50(12.7)	0.09(2.3)	0.44(11.1)	0.69(17.5)
1/8	M18 × 1.5	FHM-YZ2-MS16-	1.46(37.2)	0.59(15.0)	0.50(12.7)	0.09(2.3)	0.44(11.1)	0.75(19.1)
1/8	M20 × 1.5	FHM-YZ2-MS20-	1.50(38.1)	0.63(16.0)	0.50(12.7)	0.09(2.3)	0.44(11.1)	0.87(22.2)
1/4	M14 × 1.5	FHM-YZ4-MS14-	1.45(36.9)	0.51(13.0)	0.60(15.2)	0.19(4.8)	0.56(14.3)	0.63(15.9)
1/4	M16 × 1.5	FHM-YZ4-MS16-	1.50(38.1)	0.55(14.0)	0.60(15.2)	0.19(4.8)	0.56(14.3)	0.69(17.5)
1/4	M18 × 1.5	FHM-YZ4-MS16-	1.56(39.5)	0.59(15.0)	0.60(15.2)	0.19(4.8)	0.56(14.3)	0.75(19.1)
1/4	M20 × 1.5	FHM-YZ4-MS20-	1.60(40.7)	0.63(16.0)	0.60(15.2)	0.19(4.8)	0.56(14.3)	0.87(22.2)
3/8	M10 × 1.0	FHM-YZ6-MS10-	1.43(36.4)	0.43(11.0)	0.66(16.8)	0.19(4.8)	0.69(17.5)	0.63(15.9)
3/8	M14 × 1.5	FHM-YZ6-MS14-	1.55(39.3)	0.51(13.0)	0.66(16.8)	0.28(7.1)	0.69(17.5)	0.63(15.9)
3/8	M16 × 1.5	FHM-YZ6-MS16-	1.56(39.7)	0.55(14.0)	0.66(16.8)	0.28(7.1)	0.69(17.5)	0.69(17.5)
3/8	M18 × 1.5	FHM-YZ6-MS18-	1.63(41.5)	0.59(15.0)	0.66(16.8)	0.28(7.1)	0.69(17.5)	0.75(19.1)
3/8	M20 × 1.5	FHM-YZ6-MS20-	1.67(42.3)	0.63(16.0)	0.66(16.8)	0.28(7.1)	0.69(17.5)	0.87(22.2)
1/2	M16 × 1.5	FHM-YZ8-MS16-	1.70(43.2)	0.55(14.0)	0.90(22.9)	0.33(8.4)	0.87(22.2)	0.81(20.6)
1/2	M18 × 1.5	FHM-YZ8-MS18-	1.72(43.7)	0.59(15.0)	0.90(22.9)	0.38(9.6)	0.87(22.2)	0.81(20.6)
1/2	M20 × 1.5	FHM-YZ8-MS20-	1.77(44.9)	0.63(16.0)	0.90(22.9)	0.41(10.4)	0.87(22.2)	0.87(22.2)
1/2	M22 × 1.5	FHM-YZ8-MS22-	1.85(47.0)	0.67(17.0)	0.90(22.9)	0.41(10.4)	0.87(22.2)	0.94(23.8)

## Штуцер с наружной резьбой

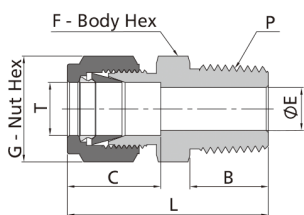

Размер E наименьший номинальный размер

### Метрическая трубка Резьба NPT

Т-трубка O.D. (мм.)	Размер резьбы NPT	Артикул	Размеры, дюймы. (мм)						
			L	B	C	E	G	F	
2	1/8	FHM-GZ2-NPT2-	30.5(1.20)	9.7(0.38)	1	2.9(0.51)	1.7(0.07)	12.0(0.47)	12.0(0.47)
3	1/8	FHM-GZ3-NPT2-	30.5(1.20)	9.7(0.38)		12.9(0.51)	2.4(0.09)	12.0(0.47)	12.0(0.47)
3	1/4	FHM-GZ3-NPT4-	35.6(1.40)	14.2(0.56)		12.9(0.51)	2.4(0.09)	12.0(0.47)	14.0(0.55)
4	1/8	FHM-GZ4-NPT2-	31.2(1.23)	9.7(0.38)		13.7(0.54)	2.4(0.09)	12.0(0.47)	12.0(0.47)
4	1/4	FHM-GZ4-NPT4-	36.3(1.43)	14.2(0.56)		13.7(0.54)	2.4(0.09)	12.0(0.47)	14.0(0.55)
6	1/8	FHM-GZ6-NPT2-	32.8(1.29)	9.7(0.38)		15.3(0.60)	4.8(0.19)	14.0(0.55)	14.0(0.55)
6	1/4	FHM-GZ6-NPT4-	37.9(1.49)	14.2(0.56)		15.3(0.60)	4.8(0.19)	14.0(0.55)	14.0(0.55)
6	3/8	FHM-GZ6-NPT6-	38.4(1.51)	14.2(0.56)		15.3(0.60)	4.8(0.19)	14.0(0.55)	18.0(0.71)
6	1/2	FHM-GZ6-NPT8-	44.7(1.76)	19.1(0.75)		15.3(0.60)	4.8(0.19)	14.0(0.55)	22.0(0.87)
8	1/8	FHM-GZ8-NPT2-	34.2(1.35)	9.7(0.38)		16.2(0.64)	4.8(0.19)	16.0(0.63)	15.0(0.59)
8	1/4	FHM-GZ8-NPT4-	38.7(1.52)	14.2(0.56)		16.2(0.64)	6.4(0.25)	16.0(0.63)	15.0(0.59)
8	3/8	FHM-GZ8-NPT6-	39.3(1.55)	14.2(0.56)		16.2(0.64)	6.4(0.25)	16.0(0.63)	18.0(0.71)
8	1/2	FHM-GZ8-NPT8-	45.6(1.80)	19.1(0.75)		16.2(0.64)	6.4(0.25)	16.0(0.63)	22.0(0.87)
10	1/8	FHM-GZ10-NPT2-	36.3(1.43)	9.7(0.38)		17.2(0.68)	4.8(0.19)	19.0(0.75)	18.0(0.71)
10	1/4	FHM-GZ10-NPT4-	40.9(1.61)	14.2(0.56)		17.2(0.68)	7.1(0.28)	19.0(0.75)	18.0(0.71)
10	3/8	FHM-GZ10-NPT6-	40.9(1.61)	14.2(0.56)		17.2(0.68)	7.9(0.31)	19.0(0.75)	18.0(0.71)
10	1/2	FHM-GZ10-NPT8-	46.5(1.83)	19.1(0.75)		17.2(0.68)	7.9(0.31)	19.0(0.75)	22.0(0.87)
10	3/4	FHM-GZ10-NPT12-	48.0(1.89)	19.1(0.75)		17.2(0.68)	7.9(0.31)	19.0(0.75)	27.0(1.06)
10	1	FHM-GZ10-NPT16-	54.6(2.15)	23.9(0.94)		17.2(0.68)	7.9(0.31)	19.0(0.75)	35.0(1.38)
12	1/8	FHM-GZ12-NPT2-	38.8(1.53)	9.7(0.38)		22.8(0.90)	4.8(0.19)	22.0(0.87)	22.0(0.87)
12	1/4	FHM-GZ12-NPT4-	43.4(1.71)	14.2(0.56)		22.8(0.90)	7.1(0.28)	22.0(0.87)	22.0(0.87)
12	3/8	FHM-GZ12-NPT6-	43.4(1.71)	14.2(0.56)		22.8(0.90)	9.5(0.37)	22.0(0.87)	22.0(0.87)
12	1/2	FHM-GZ12-NPT8-	49.0(1.93)	19.1(0.75)		22.8(0.90)	9.5(0.37)	22.0(0.87)	22.0(0.87)
12	3/4	FHM-GZ12-NPT12-	49.1(1.93)	19.1(0.75)		22.8(0.90)	9.5(0.37)	22.0(0.87)	27.0(1.06)
14	1/8	FHM-GZ14-NPT2-	39.9(1.57)	9.7(0.38)		24.4(0.96)	4.8(0.19)	25.0(0.98)	24.0(0.94)
14	1/4	FHM-GZ14-NPT4-	44.1(1.74)	14.2(0.56)		24.4(0.96)	7.1(0.28)	25.0(0.98)	24.0(0.94)
14	3/8	FHM-GZ14-NPT6-	44.1(1.74)	14.2(0.56)		24.4(0.96)	9.5(0.37)	25.0(0.98)	24.0(0.94)
14	1/2	FHM-GZ14-NPT8-	49.0(1.93)	19.1(0.75)		24.4(0.96)	11.1(0.44)	25.0(0.98)	24.0(0.94)
14	3/4	FHM-GZ14-NPT12-	49.1(1.93)	19.1(0.75)		24.4(0.96)	11.1(0.44)	25.0(0.98)	27.0(1.06)
15	1/2	FHM-GZ15-NPT8-	49.0(1.93)	19.1(0.75)		24.4(0.96)	11.9(0.47)	25.0(0.98)	24.0(0.94)
15	3/4	FHM-GZ15-NPT12-	50.5(1.99)	19.1(0.75)		24.4(0.96)	11.9(0.47)	25.0(0.98)	27.0(1.06)
15	1	FHM-GZ15-NPT16-	57.1(2.25)	23.9(0.94)		24.4(0.96)	11.9(0.47)	25.0(0.98)	35.0(1.38)
16	1/4	FHM-GZ16-NPT4-	44.1(1.74)	14.2(0.56)		24.4(0.96)	7.1(0.28)	25.0(0.98)	24.0(0.94)
16	3/8	FHM-GZ16-NPT6-	44.1(1.74)	14.2(0.56)		24.4(0.96)	9.5(0.37)	25.0(0.98)	24.0(0.94)
16	1/2	FHM-GZ16-NPT8-	49.0(1.93)	19.1(0.75)		24.4(0.96)	11.9(0.47)	25.0(0.98)	24.0(0.94)
16	3/4	FHM-GZ16-NPT12-	50.5(1.99)	19.1(0.75)		24.4(0.96)	12.7(0.5)	25.0(0.98)	27.0(1.06)
18	3/8	FHM-GZ18-NPT6-	45.6(1.80)	14.2(0.56)		24.4(0.96)	9.5(0.37)	30.0(1.18)	27.0(1.06)
18	1/2	FHM-GZ18-NPT8-	50.5(1.99)	19.1(0.75)		24.4(0.96)	11.9(0.47)	30.0(1.18)	27.0(1.06)
18	3/4	FHM-GZ18-NPT12-	50.5(1.99)	19.1(0.75)		24.4(0.96)	15.1(0.59)	30.0(1.18)	27.0(1.06)
20	1/2	FHM-GZ20-NPT8-	52.3(2.06)	19.1(0.75)		26.0(1.02)	11.9(0.47)	32.0(1.26)	30.0(1.18)
20	3/4	FHM-GZ20-NPT12-	52.3(2.06)	19.1(0.75)		26.0(1.02)	15.9(0.63)	32.0(1.26)	30.0(1.18)
20	1	FHM-GZ20-NPT16-	57.1(2.25)	23.9(0.94)		26.0(1.02)	15.9(0.63)	32.0(1.26)	35.0(1.38)
22	1/2	FHM-GZ22-NPT8-	52.3(2.06)	19.1(0.75)		26.0(1.02)	11.9(0.47)	32.0(1.26)	30.0(1.18)
22	3/4	FHM-GZ22-NPT12-	52.3(2.06)	19.1(0.75)		26.0(1.02)	15.9(0.63)	32.0(1.26)	30.0(1.18)
22	1	FHM-GZ22-NPT16-	57.1(2.25)	23.9(0.94)		26.0(1.02)	18.3(0.72)	32.0(1.26)	35.0(1.38)
25	1/2	FHM-GZ25-NPT8-	57.5(2.26)	19.1(0.75)		31.3(1.23)	11.9(0.47)	38.0(1.50)	35.0(1.38)
25	3/4	FHM-GZ25-NPT12-	57.5(2.26)	19.1(0.75)		31.3(1.23)	15.9(0.63)	38.0(1.50)	35.0(1.38)
25	1	FHM-GZ25-NPT16-	62.3(2.45)	23.9(0.94)		31.3(1.23)	21.8(0.86)	38.0(1.50)	35.0(1.38)
28	1	FHM-GZ28-NPT16-	72.4(2.85)	23.9(0.94)		36.6(1.44)	21.8(0.86)	46.0(1.81)	41.0(1.61)
28	1 1/4	FHM-GZ28-NPT20-	73.1(2.88)	23.9(0.94)		36.6(1.44)	21.8(0.86)	46.0(1.81)	46.0(1.81)
30	1 1/4	FHM-GZ30-NPT20-	77.2(3.04)	23.9(0.94)		39.6(1.56)	26.2(1.03)	50.0(1.97)	46.0(1.81)
32	1 1/4	FHM-GZ32-NPT20-	79.6(3.13)	23.9(0.94)		42.0(1.65)	28.6(1.13)	50.0(1.97)	46.0(1.81)
38	1 1/2	FHM-GZ38-NPT24-	91.6(3.61)	26.2(1.03)		49.4(1.94)	33.7(1.33)	60.0(2.36)	55.0(2.17)

# Размеры

## Штуцер с наружной резьбой

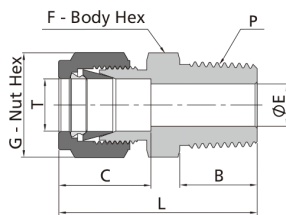

Размер E наименьший номинальный размер.

### Метрическая трубка

### Коническая резьба ISO (RT)

Т-трубка O.D. (мм.)	Размер резьбы RT	Артикул	Размеры, дюймы. (мм)					
			L	B	C	E	G	F
2	1/8	FHM-GZ2-RT2-	30.5(1.20)	9.7(0.38)	12.9(0.51)	1.7(0.07)	12.0(0.47)	12.0(0.47)
3	1/8	FHM-GZ3-RT2-	30.5(1.20)	9.7(0.38)	12.9(0.51)	2.4(0.09)	12.0(0.47)	12.0(0.47)
3	1/4	FHM-GZ3-RT4-	35.6(1.40)	14.2(0.56)	12.9(0.51)	2.4(0.09)	12.0(0.47)	14.0(0.55)
4	1/8	FHM-GZ4-RT2-	31.2(1.23)	9.7(0.38)	13.7(0.54)	2.4(0.09)	12.0(0.47)	12.0(0.47)
4	1/4	FHM-GZ4-RT4-	36.3(1.43)	14.2(0.56)	13.7(0.54)	2.4(0.09)	12.0(0.47)	14.0(0.55)
6	1/8	FHM-GZ6-RT2-	32.8(1.29)	9.7(0.38)	15.3(0.60)	4.8(0.19)	14.0(0.55)	14.0(0.55)
6	1/4	FHM-GZ6-RT4-	37.9(1.49)	14.2(0.56)	15.3(0.60)	4.8(0.19)	14.0(0.55)	14.0(0.55)
6	3/8	FHM-GZ6-RT6-	38.4(1.51)	14.2(0.56)	15.3(0.60)	4.8(0.19)	14.0(0.55)	18.0(0.71)
6	1/2	FHM-GZ6-RT8-	44.7(1.76)	19.1(0.75)	15.3(0.60)	4.8(0.19)	14.0(0.55)	22.0(0.87)
8	1/8	FHM-GZ8-RT2-	34.2(1.35)	9.7(0.38)	16.2(0.64)	4.8(0.19)	16.0(0.63)	15.0(0.59)
8	1/4	FHM-GZ8-RT4-	38.7(1.52)	14.2(0.56)	16.2(0.64)	6.4(0.25)	16.0(0.63)	15.0(0.59)
8	3/8	FHM-GZ8-RT6-	39.2(1.54)	14.2(0.56)	16.2(0.64)	6.4(0.25)	16.0(0.63)	18.0(0.71)
8	1/2	FHM-GZ8-RT8-	45.6(1.80)	19.1(0.75)	16.2(0.64)	6.4(0.25)	16.0(0.63)	22.0(0.87)
10	1/8	FHM-GZ10-RT2-	36.3(1.43)	9.7(0.38)	17.2(0.68)	4.8(0.19)	19.0(0.75)	18.0(0.71)
10	1/4	FHM-GZ10-RT4-	40.9(1.61)	14.2(0.56)	17.2(0.68)	7.1(0.28)	19.0(0.75)	18.0(0.71)
10	3/8	FHM-GZ10-RT6-	40.9(1.61)	14.2(0.56)	17.2(0.68)	7.9(0.31)	19.0(0.75)	18.0(0.71)
10	1/2	FHM-GZ10-RT8-	46.5(1.83)	19.1(0.75)	17.2(0.68)	7.9(0.31)	19.0(0.75)	22.0(0.87)
10	3/4	FHM-GZ10-RT12-	48.0(1.89)	19.1(0.75)	17.2(0.68)	7.9(0.31)	19.0(0.75)	27.0(1.06)
12	1/8	FHM-GZ12-RT2-	38.9(1.53)	9.7(0.38)	22.8(0.90)	4.8(0.19)	22.0(0.87)	22.0(0.87)
12	1/4	FHM-GZ12-RT4-	43.4(1.71)	14.2(0.56)	22.8(0.90)	7.1(0.28)	22.0(0.87)	22.0(0.87)
12	3/8	FHM-GZ12-RT6-	43.4(1.71)	14.2(0.56)	22.8(0.90)	9.5(0.37)	22.0(0.87)	22.0(0.87)
12	1/2	FHM-GZ12-RT8-	49.0(1.93)	19.1(0.75)	22.8(0.90)	9.5(0.37)	22.0(0.87)	22.0(0.87)
12	3/4	FHM-GZ12-RT12-	50.5(1.99)	19.1(0.75)	22.8(0.90)	9.5(0.37)	22.0(0.87)	27.0(1.06)
14	1/8	FHM-GZ14-RT2-	39.9(1.57)	9.7(0.38)	24.4(0.96)	4.8(0.19)	25.0(0.98)	24.0(0.94)
14	1/4	FHM-GZ14-RT4-	44.1(1.74)	14.2(0.56)	24.4(0.96)	7.1(0.28)	25.0(0.98)	24.0(0.94)
14	3/8	FHM-GZ14-RT6-	44.1(1.74)	14.2(0.56)	24.4(0.96)	9.5(0.37)	25.0(0.98)	24.0(0.94)
14	1/2	FHM-GZ14-RT8-	49.0(1.93)	19.1(0.75)	24.4(0.96)	11.1(0.44)	25.0(0.98)	24.0(0.94)
14	3/4	FHM-GZ14-RT12-	50.5(1.99)	19.1(0.75)	24.4(0.96)	11.1(0.44)	25.0(0.98)	27.0(1.06)
15	1/2	FHM-GZ15-RT8-	49.0(1.93)	19.1(0.75)	24.4(0.96)	11.9(0.47)	25.0(0.98)	24.0(0.94)
16	1/4	FHM-GZ16-RT4-	44.1(1.74)	14.2(0.56)	24.4(0.96)	7.1(0.28)	25.0(0.98)	24.0(0.94)
16	3/8	FHM-GZ16-RT6-	44.1(1.74)	14.2(0.56)	24.4(0.96)	9.5(0.37)	25.0(0.98)	24.0(0.94)
16	1/2	FHM-GZ16-RT8-	49.0(1.93)	19.1(0.75)	24.4(0.96)	11.9(0.47)	25.0(0.98)	24.0(0.94)
16	3/4	FHM-GZ16-RT12-	50.5(1.99)	19.1(0.75)	24.4(0.96)	12.7(0.5)	25.0(0.98)	27.0(1.06)
18	1/2	FHM-GZ18-RT8-	50.5(1.99)	19.1(0.75)	24.4(0.96)	11.9(0.47)	30.0(1.18)	27.0(1.06)
18	3/4	FHM-GZ18-RT12-	50.5(1.99)	19.1(0.75)	24.4(0.96)	15.1(0.59)	30.0(1.18)	27.0(1.06)
20	1/2	FHM-GZ20-RT8-	52.3(2.06)	19.1(0.75)	26.0(1.02)	11.9(0.47)	32.0(1.26)	30.0(1.18)
20	3/4	FHM-GZ20-RT12-	52.3(2.06)	19.1(0.75)	26.0(1.02)	15.9(0.63)	32.0(1.26)	30.0(1.18)
22	3/4	FHM-GZ22-RT12-	52.3(2.06)	19.1(0.75)	26.0(1.02)	15.9(0.63)	32.0(1.26)	30.0(1.18)
22	1	FHM-GZ22-RT16-	57.1(2.25)	23.9(0.94)	26.0(1.02)	18.3(0.72)	32.0(1.26)	35.0(1.38)
25	1/2	FHM-GZ25-RT8-	57.5(2.26)	19.1(0.75)	31.3(1.23)	11.9(0.47)	38.0(1.50)	35.0(1.38)
25	3/4	FHM-GZ25-RT12-	57.5(2.26)	19.1(0.75)	31.3(1.23)	15.9(0.63)	38.0(1.50)	35.0(1.38)
25	1	FHM-GZ25-RT16-	62.3(2.45)	23.9(0.94)	31.3(1.23)	21.8(0.86)	38.0(1.50)	35.0(1.38)
28	1	FHM-GZ28-RT16-	72.4(2.85)	23.9(0.94)	36.6(1.44)	21.8(0.86)	46.0(1.81)	41.0(1.61)
28	1 1/4	FHM-GZ28-RT20-	73.1(2.88)	23.9(0.94)	36.6(1.44)	21.8(0.86)	46.0(1.81)	46.0(1.81)
30	1 1/4	FHM-GZ30-RT20-	77.2(3.04)	23.9(0.94)	39.6(1.56)	26.2(1.03)	50.0(1.97)	46.0(1.81)
32	1 1/4	FHM-GZ32-RT20-	79.6(3.13)	23.9(0.94)	42.0(1.65)	28.6(1.13)	50.0(1.97)	46.0(1.81)
38	1 1/2	FHM-GZ38-RT24-	91.6(3.61)	26.2(1.03)	49.4(1.94)	33.7(1.33)	60.0(2.36)	55.0(2.17)

## Штуцер с наружной резьбой

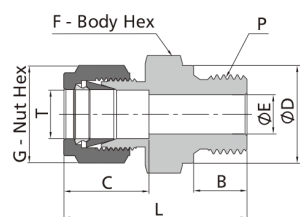

Размер E наименьший номинальный размер.

Метрическая трубка			Цилиндрическая резьба ISO (RS)						
Т-трубка O.D. (мм.)	Размер резьбы RS	Артикул	Размеры, дюймы. (мм)						
			L	B	C	E	G	F	D
2	1/8	FHM-GZ2-RS2-	30.0(1.18)	7.1(0.28)	12.9(0.51)	1.7(0.07)	12.0(0.47)	14.0(0.55)	13.7(0.54)
3	1/8	FHM-GZ3-RS2-	30.0(1.18)	7.1(0.28)	12.9(0.51)	2.4(0.09)	12.0(0.47)	14.0(0.55)	13.7(0.54)
3	1/4	FHM-GZ3-RS4-	35.3(1.39)	11.2(0.44)	12.9(0.51)	2.4(0.09)	12.0(0.47)	19.0(0.75)	18.0(0.71)
4	1/8	FHM-GZ4-RS2-	30.7(1.21)	7.1(0.28)	13.7(0.54)	2.4(0.09)	12.0(0.47)	14.0(0.55)	13.7(0.54)
4	1/4	FHM-GZ4-RS4-	36.0(1.42)	11.2(0.44)	13.7(0.54)	2.4(0.09)	12.0(0.47)	19.0(0.75)	18.0(0.71)
6	1/8	FHM-GZ6-RS2-	32.3(1.27)	7.1(0.28)	15.3(0.60)	4.0(0.16)	14.0(0.55)	14.0(0.55)	13.7(0.54)
6	1/4	FHM-GZ6-RS4-	37.6(1.48)	11.2(0.44)	15.3(0.60)	4.8(0.19)	14.0(0.55)	19.0(0.75)	18.0(0.71)
6	3/8	FHM-GZ6-RS6-	38.9(1.53)	11.2(0.44)	15.3(0.60)	4.8(0.19)	14.0(0.55)	22.0(0.87)	21.6(0.85)
6	1/2	FHM-GZ6-RS8-	44.7(1.76)	14.2(0.56)	15.3(0.60)	4.8(0.19)	14.0(0.55)	27.0(1.06)	25.9(1.02)
8	1/8	FHM-GZ8-RS2-	33.2(1.31)	7.1(0.28)	16.2(0.64)	4.0(0.16)	16.0(0.63)	15.0(0.59)	13.7(0.54)
8	1/4	FHM-GZ8-RS4-	38.5(1.52)	11.2(0.44)	16.2(0.64)	6.4(0.25)	16.0(0.63)	19.0(0.75)	18.0(0.71)
8	3/8	FHM-GZ8-RS6-	39.8(1.57)	11.2(0.44)	16.2(0.64)	6.4(0.25)	16.0(0.63)	22.0(0.87)	21.6(0.85)
8	1/2	FHM-GZ8-RS8-	45.6(1.80)	14.2(0.56)	16.2(0.64)	6.4(0.25)	16.0(0.63)	27.0(1.06)	25.9(1.02)
8	3/4	FHM-GZ8-RS12-	49.5(1.95)	15.7(0.62)	16.2(0.64)	6.4(0.25)	16.0(0.63)	35.0(1.38)	32.0(1.26)
10	1/4	FHM-GZ10-RS4-	39.4(1.55)	11.2(0.44)	17.2(0.68)	5.9(0.23)	19.0(0.75)	19.0(0.75)	18.0(0.71)
10	3/8	FHM-GZ10-RS6-	40.6(1.60)	11.2(0.44)	17.2(0.68)	7.9(0.31)	19.0(0.75)	22.0(0.87)	21.6(0.85)
10	1/2	FHM-GZ10-RS8-	46.5(1.83)	14.2(0.56)	17.2(0.68)	7.9(0.31)	19.0(0.75)	27.0(1.06)	25.9(1.02)
12	1/4	FHM-GZ12-RS4-	42.6(1.68)	11.2(0.44)	22.8(0.90)	5.9(0.23)	22.0(0.87)	22.0(0.87)	18.0(0.71)
12	3/8	FHM-GZ12-RS6-	43.1(1.70)	11.2(0.44)	22.8(0.90)	7.9(0.31)	22.0(0.87)	22.0(0.87)	21.6(0.85)
12	1/2	FHM-GZ12-RS8-	49.0(1.93)	14.2(0.56)	22.8(0.90)	9.5(0.37)	22.0(0.87)	27.0(1.06)	25.9(1.02)
12	3/4	FHM-GZ12-RS12-	52.8(2.08)	15.7(0.62)	22.8(0.90)	9.5(0.37)	22.0(0.87)	35.0(1.38)	32.0(1.26)
14	1/4	FHM-GZ14-RS4-	44.2(1.74)	11.2(0.44)	24.4(0.96)	6.4(0.25)	25.0(0.98)	24.0(0.94)	18.0(0.71)
14	3/8	FHM-GZ14-RS6-	43.9(1.73)	11.2(0.44)	24.4(0.96)	7.9(0.31)	25.0(0.98)	24.0(0.94)	21.6(0.85)
14	1/2	FHM-GZ14-RS8-	49.0(1.93)	14.2(0.56)	24.4(0.96)	11.1(0.44)	25.0(0.98)	27.0(1.06)	25.9(1.02)
14	3/4	FHM-GZ14-RS12-	52.8(2.08)	15.7(0.62)	24.4(0.96)	11.1(0.44)	25.0(0.98)	35.0(1.38)	32.0(1.26)
15	3/8	FHM-GZ15-RS6-	43.9(1.73)	11.2(0.44)	24.4(0.96)	7.9(0.31)	25.0(0.98)	24.0(0.94)	21.6(0.85)
15	1/2	FHM-GZ15-RS8-	49.0(1.93)	14.2(0.56)	24.4(0.96)	11.9(0.47)	25.0(0.98)	27.0(1.06)	25.9(1.02)
15	3/4	FHM-GZ15-RS12-	52.8(2.08)	15.7(0.62)	24.4(0.96)	11.9(0.47)	25.0(0.98)	35.0(1.38)	32.0(1.26)
16	3/8	FHM-GZ16-RS6-	43.9(1.73)	11.2(0.44)	24.4(0.96)	7.9(0.31)	25.0(0.98)	24.0(0.94)	21.6(0.85)
16	1/2	FHM-GZ16-RS8-	49.0(1.93)	14.2(0.56)	24.4(0.96)	11.9(0.47)	25.0(0.98)	27.0(1.06)	25.9(1.02)
16	3/4	FHM-GZ16-RS12-	52.8(2.08)	15.7(0.62)	24.4(0.96)	12.7(0.5)	25.0(0.98)	35.0(1.38)	32.0(1.26)
18	1/2	FHM-GZ18-RS8-	49.0(1.93)	14.2(0.56)	24.4(0.96)	11.9(0.47)	30.0(1.18)	27.0(1.06)	25.9(1.02)
18	3/4	FHM-GZ18-RS12-	52.8(2.08)	15.7(0.62)	24.4(0.96)	15.1(0.59)	30.0(1.18)	35.0(1.38)	32.0(1.26)
20	1/2	FHM-GZ20-RS8-	50.5(1.99)	14.2(0.56)	26.0(1.02)	11.9(0.47)	32.0(1.26)	30.0(1.18)	25.9(1.02)
20	3/4	FHM-GZ20-RS12-	52.8(2.08)	15.7(0.62)	26.0(1.02)	15.9(0.63)	32.0(1.26)	35.0(1.38)	32.0(1.26)
22	3/4	FHM-GZ22-RS12-	52.8(2.08)	15.7(0.62)	26.0(1.02)	15.9(0.63)	32.0(1.26)	35.0(1.38)	32.0(1.26)
22	1	FHM-GZ22-RS16-	55.3(2.18)	18.3(0.72)	26.0(1.02)	18.3(0.72)	32.0(1.26)	41.0(1.61)	39.1(1.54)
25	3/4	FHM-GZ25-RS12-	57.5(2.26)	15.7(0.62)	31.3(1.23)	15.9(0.63)	38.0(1.50)	35.0(1.38)	32.0(1.26)
25	1	FHM-GZ25-RS16-	60.1(2.37)	18.3(0.72)	31.3(1.23)	19.8(0.78)	38.0(1.50)	41.0(1.61)	39.1(1.54)
28	1	FHM-GZ28-RS16-	70.1(2.76)	18.3(0.72)	36.6(1.44)	19.8(0.78)	46.0(1.81)	41.0(1.61)	39.1(1.54)
28	1 1/4	FHM-GZ28-RS20-	73.9(2.91)	19.8(0.78)	36.6(1.44)	21.8(0.86)	46.0(1.81)	50.0(1.97)	49.0(1.93)
30	1 1/4	FHM-GZ30-RS20-	79.2(3.12)	19.8(0.78)	39.6(1.56)	26.2(1.03)	50.0(1.97)	50.0(1.97)	49.0(1.93)
32	1 1/4	FHM-GZ32-RS20-	78.9(3.11)	19.8(0.78)	42.0(1.65)	28.6(1.13)	50.0(1.97)	50.0(1.97)	49.0(1.93)
38	1 1/2	FHM-GZ38-RS24-	90.8(3.57)	20.6(0.81)	49.4(1.94)	31.8(1.25)	60.0(2.36)	55.0(2.17)	54.7(2.15)

# Размеры

## Штуцер с наружной резьбой

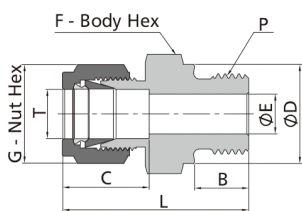

Размер Е наименьший номинальный размер.

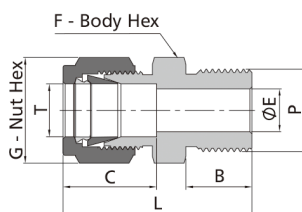

Размер Е наименьший номинальный размер.

### Метрическая трубка

### Цилиндрическая резьба ISO (RP)

Т-трубка O.D. (мм.)	Размер резьбы RP	Артикул	Размеры, дюймы. (мм)						
			L	B	C	E	G	F	D
3	1/8	FHM-GZ3-RP2-	30.0(1.18)	7.1(0.28)	12.9(0.51)	2.4(0.09)	12.0(0.47)	14.0(0.55)	13.8(0.54)
3	1/4	FHM-GZ3-RP4-	35.3(1.39)	11.2(0.44)	12.9(0.51)	2.4(0.09)	12.0(0.47)	19.0(0.75)	18.0(0.71)
4	1/8	FHM-GZ4-RP2-	30.7(1.21)	7.1(0.28)	13.7(0.54)	2.4(0.09)	12.0(0.47)	14.0(0.55)	13.8(0.54)
6	1/8	FHM-GZ6-RP2-	32.3(1.27)	7.1(0.28)	15.3(0.60)	4.0(0.16)	14.0(0.55)	14.0(0.55)	13.8(0.54)
6	1/4	FHM-GZ6-RP4-	37.6(1.48)	11.2(0.44)	15.3(0.60)	4.8(0.19)	14.0(0.55)	19.0(0.75)	18.0(0.71)
6	3/8	FHM-GZ6-RP6-	38.9(1.53)	11.2(0.44)	15.3(0.60)	4.8(0.19)	14.0(0.55)	22.0(0.87)	21.8(0.86)
6	1/2	FHM-GZ6-RP8-	44.7(1.76)	14.2(0.56)	15.3(0.60)	4.8(0.19)	14.0(0.55)	27.0(1.06)	26.0(1.02)
8	1/8	FHM-GZ8-RP2-	33.3(1.31)	7.1(0.28)	16.2(0.64)	4.0(0.16)	16.0(0.63)	15.0(0.59)	13.8(0.54)
8	1/4	FHM-GZ8-RP4-	38.5(1.52)	11.2(0.44)	16.2(0.64)	5.9(0.23)	16.0(0.63)	19.0(0.75)	18.0(0.71)
8	3/8	FHM-GZ8-RP6-	39.8(1.57)	11.2(0.44)	16.2(0.64)	6.4(0.25)	16.0(0.63)	22.0(0.87)	21.8(0.86)
8	1/2	FHM-GZ8-RP8-	45.6(1.80)	14.2(0.56)	16.2(0.64)	6.4(0.25)	16.0(0.63)	27.0(1.06)	26.0(1.02)
10	1/4	FHM-GZ10-RP4-	39.4(1.55)	11.2(0.44)	17.2(0.68)	5.9(0.23)	19.0(0.75)	19.0(0.75)	18.0(0.71)
10	3/8	FHM-GZ10-RP6-	42.8(1.69)	11.2(0.44)	17.2(0.68)	7.9(0.31)	19.0(0.75)	22.0(0.87)	21.8(0.86)
10	1/2	FHM-GZ10-RP8-	46.5(1.83)	14.2(0.56)	17.2(0.68)	7.9(0.31)	19.0(0.75)	27.0(1.06)	26.0(1.02)
12	1/4	FHM-GZ12-RP4-	42.6(1.68)	11.2(0.44)	22.8(0.90)	5.9(0.23)	22.0(0.87)	22.0(0.87)	18.0(0.71)
12	3/8	FHM-GZ12-RP6-	43.1(1.70)	11.2(0.44)	22.8(0.90)	7.9(0.31)	22.0(0.87)	22.0(0.87)	21.8(0.86)
12	1/2	FHM-GZ12-RP8-	52.1(2.05)	14.2(0.56)	22.8(0.90)	9.5(0.37)	22.0(0.87)	27.0(1.06)	26.0(1.02)
12	3/4	FHM-GZ12-RP12-	52.8(2.08)	15.7(0.62)	22.8(0.90)	9.5(0.37)	22.0(0.87)	35.0(1.38)	32.0(1.26)
15	1/2	FHM-GZ15-RP8-	47.5(1.87)	14.2(0.56)	24.4(0.96)	11.9(0.47)	25.0(0.98)	27.0(1.06)	26.0(1.02)
16	3/8	FHM-GZ16-RP6-	43.9(1.73)	11.2(0.44)	24.4(0.96)	7.9(0.31)	25.0(0.98)	24.0(0.94)	21.8(0.86)
16	1/2	FHM-GZ16-RP8-	49.0(1.93)	14.2(0.56)	24.4(0.96)	11.9(0.47)	25.0(0.98)	27.0(1.06)	26.0(1.02)
18	1/2	FHM-GZ18-RP8-	49.0(1.93)	14.2(0.56)	24.4(0.96)	11.9(0.47)	30.0(1.18)	27.0(1.06)	26.0(1.02)
18	3/4	FHM-GZ18-RP12-	52.8(2.08)	15.7(0.62)	24.4(0.96)	15.1(0.59)	30.0(1.18)	35.0(1.38)	32.0(1.26)
20	1/2	FHM-GZ20-RP8-	50.5(1.99)	14.2(0.56)	26.0(1.02)	11.9(0.47)	32.0(1.26)	30.0(1.18)	26.0(1.02)
20	3/4	FHM-GZ20-RP12-	52.8(2.08)	15.7(0.62)	26.0(1.02)	15.9(0.63)	32.0(1.26)	35.0(1.38)	32.0(1.26)
22	3/4	FHM-GZ22-RP12-	52.8(2.08)	15.7(0.62)	26.0(1.02)	15.9(0.63)	32.0(1.26)	35.0(1.38)	32.0(1.26)
22	1	FHM-GZ22-RP16-	55.3(2.18)	18.3(0.72)	26.0(1.02)	18.3(0.72)	32.0(1.26)	41.0(1.61)	39.0(1.54)
25	3/4	FHM-GZ25-RP12-	57.5(2.26)	15.7(0.62)	31.3(1.23)	15.9(0.63)	38.0(1.50)	35.0(1.38)	32.0(1.26)
25	1	FHM-GZ25-RP16-	60.1(2.37)	18.3(0.72)	31.3(1.23)	19.8(0.78)	38.0(1.50)	41.0(1.61)	39.0(1.54)
28	1	FHM-GZ28-RP16-	70.1(2.76)	18.3(0.72)	36.6(1.44)	19.8(0.78)	46.0(1.81)	41.0(1.61)	39.0(1.54)
28	1 1/4	FHM-GZ28-RP20-	73.9(2.91)	19.8(0.78)	36.6(1.44)	21.8(0.86)	46.0(1.81)	50.0(1.97)	49.0(1.93)
30	1 1/4	FHM-GZ30-RP20-	76.5(3.01)	19.8(0.78)	39.6(1.56)	26.2(1.03)	50.0(1.97)	50.0(1.97)	49.0(1.93)
32	1 1/4	FHM-GZ32-RP20-	78.9(3.11)	19.8(0.78)	42.0(1.65)	28.6(1.13)	50.0(1.97)	50.0(1.97)	49.0(1.93)
38	1 1/2	FHM-GZ38-RP24-	89.3(3.52)	20.6(0.81)	49.4(1.94)	31.8(1.25)	60.0(2.36)	55.0(2.17)	54.7(2.15)

### Метрическая трубка

### Цилиндрическая резьба ISO (BP)

Т-трубка O.D. (мм.)	Размер резьбы BP	Артикул	Размеры, дюймы. (мм)					
			L	B	C	E	G	F
6	1/4	FHM-GZ6-BP4-	36.9(1.45)	12.9(0.51)	15.3(0.60)	4.8(0.19)	14.0(0.55)	14.0(0.55)
6	3/8	FHM-GZ6-BP6-	39.5(1.56)	14.2(0.56)	15.3(0.60)	4.8(0.19)	14.0(0.55)	18.0(0.71)
8	1/8	FHM-GZ8-BP2-	33.9(1.33)	9.8(0.39)	16.2(0.64)	4.0(0.16)	16.0(0.63)	14.0(0.55)
8	1/4	FHM-GZ8-BP4-	37.0(1.46)	12.9(0.51)	16.2(0.64)	6.4(0.25)	16.0(0.63)	14.0(0.55)
8	3/8	FHM-GZ8-BP6-	39.3(1.55)	14.2(0.56)	16.2(0.64)	6.4(0.25)	16.0(0.63)	18.0(0.71)
8	1/2	FHM-GZ8-BP8-	45.4(1.79)	18.8(0.74)	16.2(0.64)	6.4(0.25)	16.0(0.63)	22.0(0.87)
10	1/4	FHM-GZ10-BP4-	39.5(1.56)	12.9(0.51)	17.2(0.68)	5.9(0.23)	19.0(0.75)	18.0(0.71)
10	1/2	FHM-GZ10-BP8-	46.3(1.82)	18.8(0.74)	17.2(0.68)	7.9(0.31)	19.0(0.75)	22.0(0.87)
12	3/8	FHM-GZ12-BP6-	44.2(1.74)	14.2(0.56)	22.8(0.90)	7.9(0.31)	22.0(0.87)	22.0(0.87)
12	1/2	FHM-GZ12-BP8-	52.1(2.05)	18.8(0.74)	22.8(0.90)	9.5(0.37)	22.0(0.87)	22.0(0.87)
14	1/4	FHM-GZ14-BP4-	42.9(1.69)	12.9(0.51)	24.4(0.96)	5.9(0.23)	25.0(0.98)	24.0(0.94)
16	3/8	FHM-GZ16-BP6-	43.4(1.71)	14.2(0.56)	24.4(0.96)	7.9(0.31)	25.0(0.98)	24.0(0.94)
16	1/2	FHM-GZ16-BP8-	47.9(1.89)	18.8(0.74)	24.4(0.96)	9.5(0.37)	25.0(0.98)	24.0(0.94)
18	1/2	FHM-GZ18-BP8-	49.8(1.96)	18.8(0.74)	24.4(0.96)	9.5(0.37)	30.0(1.18)	27.0(1.06)

## Штуцер с наружной резьбой

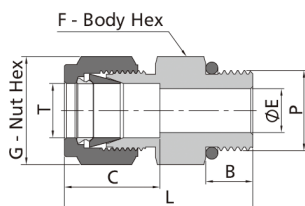

1. Размер E наименьший номинальный размер.

2. Прямая резьба согласно SAE J1926-1, ISO 11926-1 и MS 16142.

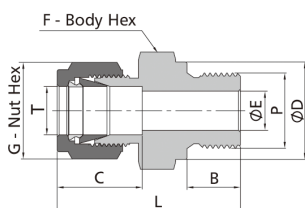

Размер E наименьший номинальный размер.

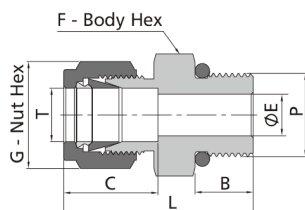

1. Размер E наименьший номинальный размер.

2. Прямая резьба согласно ISO 6149-1.

### Метрическая трубка

Т-трубка O.D. (мм.)	Размер резьбы MS	Спецификация резьбы P-SAE/MS	Артикул	Прямая резьба SAE/MS (ST)					
				Dimensions, in. (mm)					
				L	B	C	E	G	F
6	6	9/16-18	FHM-GZ6-ST9-	35.6(1.40)	9.9(0.39)	15.3(0.60)	4.8(0.19)	14.0(0.55)	18.0(0.71)
10	6	9/16-18	FHM-GZ10-ST9-	37.3(1.47)	9.9(0.39)	17.2(0.68)	7.1(0.28)	19.0(0.75)	18.0(0.71)
10	8	3/4-16	FHM-GZ10-ST12-	39.4(1.55)	11.2(0.44)	17.2(0.68)	7.9(0.31)	19.0(0.75)	22.0(0.87)
12	4	7/16-20	FHM-GZ12-ST7-	40.6(1.60)	9.1(0.36)	22.8(0.90)	5.2(0.20)	22.0(0.87)	22.0(0.87)
12	6	9/16-18	FHM-GZ12-ST9-	39.9(1.57)	9.9(0.39)	22.8(0.90)	7.1(0.28)	22.0(0.87)	22.0(0.87)

### Метрическая трубка

Т-трубка O.D. (мм.)	Размер резьбы MRS	Артикул	Метрическая резьба (MRS)						
			Размеры, дюймы. (мм)						
			L	B	C	E	G	F	D
6	M8 × 1	FHM-GZ6-MRS8-	33.3(1.31)	8.0(0.31)	8.0(0.31)	3.0(0.12)	14.0(0.55)	14.0(0.55)	12.0(0.47)
6	M10 × 1	FHM-GZ6-MRS10-	33.3(1.31)	8.0(0.31)	8.0(0.31)	4.0(0.16)	14.0(0.55)	14.0(0.55)	14.0(0.55)
6	M12 × 1.5	FHM-GZ6-MRS12-	38.2(1.50)	12.0(0.47)	12.0(0.47)	4.8(0.19)	14.0(0.55)	18.0(0.71)	17.0(0.67)
6	M14 × 1.5	FHM-GZ6-MRS14-	39.7(1.56)	12.0(0.47)	12.0(0.47)	4.8(0.19)	14.0(0.55)	22.0(0.87)	19.0(0.75)
8	M8 × 1	FHM-GZ8-MRS8-	34.1(1.34)	8.0(0.31)	8.0(0.31)	3.0(0.12)	16.0(0.63)	14.0(0.55)	12.0(0.47)
8	M10 × 1	FHM-GZ8-MRS10-	34.1(1.34)	8.0(0.31)	8.0(0.31)	5.0(0.20)	16.0(0.63)	14.0(0.55)	14.0(0.55)
8	M12 × 1.5	FHM-GZ8-MRS12-	40.4(1.59)	12.0(0.47)	12.0(0.47)	6.0(0.24)	16.0(0.63)	18.0(0.71)	17.0(0.67)
8	M14 × 1.5	FHM-GZ8-MRS14-	40.4(1.59)	12.0(0.47)	12.0(0.47)	6.4(0.25)	16.0(0.63)	19.0(0.75)	19.0(0.75)
10	M12 × 1.5	FHM-GZ10-MRS12-	40.7(1.60)	12.0(0.47)	12.0(0.47)	6.0(0.24)	19.0(0.75)	18.0(0.71)	17.0(0.67)
10	M14 × 1.5	FHM-GZ10-MRS14-	39.5(1.56)	12.0(0.47)	12.0(0.47)	7.9(0.31)	19.0(0.75)	19.0(0.75)	19.0(0.75)
12	M16 × 1.5	FHM-GZ12-MRS16-	45.5(1.79)	12.0(0.47)	12.0(0.47)	9.0(0.35)	22.0(0.87)	22.0(0.87)	21.0(0.83)
12	M20 × 1.5	FHM-GZ12-MRS20-	47.2(1.86)	14.0(0.55)	14.0(0.55)	9.5(0.37)	22.0(0.87)	25.0(0.98)	25.0(0.98)
12	M22 × 1.5	FHM-GZ12-MRS22-	47.5(1.87)	14.0(0.55)	14.0(0.55)	9.5(0.37)	22.0(0.87)	27.0(1.06)	27.0(1.06)
14	M14 × 1.5	FHM-GZ14-MRS14-	44.9(1.77)	12.0(0.47)	12.0(0.47)	8.0(0.31)	25.0(0.98)	24.0(0.94)	19.0(0.75)
14	M20 × 1.5	FHM-GZ14-MRS20-	48.0(1.89)	14.0(0.55)	14.0(0.55)	11.1(0.44)	25.0(0.98)	27.0(1.06)	25.0(0.98)
16	M20 × 1.5	FHM-GZ16-MRS20-	48.0(1.89)	14.0(0.55)	14.0(0.55)	12.0(0.47)	25.0(0.98)	25.0(0.98)	25.0(0.98)
18	M20 × 1.5	FHM-GZ18-MRS20-	48.5(1.91)	14.0(0.55)	14.0(0.55)	12.0(0.47)	30.0(1.18)	27.0(1.06)	25.0(0.98)
20	M20 × 1.5	FHM-GZ20-MRS20-	50.0(1.97)	14.0(0.55)	14.0(0.55)	12.0(0.47)	32.0(1.26)	30.0(1.18)	25.0(0.98)
22	M24 × 1.5	FHM-GZ22-MRS24-	50.5(1.99)	14.0(0.55)	14.0(0.55)	15.0(0.59)	32.0(1.26)	30.0(1.18)	28.8(1.13)
25	M27 × 2	FHM-GZ25-MRS27-	57.5(2.26)	16.0(0.63)	16.0(0.63)	16.8(0.66)	38.0(1.50)	35.0(1.38)	32.0(1.26)

### Метрическая трубка

Т-трубка O.D. (мм.)	Размер резьбы SAE	Артикул	Прямая резьба SAE/MS (ST)					
			Размеры, дюймы. (мм)					
			L	B	C	E	G	F
6	M14 × 1.5	FHM-GZ6-MST14-	38.7(1.52)	11.0(0.43)	15.3(0.60)	4.8(0.19)	14.0(0.55)	19.0(0.75)
10	M14 × 1.5	FHM-GZ10-MST14-	40.0(1.57)	11.0(0.43)	17.2(0.68)	7.5(0.30)	19.0(0.75)	19.0(0.75)
10	M20 × 1.5	FHM-GZ10-MST20-	47.2(1.86)	14.0(0.55)	17.2(0.68)	7.9(0.31)	19.0(0.75)	27.0(1.06)
12	M14 × 1.5	FHM-GZ12-MST14-	40.2(1.58)	11.0(0.43)	22.8(0.90)	7.5(0.30)	22.0(0.87)	22.0(0.87)
12	M20 × 1.5	FHM-GZ12-MST20-	47.2(1.86)	14.0(0.55)	22.8(0.90)	9.5(0.37)	22.0(0.87)	27.0(1.06)

# Размеры

## Штуцер с наружной резьбой

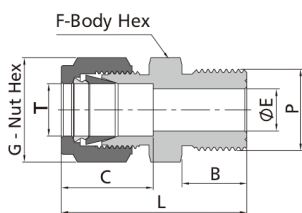

Размер E наименьший номинальный размер.

### Метрическая трубка

### Метрическая резьба (MS)

Т-трубка O.D. (мм.)	Размер резьбы MS	Артикул	Размеры, дюймы. (мм)					
			L	B	C	E	G	F
6	M6 × 1	FHM-GZ6-MS6-	32.4(1.28)	8.0(0.31)	2.0(0.08)	2.0(0.08)	14.0(0.55)	14.0(0.55)
6	M8 × 1	FHM-GZ6-MS8-	35.3(1.39)	9.0(0.35)	3.0(0.12)	3.0(0.12)	14.0(0.55)	14.0(0.55)
6	M10 × 1	FHM-GZ6-MS10-	34.7(1.37)	11.0(0.43)	4.7(0.19)	4.7(0.19)	14.0(0.55)	14.0(0.55)
6	M12 × 1.5	FHM-GZ6-MS12-	36.4(1.43)	12.0(0.47)	4.8(0.19)	4.8(0.19)	14.0(0.55)	14.0(0.55)
6	M14 × 1.5	FHM-GZ6-MS14-	36.5(1.44)	13.0(0.51)	4.8(0.19)	4.8(0.19)	14.0(0.55)	16.0(0.63)
6	M16 × 1.5	FHM-GZ6-MS16-	38.4(1.51)	14.0(0.55)	4.8(0.19)	4.8(0.19)	14.0(0.55)	18.0(0.71)
6	M18 × 1.5	FHM-GZ6-MS18-	40.0(1.57)	15.0(0.59)	4.8(0.19)	4.8(0.19)	14.0(0.55)	19.0(0.75)
6	M20 × 1.5	FHM-GZ6-MS20-	41.7(1.64)	16.0(0.63)	4.8(0.19)	4.8(0.19)	14.0(0.55)	22.0(0.87)
8	M8 × 1	FHM-GZ8-MS8-	34.5(1.36)	9.0(0.35)	3.0(0.12)	3.0(0.12)	16.0(0.63)	14.0(0.55)
8	M10 × 1	FHM-GZ8-MS10-	36.6(1.44)	11.0(0.43)	4.7(0.19)	4.7(0.19)	16.0(0.63)	14.0(0.55)
8	M12 × 1.5	FHM-GZ8-MS12-	36.6(1.44)	12.0(0.47)	6.0(0.24)	6.0(0.24)	16.0(0.63)	14.0(0.55)
8	M14 × 1.5	FHM-GZ8-MS14-	37.7(1.48)	13.0(0.51)	6.4(0.25)	6.4(0.25)	16.0(0.63)	16.0(0.63)
8	M20 × 1.5	FHM-GZ8-MS20-	42.5(1.67)	16.0(0.63)	6.4(0.25)	6.4(0.25)	16.0(0.63)	22.0(0.87)
10	M12 × 1.5	FHM-GZ10-MS12-	38.7(1.52)	12.0(0.47)	6.0(0.24)	6.0(0.24)	19.0(0.75)	18.0(0.71)
10	M14 × 1.5	FHM-GZ10-MS14-	39.7(1.56)	13.0(0.51)	7.2(0.28)	7.2(0.28)	19.0(0.75)	18.0(0.71)
10	M20 × 1.5	FHM-GZ10-MS20-	43.5(1.71)	16.0(0.63)	7.9(0.31)	7.9(0.31)	19.0(0.75)	22.0(0.87)
12	M12 × 1.5	FHM-GZ12-MS12-	41.2(1.62)	12.0(0.47)	6.0(0.24)	6.0(0.24)	22.0(0.87)	22.0(0.87)
12	M16 × 1.5	FHM-GZ12-MS16-	43.2(1.70)	14.0(0.55)	8.4(0.33)	8.4(0.33)	22.0(0.87)	22.0(0.87)
12	M18 × 1.5	FHM-GZ12-MS18-	44.2(1.74)	15.0(0.59)	9.5(0.37)	9.5(0.37)	22.0(0.87)	22.0(0.87)
12	M20 × 1.5	FHM-GZ12-MS20-	45.2(1.78)	16.0(0.63)	9.5(0.37)	9.5(0.37)	22.0(0.87)	22.0(0.87)
14	M14 × 1.5	FHM-GZ14-MS14-	42.5(1.67)	13.0(0.51)	7.2(0.28)	7.2(0.28)	25.0(0.98)	24.0(0.94)
14	M16 × 1.5	FHM-GZ14-MS16-	43.9(1.73)	14.0(0.55)	8.4(0.33)	8.4(0.33)	25.0(0.98)	24.0(0.94)
14	M20 × 1.5	FHM-GZ14-MS20-	45.1(1.78)	16.0(0.63)	10.8(0.43)	10.8(0.43)	25.0(0.98)	24.0(0.94)
16	M20 × 1.5	FHM-GZ16-MS20-	46.1(1.81)	16.0(0.63)	10.8(0.43)	10.8(0.43)	25.0(0.98)	24.0(0.94)
18	M20 × 1.5	FHM-GZ18-MS20-	47.5(1.87)	16.0(0.63)	10.8(0.43)	10.8(0.43)	30.0(1.18)	27.0(1.06)
18	M22 × 1.5	FHM-GZ18-MS22-	48.5(1.91)	17.0(0.67)	12.0(0.47)	12.0(0.47)	30.0(1.18)	27.0(1.06)
20	M20 × 1.5	FHM-GZ20-MS20-	49.5(1.95)	16.0(0.63)	10.8(0.43)	10.8(0.43)	32.0(1.26)	30.0(1.18)
22	M24 × 1.5	FHM-GZ22-MS24-	50.5(1.99)	17.0(0.67)	14.4(0.57)	14.4(0.57)	32.0(1.26)	30.0(1.18)
25	M27 × 2	FHM-GZ25-MS27-	57.0(2.24)	18.0(0.71)	16.1(0.63)	16.1(0.63)	38.0(1.50)	35.0(1.38)



## Штуцер с наружной резьбой и монтажной гайкой

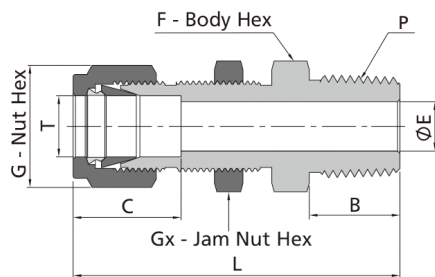

Размер E наименьший номинальный размер.

### Дюймовая трубка Резьба NPT

Т-трубка (дюймы.)	P-NPT Резьба	Артикул	Размеры, дюймы. (мм)							Размер отверстия в панели дюймы. (мм)	Макс толщина панели дюймы. (мм)
			L	B	C	E	G	F	Gx		
1/16	1/16	FHMN-YZ1-NPT1 -	1.19(30.2)	0.38(9.7)	0.34(8.6)	0.05(1.3)	0.31(7.9)	0.31(7.9)	0.31(7.9)	0.20(5.2)	0.25(6.4)
1/16	1/8	FHMN-YZ1-NPT2-	1.27(32.3)	0.38(9.7)	0.34(8.6)	0.05(1.3)	0.31(7.9)	0.44(11.1)	0.31(7.9)	0.20(5.2)	0.25(6.4)
1/8	1/8	FHMN-YZ2-NPT2-	1.83(46.5)	0.38(9.7)	0.50(12.7)	0.09(2.3)	0.44(11.1)	0.50(12.7)	0.50(12.7)	0.33(8.3)	0.50(12.7)
3/16	1/8	FHMN-YZ3-NPT2-	1.89(48.0)	0.38(9.7)	0.54(13.7)	0.12(3.0)	0.50(12.7)	0.56(14.3)	0.56(14.3)	0.39(9.9)	0.50(12.7)
1/4	1/8	FHMN-YZ4-NPT2-	1.95(49.5)	0.38(9.7)	0.60(15.2)	0.19(4.8)	0.56(14.3)	0.63(15.9)	0.63(15.9)	0.45(11.5)	0.40(10.2)
1/4	1/4	FHMN-YZ4-NPT4-	2.13(54.1)	0.56(14.2)	0.60(15.2)	0.19(4.8)	0.56(14.3)	0.63(15.9)	0.63(15.9)	0.45(11.5)	0.40(10.2)
1/4	3/8	FHMN-YZ4-NPT6-	2.16(54.9)	0.56(14.2)	0.60(15.2)	0.19(4.8)	0.63(15.9)	0.69(17.5)	0.63(15.9)	0.45(11.5)	0.40(10.2)
1/4	1/2	FHMN-YZ4-NPT8-	2.37(60.3)	0.75(19.1)	0.60(15.2)	0.19(4.8)	0.56(14.3)	0.87(22.2)	0.63(15.9)	0.45(11.5)	0.40(10.2)
5/16	1/8	FHMN-YZ5-NPT2-	2.08(52.8)	0.38(9.7)	0.64(16.3)	0.19(4.8)	0.63(15.9)	0.69(17.5)	0.69(17.5)	0.52(13.1)	0.44(11.2)
5/16	1/4	FHMN-YZ5-NPT4-	2.27(57.7)	0.56(14.2)	0.64(16.3)	0.25(6.4)	0.63(15.9)	0.69(17.5)	0.69(17.5)	0.52(13.1)	0.44(11.2)
3/8	1/8	FHMN-YZ6-NPT2-	2.08(52.9)	0.38(9.7)	0.66(16.8)	0.19(4.8)	0.69(17.5)	0.75(19.1)	0.75(19.1)	0.58(14.7)	0.44(11.2)
3/8	1/4	FHMN-YZ6-NPT4-	2.26(57.4)	0.56(14.2)	0.66(16.8)	0.28(7.1)	0.69(17.5)	0.75(19.1)	0.75(19.1)	0.58(14.7)	0.44(11.2)
3/8	3/8	FHMN-YZ6-NPT6-	2.26(57.4)	0.56(14.2)	0.66(16.8)	0.28(7.1)	0.69(17.5)	0.75(19.1)	0.75(19.1)	0.58(14.7)	0.44(11.2)
3/8	1/2	FHMN-YZ6-NPT8-	2.51(63.8)	0.75(19.1)	0.66(16.8)	0.28(7.1)	0.69(17.5)	0.87(22.2)	0.87(22.2)	0.58(14.7)	0.44(11.2)
1/2	1/8	FHMN-YZ8-NPT2-	2.31(58.7)	0.38(9.7)	0.90(22.9)	0.19(4.8)	0.87(22.2)	0.94(23.8)	0.94(23.8)	0.76(19.4)	0.50(12.7)
1/2	1/4	FHMN-YZ8-NPT4-	2.49(63.2)	0.56(14.2)	0.90(22.9)	0.28(7.1)	0.87(22.2)	0.94(23.8)	0.94(23.8)	0.76(19.4)	0.50(12.7)
1/2	3/8	FHMN-YZ8-NPT6-	2.49(63.2)	0.56(14.2)	0.90(22.9)	0.38(9.7)	0.87(22.2)	0.94(23.8)	0.87(22.2)	0.76(19.4)	0.50(12.7)
1/2	1/2	FHMN-YZ8-NPT8-	2.71(68.8)	0.75(19.1)	0.90(22.9)	0.41(10.4)	0.87(22.2)	0.94(23.8)	0.94(23.8)	0.76(19.4)	0.50(12.7)
5/8	3/8	FHMN-YZ10-NPT6-	2.63(66.7)	0.56(14.2)	0.96(24.4)	0.38(9.7)	1.00(25.4)	1.06(27.0)	1.06(27.0)	0.89(22.6)	0.59(15.1)
5/8	1/2	FHMN-YZ10-NPT8-	2.81(71.5)	0.75(19.1)	0.96(24.4)	0.47(11.9)	1.00(25.4)	1.06(27.0)	1.06(27.0)	0.89(22.6)	0.59(15.1)
3/4	1/2	FHMN-YZ12-NPT8-	3.00(76.2)	0.75(19.1)	0.96(24.4)	0.47(11.9)	1.13(28.6)	1.19(30.2)	1.19(30.2)	1.02(25.8)	0.66(16.8)
3/4	3/4	FHMN-YZ12-NPT12-	3.00(76.2)	0.75(19.1)	0.96(24.4)	0.62(15.7)	1.13(28.6)	1.19(30.2)	1.19(30.2)	1.02(25.8)	0.66(16.8)
7/8	3/4	FHMN-YZ14-NPT12-	3.31(84.1)	0.75(19.1)	1.02(25.9)	0.62(15.7)	1.25(31.8)	1.31(33.3)	1.31(33.3)	1.14(29.0)	0.75(19.1)
1	3/4	FHMN-YZ16-NPT12-	3.48(88.4)	0.75(19.1)	1.23(31.2)	0.62(15.7)	1.50(38.1)	1.63(41.3)	1.63(41.3)	1.33(33.7)	0.75(19.1)
1	1	FHMN-YZ16-NPT16-	3.67(93.2)	0.94(23.9)	1.23(31.2)	0.88(22.4)	1.50(38.1)	1.63(41.3)	1.63(41.3)	1.33(33.7)	0.75(19.1)

### Метрическая трубка Резьба NPT

Т-Трубка (мм.)	P-NPT Резьба	Артикул	Размеры, дюймы (мм)							Размер отверстия в панели дюймы. (мм)	Макс толщина панели дюймы. (мм)
			L	B	C	E	G	F	Gx		
6	1/8	FHMN-GZ6-NPT2-	49.6(1.95)	9.7(0.38)	15.3(0.60)	4.8(0.19)	14.0(0.55)	16.0(0.63)	16.0(0.63)	11.5(0.45)	10.2(0.40)
6	1/4	FHMN-GZ6-NPT4-	53.6(2.11)	14.2(0.56)	15.3(0.60)	4.8(0.19)	14.0(0.55)	16.0(0.63)	16.0(0.63)	11.5(0.45)	10.2(0.40)
8	1/8	FHMN-GZ8-NPT2-	52.3(2.06)	9.7(0.38)	16.2(0.64)	4.8(0.19)	16.0(0.63)	18.0(0.71)	18.0(0.71)	13.1(0.52)	11.2(0.44)
8	1/4	FHMN-GZ8-NPT4-	56.6(2.23)	14.2(0.56)	16.2(0.64)	6.4(0.25)	16.0(0.63)	18.0(0.71)	18.0(0.71)	13.1(0.52)	11.2(0.44)
10	1/4	FHMN-GZ10-NPT4-	58.4(2.30)	14.2(0.56)	17.2(0.68)	7.1(0.28)	19.0(0.75)	22.0(0.87)	22.0(0.87)	16.3(0.64)	11.2(0.44)
10	3/8	FHMN-GZ10-NPT6-	58.4(2.30)	14.2(0.56)	17.2(0.68)	7.9(0.31)	19.0(0.75)	22.0(0.87)	22.0(0.87)	16.3(0.64)	11.2(0.44)
10	1/2	FHMN-GZ10-NPT8-	63.1(2.48)	19.1(0.75)	17.2(0.68)	7.9(0.31)	19.0(0.75)	22.0(0.87)	22.0(0.87)	16.3(0.64)	11.2(0.44)
12	1/4	FHMN-GZ12-NPT4-	63.9(2.52)	14.2(0.56)	22.8(0.90)	7.1(0.28)	22.0(0.87)	24.0(0.94)	24.0(0.94)	19.5(0.77)	12.7(0.50)
12	3/8	FHMN-GZ12-NPT6-	63.9(2.52)	14.2(0.56)	22.8(0.90)	9.5(0.37)	22.0(0.87)	24.0(0.94)	24.0(0.94)	19.5(0.77)	12.7(0.50)
12	1/2	FHMN-GZ12-NPT8-	68.8(2.71)	19.1(0.75)	22.8(0.90)	9.5(0.37)	22.0(0.87)	24.0(0.94)	24.0(0.94)	19.5(0.77)	12.7(0.50)

## Штуцер с наружной резьбой и монтажной гайкой

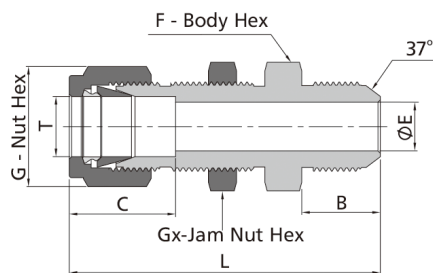

Размер E наименьший номинальный размер.

### Дюймовая трубка

### Резьба с уплотнительным конусом 37° (AN)

Т-Трубка (мм.)	P-AN Резьба	Артикул	Размеры, дюймы (мм)							Размер отверстия в панели дюймы. (мм)	Макс толщина панели дюймы. (мм)
			L	B	C	E	G	F	Gx		
1/8	1/8	FHMN-YZ2-AN2-	1.91(48.5)	0.45(11.4)	0.50(12.7)	0.06(1.5)	0.44(11.1)	0.50(12.7)	0.50(12.7)	0.33(8.3)	0.50(12.7)
1/8	1/4	FHMN-YZ2-AN4-	2.04(51.8)	0.55(14.0)	0.50(12.7)	0.09(2.3)	0.44(11.1)	0.63(15.9)	0.50(12.7)	0.33(8.3)	0.50(12.7)
3/16	3/16	FHMN-YZ3-AN3-	1.98(50.3)	0.48(12.2)	0.54(13.7)	0.12(3.0)	0.50(12.7)	0.56(14.3)	0.56(14.3)	0.39(9.9)	0.50(12.7)
1/4	1/4	FHMN-YZ4-AN4-	2.12(53.8)	0.55(14.0)	0.60(15.2)	0.17(4.3)	0.56(14.3)	0.63(15.9)	0.63(15.9)	0.45(11.5)	0.40(10.2)
5/16	5/16	FHMN-YZ5-AN5-	2.21(56.1)	0.55(14.0)	0.64(16.2)	0.23(5.8)	0.63(15.9)	0.69(17.5)	0.69(17.5)	0.52(13.1)	0.56(14.3)
3/8	1/4	FHMN-YZ6-AN4-	2.25(57.2)	0.55(14.0)	0.66(16.8)	0.17(4.3)	0.69(17.5)	0.75(19.1)	0.75(19.1)	0.58(14.7)	0.44(11.2)
3/8	3/8	FHMN-YZ6-AN6-	2.25(57.2)	0.56(14.2)	0.66(16.8)	0.28(7.1)	0.69(17.5)	0.75(19.1)	0.75(19.1)	0.58(14.7)	0.44(11.2)
1/2	1/2	FHMN-YZ8-AN8-	2.59(65.8)	0.66(16.8)	0.90(22.8)	0.39(9.9)	0.87(22.2)	0.94(23.8)	0.94(23.8)	0.76(19.4)	0.50(12.7)
5/8	5/8	FHMN-YZ10-AN10-	2.74(69.6)	0.76(19.3)	0.96(24.4)	0.48(12.3)	1.00(25.4)	1.06(27.0)	1.06(27.0)	0.89(22.6)	0.59(15.1)
3/4	3/4	FHMN-YZ12-AN12-	3.11(79.0)	0.86(21.8)	0.96(24.4)	0.61(15.5)	1.13(28.6)	1.19(30.2)	1.19(30.2)	1.02(25.8)	0.66(16.8)
1	1	FHMN-YZ16-AN16-	3.64(92.5)	0.91(23.1)	1.23(31.2)	0.84(21.3)	1.50(38.1)	1.63(41.3)	1.63(41.3)	1.33(33.7)	0.75(19.1)

## Муфта конечная

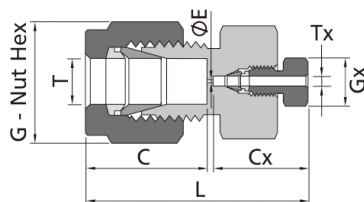

### Дюймовая трубка

Т-Трубка O.D. (дюймы)	Тх-Размер трубки	Артикул	Размеры, дюймы. (мм)						Объем
			L	C	Cx	E	G	Gx	
1/4	1/16	FURE-YZ4-NYZ1-	1.24(31.5)	0.60(15.2)	0.61(15.5)	0.01(0.3)	0.56(14.3)	0.25(6.4)	$6.8 \times 10^{-5} \text{ cm}^3$
3/8	1/16	FURE-YZ6-NYZ1-	1.30(33.0)	0.66(16.8)	0.61(15.5)	0.01(0.3)	0.69(17.5)	0.25(6.4)	$6.8 \times 10^{-5} \text{ cm}^3$

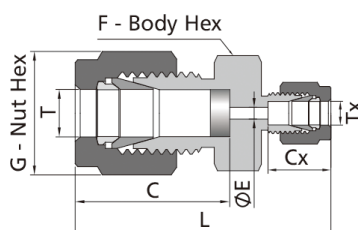

### Дюймовая трубка

Т-Трубка O.D. (дюймы)	Тх-Размер трубки	Артикул	Размеры, дюймы. (мм)						Объем
			L	C	Cx	G	F	E	
1/8	1/16	FURE-YZ2SN7-YZ1-	1.22(31.0)	0.72(18.3)	0.34(8.6)	0.44(11.1)	0.44(11.1)	0.05(1.3)	$5.4 \times 10^{-3} \text{ cm}^3$
1/4	1/16	FURE-YZ4SN7-YZ1-	1.35(34.3)	0.82(20.8)	0.34(8.6)	0.56(14.3)	0.50(12.7)	0.05(1.3)	$6.7 \times 10^{-3} \text{ cm}^3$
3/8	1/16	FURE-YZ6SN7-YZ1-	1.44(36.6)	0.91(23.1)	0.34(8.6)	0.69(17.5)	0.63(15.9)	0.05(1.3)	$6.5 \times 10^{-3} \text{ cm}^3$

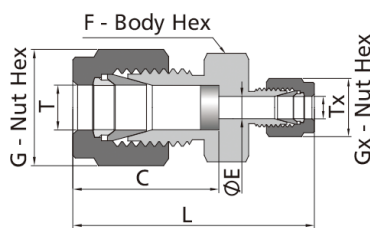

### Дюймовая трубка

Т-Трубка O.D. (дюймы)	Тх-Размер трубки	Артикул	Размеры, дюймы. (мм)						Объем
			L	C	G	Gx	F	E	
1/8	1/16	FURE-YZ2SN7-TYZ1-	1.22(31.0)	0.72(18.3)	0.44(11.1)	0.44(11.1)	0.44(11.1)	0.07(1.7)	0
1/4	1/16	FURE-YZ4SN7-TYZ1-	1.35(34.3)	0.82(20.8)	0.56(14.3)	0.50(12.7)	0.50(12.7)	0.07(1.7)	0
3/8	1/16	FURE-YZ6SN7-TYZ1-	1.44(36.6)	0.91(23.1)	0.69(17.5)	0.63(15.9)	0.63(15.9)	0.07(1.7)	0
1/2	1/16	FURE-YZ8SN7-TYZ1-	1.58(40.1)	1.04(26.4)	0.87(22.2)	0.81(20.6)	0.81(20.6)	0.07(1.7)	0

Nominal pore size of SN7 Stainless steel sinter is 7  $\mu\text{m}$ , and other nominal pore sizes are available. Stainless steel sinters are loosely installed to facilitate removal and replacement.

## Штуцер с внутренней резьбой

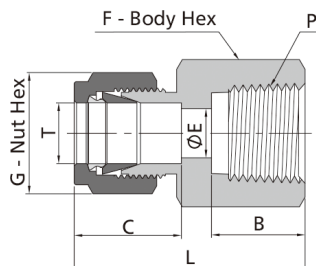

Дюймовая трубка			Резьба NPT					
Т-Трубка (дюймы)	Р-NPT Размер резьбы	Артикул	Размеры, дюймы. (мм)					
			L	B	C	E	G	F
1/16	1/16	FHM-YZ1 -NPT1-	0.93(23.6)	0.39(9.9)	0.34(8.6)	0.05(1.3)	0.31(7.9)	0.44(11.1)
1/16	1/8	FHM-YZ1-NPT2-	0.96(24.4)	0.41(10.4)	0.34(8.6)	0.05(1.3)	0.31(7.9)	0.56(14.3)
1/8	1/8	FHM-YZ2-NPT2-	1.13(28.7)	0.41(10.4)	0.50(12.7)	0.09(2.3)	0.44(11.1)	0.56(14.3)
1/8	1/4	FHM-YZ2-NPT4-	1.32(33.5)	0.59(15.0)	0.50(12.7)	0.09(2.3)	0.44(11.1)	0.75(19.1)
3/16	1/8	FHM-YZ3-NPT2-	1.17(29.7)	0.41(10.4)	0.54(13.7)	0.12(3.0)	0.50(12.7)	0.56(14.3)
1/4	1/8	FHM-YZ4-NPT2-	1.23(31.2)	0.41(10.4)	0.60(15.2)	0.19(4.8)	0.56(14.3)	0.56(14.3)
1/4	1/4	FHM-YZ4-NPT4-	1.41(35.8)	0.59(15.0)	0.60(15.2)	0.19(4.8)	0.56(14.3)	0.75(19.1)
1/4	3/8	FHM-YZ4-NPT6-	1.48(37.6)	0.59(15.0)	0.60(15.2)	0.19(4.8)	0.56(14.3)	0.87(22.2)
1/4	1/2	FHM-YZ4-NPT8-	1.67(42.4)	0.78(19.8)	0.60(15.2)	16.3(4.8)	0.56(14.3)	1.06(27.0)
5/16	1/8	FHM-YZ5-NPT2-	1.26(32.0)	0.41(10.4)	0.64(16.3)	16.3(6.4)	0.63(15.9)	0.56(14.3)
5/16	1/4	FHM-YZ5-NPT4-	1.45(36.8)	0.59(15.0)	0.64(16.3)	0.25(6.4)	0.63(15.9)	0.75(19.1)
3/8	1/8	FHM-YZ6-NPT2-	1.29(32.8)	0.41(10.4)	0.66(16.8)	0.28(7.1)	0.69(17.5)	0.63(15.9)
3/8	1/4	FHM-YZ6-NPT4-	1.48(37.6)	0.59(15.0)	0.66(16.8)	0.28(7.1)	0.69(17.5)	0.75(19.1)
3/8	3/8	FHM-YZ6-NPT6-	1.54(39.1)	0.59(15.0)	0.66(16.8)	1.34(7.1)	0.69(17.5)	0.88(22.2)
3/8	1/2	FHM-YZ6-NPT8-	1.73(43.9)	0.78(19.8)	0.66(16.8)	0.28(7.1)	0.69(17.5)	1.06(27.0)
3/8	3/4	FHM-YZ6-NPT12-	1.88(47.8)	0.81(20.6)	0.66(16.8)	0.28(7.1)	0.69(17.5)	1.31(33.3)
1/2	1/4	FHM-YZ8-NPT4-	1.59(40.4)	0.59(15.0)	0.90(22.9)	0.41(10.4)	0.87(22.2)	0.81(20.6)
1/2	3/8	FHM-YZ8-NPT6-	1.65(41.9)	0.59(15.0)	0.90(22.9)	0.41(10.4)	0.87(22.2)	0.87(22.2)
1/2	1/2	FHM-YZ8-NPT8-	1.84(46.7)	0.78(19.8)	0.90(22.9)	0.41(10.4)	0.87(22.2)	1.06(27.0)
1/2	3/4	FHM-YZ8-NPT12-	1.90(48.3)	0.81(20.6)	0.90(22.9)	0.41(10.4)	0.87(22.2)	1.31(33.3)
5/8	3/8	FHM-YZ10-NPT6-	1.65(41.9)	0.59(15.0)	0.96(24.4)	0.50(12.7)	1.00(25.4)	0.94(23.8)
5/8	1/2	FHM-YZ10-NPT8-	1.84(46.7)	0.78(19.8)	0.96(24.4)	0.50(12.7)	1.00(25.4)	1.06(27.0)
3/4	1/2	FHM-YZ12-NPT8-	1.84(46.7)	0.78(19.8)	0.96(24.4)	0.62(15.7)	1.13(28.6)	1.06(27.0)
3/4	3/4	FHM-YZ12-NPT12-	1.90(48.3)	0.81(20.6)	0.96(24.4)	0.62(15.7)	1.13(28.6)	1.31(33.3)
7/8	3/4	FHM-YZ14-NPT12-	1.96(49.8)	0.81(20.6)	1.02(25.9)	0.72(18.3)	1.25(31.8)	1.31(33.3)
1	3/4	FHM-YZ16-NPT12-	2.10(53.3)	0.81(20.6)	1.23(31.2)	0.88(22.4)	1.50(38.1)	1.37(34.9)
1	1	FHM-YZ16-NPT16-	2.45(62.2)	1.00(25.4)	1.23(31.2)	0.88(22.4)	1.50(38.1)	1.63(41.3)
1 1/4	1 1/4	FHM-YZ20-NPT20-	2.94(74.7)	1.00(25.4)	1.62(41.1)	1.09(27.7)	1.87(47.6)	2.13(54.0)
1 1/2	1 1/2	FHM-YZ24-NPT24-	3.30(83.8)	1.09(27.7)	1.97(50.0)	1.34(34.0)	2.25(57.2)	2.37(60.3)

## Штуцер с внутренней резьбой

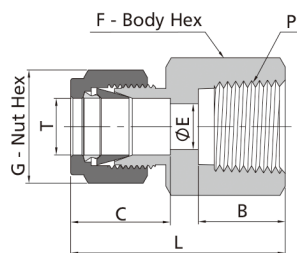

Дюймовая трубка			Коническая резьба ISO (RT)					
Т-Трубка (дюймы)	P-RT Размер резьбы	Артикул	Размеры, дюймы. (мм)					
			L	B	C	E	G	F
1/4	1/8	FHM-YZ4-RT2-	1.23(31.2)	0.41(10.4)	0.60(15.2)	0.19(4.8)	0.56(14.3)	0.56(14.3)
1/4	1/4	FHM-YZ4-RT4-	1.41(35.8)	0.59(15.0)	0.60(15.2)	0.19(4.8)	0.56(14.3)	0.75(19.1)
1/4	3/8	FHM-YZ4-RT6-	1.48(37.6)	0.59(15.0)	0.60(15.2)	0.19(4.8)	0.56(14.3)	0.87(22.2)
1/4	1/2	FHM-YZ4-RT8-	1.67(42.4)	0.78(19.8)	0.60(15.2)	0.19(4.8)	0.56(14.3)	1.06(27.0)
3/8	1/4	FHM-YZ6-RT4-	1.48(37.6)	0.59(15.0)	0.66(16.8)	0.28(7.1)	0.69(17.5)	0.75(19.1)
3/8	3/8	FHM-YZ6-RT6-	1.54(39.1)	0.59(15.0)	0.66(16.8)	0.28(7.1)	0.69(17.5)	0.87(22.2)
3/8	1/2	FHM-YZ6-RT8-	1.73(43.9)	0.78(19.8)	0.66(16.8)	0.28(7.1)	0.69(17.5)	1.06(27.0)
1/2	1/4	FHM-YZ8-RT 4-	1.59(40.4)	0.59(15.0)	0.90(22.9)	0.41(10.4)	0.87(22.2)	0.81(20.6)
1/2	3/8	FHM-YZ8-RT6-	1.65(41.9)	0.59(15.0)	0.90(22.9)	0.41(10.4)	0.87(22.2)	0.87(22.2)
1/2	1/2	FHM-YZ8-RT8-	1.84(46.7)	0.78(19.8)	0.90(22.9)	0.41(10.4)	0.87(22.2)	1.06(27.0)

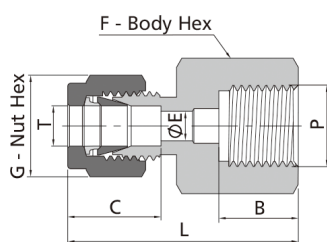

Дюймовая трубка			Цилиндрическая резьба ISO (RG)					
Т-Трубка (дюймы)	P-RG Размер резьбы	Артикул	Размеры, дюймы. (мм)					
			L	B	C	E	G	F
1/8	1/4	FHM-YZ2-RG4-	1.39(35.3)	0.51(12.9)	0.50(12.7)	0.09(2.3)	0.44(11.1)	0.75(19.1)
1/8	3/8	FHM-YZ2-RG6-	1.52(38.7)	0.56(14.2)	0.50(12.7)	0.09(2.3)	0.44(11.1)	0.94(23.8)
1/4	1/4	FHM-YZ4-RG4-	1.48(37.6)	0.51(12.9)	0.60(15.2)	0.19(4.8)	0.56(14.3)	0.75(19.1)
1/4	3/8	FHM-YZ4-RG6-	1.48(37.6)	0.56(14.2)	0.60(15.2)	0.19(4.8)	0.56(14.3)	0.94(23.8)
1/4	1/2	FHM-YZ4-RG8-	1.71(43.4)	0.74(18.8)	0.60(15.2)	0.19(4.8)	0.56(14.3)	1.06(27.0)
5/16	1/4	FHM-YZ5-RG4-	1.51(38.4)	0.51(12.9)	0.64(16.3)	0.22(5.6)	0.63(15.9)	0.75(19.1)
5/16	3/8	FHM-YZ5-RG6-	1.45(36.9)	0.56(14.2)	0.64(16.3)	0.25(6.4)	0.63(15.9)	0.94(23.8)
5/16	1/2	FHM-YZ5-RG8-	1.61(40.9)	0.74(18.8)	0.64(16.3)	0.28(7.1)	0.63(15.9)	1.06(27.0)
3/8	1/4	FHM-YZ6-RG4-	1.54(39.1)	0.51(12.9)	0.66(16.8)	0.22(5.6)	0.69(17.5)	0.75(19.1)
3/8	3/8	FHM-YZ6-RG6-	1.52(38.6)	0.56(14.2)	0.66(16.8)	0.25(6.4)	0.69(17.5)	0.94(23.8)
3/8	1/2	FHM-YZ6-RG8-	1.65(41.9)	0.74(18.8)	0.66(16.8)	0.28(7.1)	0.69(17.5)	1.06(27.0)
1/2	1/4	FHM-YZ8-RG4-	1.65(41.9)	0.51(12.9)	0.90(22.9)	0.22(5.6)	0.87(22.2)	0.87(22.2)
1/2	3/8	FHM-YZ8-RG6-	1.75(44.5)	0.56(14.2)	0.90(22.9)	0.25(6.4)	0.87(22.2)	0.94(23.8)
1/2	1/2	FHM-YZ8-RG8-	1.90(48.3)	0.74(18.8)	0.90(22.9)	0.28(7.1)	0.87(22.2)	1.06(27.0)

# Размеры

## Штуцер с внутренней резьбой

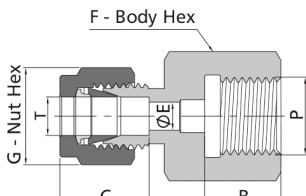

Адаптировано к японскому стандарту (JIS B7505)

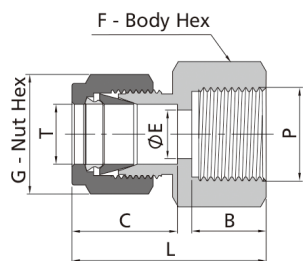

## Штуцер с внутренней резьбой

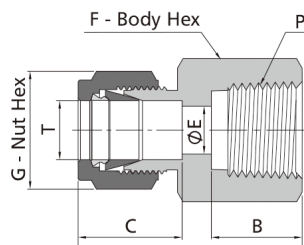

### Дюймовая трубка

### Цилиндрическая резьба ISO (RJ)

Т-Трубка (дюймы)	P-RJ Размер резьбы	Артикул	Размеры, дюймы. (мм)					
			L	B	C	E	G	F
1/4	1/4	FHM-YZ4-RJ4-	1.48(37.6)	0.51(12.9)	0.60(15.2)	0.18(4.6)	0.56(14.3)	0.75(19.1)
1/4	3/8	FHM-YZ4-RJ6-	1.48(37.6)	0.62(15.8)	0.60(15.2)	0.19(4.8)	0.56(14.3)	0.94(23.8)
1/4	1/2	FHM-YZ4-RJ8-	1.71(43.4)	0.74(18.8)	0.60(15.2)	0.19(4.8)	0.56(14.3)	1.06(27.0)
5/16	1/4	FHM-YZ5-RJ4-	1.51(38.4)	0.51(12.9)	0.64(16.3)	0.22(5.6)	0.63(15.9)	0.75(19.1)
5/16	1/2	FHM-YZ5-RJ8-	1.61(40.9)	0.74(18.8)	0.64(16.3)	0.28(7.1)	0.63(15.9)	1.06(27.0)
3/8	1/4	FHM-YZ6-RJ4-	1.54(39.1)	0.51(12.9)	0.66(16.8)	0.22(5.6)	0.69(17.5)	0.75(19.1)
3/8	3/8	FHM-YZ6-RJ6-	1.52(38.6)	0.62(15.8)	0.66(16.8)	0.25(6.4)	0.69(17.5)	0.94(23.8)
3/8	1/2	FHM-YZ6-RJ8-	1.65(41.9)	0.74(18.8)	0.66(16.8)	0.28(7.1)	0.69(17.5)	1.06(27.0)
1/2	1/4	FHM-YZ8-RJ4-	1.65(41.9)	0.51(12.9)	0.90(22.9)	0.22(5.6)	0.87(22.2)	0.81(20.6)
1/2	3/8	FHM-YZ8-RJ6-	1.75(44.5)	0.62(15.8)	0.90(22.9)	0.25(6.4)	0.87(22.2)	0.94(23.8)
1/2	1/2	FHM-YZ8-RJ8-	1.90(48.3)	0.74(18.8)	0.90(22.9)	0.28(7.1)	0.87(22.2)	1.06(27.0)

### Дюймовая трубка

### Метрическая резьба

Т-Трубка (дюймы)	P-Размер метрической резьбы	Артикул	Размеры, дюймы. (мм)					
			L	B	C	E	G	F
1/8	M14 × 1.5	FHM-YZ2-MS14-	1.22(31.0)	0.51(13.0)	0.50(12.7)	0.09(2.3)	0.44(11.1)	0.75(19.1)
1/8	M16 × 1.5	FHM-YZ2-MS16-	1.31(33.3)	0.55(14.0)	0.50(12.7)	0.09(2.3)	0.44(11.1)	0.87(22.2)
1/8	M18 × 1.5	FHM-YZ2-MS18-	1.35(34.3)	0.59(15.0)	0.50(12.7)	0.09(2.3)	0.44(11.1)	1.00(25.4)
1/8	M20 × 1.5	FHM-YZ2-MS20-	1.39(35.3)	0.63(16.0)	0.50(12.7)	0.09(2.3)	0.44(11.1)	1.06(27.0)
1/4	M16 × 1.5	FHM-YZ4-MS16-	1.41(35.8)	0.55(14.0)	0.60(15.2)	0.19(4.8)	0.56(14.3)	0.87(22.2)
1/4	M18 × 1.5	FHM-YZ4-MS18-	1.45(36.8)	0.59(15.0)	0.60(15.2)	0.19(4.8)	0.56(14.3)	1.00(25.4)
1/4	M20 × 1.5	FHM-YZ4-MS20-	1.49(37.8)	0.63(16.0)	0.60(15.2)	0.19(4.8)	0.56(14.3)	1.06(27.0)
3/8	M14 × 1.5	FHM-YZ6-MS14-	1.46(37.1)	0.51(13.0)	0.66(16.8)	0.28(7.1)	0.69(17.5)	0.75(19.1)
3/8	M16 × 1.5	FHM-YZ6-MS16-	1.48(37.5)	0.55(14.0)	0.66(16.8)	0.28(7.1)	0.69(17.5)	0.87(22.2)
3/8	M18 × 1.5	FHM-YZ6-MS18-	1.52(38.5)	0.59(15.0)	0.66(16.8)	0.28(7.1)	0.69(17.5)	1.00(25.4)
3/8	M20 × 1.5	FHM-YZ6-MS20-	1.56(39.5)	0.63(16.0)	0.66(16.8)	0.28(7.1)	0.69(17.5)	1.06(27.0)
1/2	M16 × 1.5	FHM-YZ8-MS16-	1.63(41.4)	0.55(14.0)	0.90(22.9)	0.33(8.4)	0.87(22.2)	0.87(22.2)
1/2	M18 × 1.5	FHM-YZ8-MS18-	1.67(42.4)	0.59(15.0)	0.90(22.9)	0.38(9.6)	0.87(22.2)	1.00(25.4)
1/2	M20 × 1.5	FHM-YZ8-MS20-	1.71(43.4)	0.63(16.0)	0.90(22.9)	0.41(10.4)	0.87(22.2)	1.06(27.0)
1/2	M22 × 1.5	FHM-YZ8-MS22-	1.65(41.9)	0.63(16.0)	0.90(22.9)	0.38(9.7)	0.87(22.2)	1.06(27.0)

### Метрическая трубка

### Резьба NPT

Т-Трубка (мм)	P-NPT Размер резьбы	Артикул	Размеры, дюймы. (мм)					
			L	B	C	E	G	F
3	1/8	FHM-GZ3-NPT2-	28.7(1.13)	10.4(0.41)	12.9(0.51)	2.4(0.09)	12.0(0.47)	14.0(0.55)
3	1/4	FHM-GZ3-NPT4-	33.5(1.32)	15.0(0.59)	12.9(0.51)	2.4(0.09)	12.0(0.47)	19.0(0.75)
4	1/8	FHM-GZ4-NPT2-	29.7(1.17)	10.4(0.41)	13.7(0.54)	2.4(0.09)	12.0(0.47)	14.0(0.55)
6	1/8	FHM-GZ6-NPT2-	31.3(1.23)	10.4(0.41)	15.3(0.60)	4.8(0.19)	14.0(0.55)	14.0(0.55)
6	1/4	FHM-GZ6-NPT4-	35.8(1.41)	15.0(0.59)	15.3(0.60)	4.8(0.19)	14.0(0.55)	19.0(0.75)
6	3/8	FHM-GZ6-NPT6-	37.7(1.48)	15.0(0.59)	15.3(0.60)	4.8(0.19)	14.0(0.55)	22.0(0.87)
6	1/2	FHM-GZ6-NPT8-	42.5(1.67)	19.8(0.78)	15.3(0.60)	4.8(0.19)	14.0(0.55)	27.0(1.06)
8	1/8	FHM-GZ8-NPT2-	32.1(1.26)	10.4(0.41)	16.2(0.64)	6.4(0.25)	16.0(0.63)	15.0(0.59)
8	1/4	FHM-GZ8-NPT4-	37.0(1.46)	15.0(0.59)	16.2(0.64)	6.4(0.25)	16.0(0.63)	19.0(0.75)
8	3/8	FHM-GZ8-NPT6-	38.5(1.52)	15.0(0.59)	16.2(0.64)	6.4(0.25)	16.0(0.63)	22.0(0.87)
8	1/2	FHM-GZ8-NPT8-	43.3(1.70)	19.8(0.78)	16.2(0.64)	6.4(0.25)	16.0(0.63)	27.0(1.06)
10	1/8	FHM-GZ10-NPT2-	33.0(1.30)	10.4(0.41)	17.2(0.68)	7.9(0.31)	19.0(0.75)	18.0(0.71)
10	1/4	FHM-GZ10-NPT4-	37.8(1.49)	15.0(0.59)	17.2(0.68)	7.9(0.31)	19.0(0.75)	19.0(0.75)
10	3/8	FHM-GZ10-NPT6-	39.4(1.55)	15.0(0.59)	17.2(0.68)	7.9(0.31)	19.0(0.75)	22.0(0.87)
10	1/2	FHM-GZ10-NPT8-	44.2(1.74)	19.8(0.78)	17.2(0.68)	7.9(0.31)	19.0(0.75)	27.0(1.06)

## Штуцер с внутренней резьбой

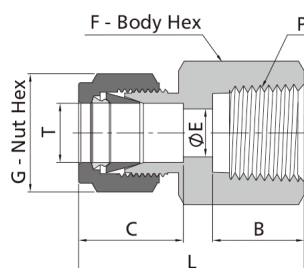
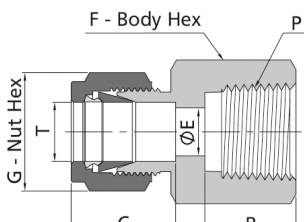

### Метрическая трубка Резьба NPT

Т-Трубка (мм.)	P-NPT Размер резьбы	Артикул	Размеры, дюймы. (мм)					
			L	B	C	E	G	F
12	1/4	FHM-GZ12-NPT4-	40.3(1.59)	15.0(0.59)	22.8(0.90)	9.5(0.37)	22.0(0.87)	22.0(0.87)
12	3/8	FHM-GZ12-NPT6-	41.9(1.65)	15.0(0.59)	22.8(0.90)	9.5(0.37)	22.0(0.87)	22.0(0.87)
12	1/2	FHM-GZ12-NPT8-	46.7(1.84)	19.8(0.78)	22.8(0.90)	9.5(0.37)	22.0(0.87)	27.0(1.06)
12	3/4	FHM-GZ12-NPT12-	49.1(1.93)	20.6(0.81)	22.8(0.90)	9.5(0.37)	22.0(0.87)	35.0(1.38)
14	3/4	FHM-GZ14-NPT12-	49.7(1.96)	20.6(0.81)	24.4(0.96)	11.1(0.44)	25.0(0.98)	35.0(1.38)
15	1/2	FHM-GZ15-NPT8-	46.7(1.84)	19.8(0.78)	24.4(0.96)	11.9(0.47)	25.0(0.98)	27.0(1.06)
16	3/8	FHM-GZ16-NPT6-	41.9(1.65)	15.0(0.59)	24.4(0.96)	12.7(0.50)	25.0(0.98)	27.0(1.06)
16	1/2	FHM-GZ16-NPT8-	46.9(1.85)	19.8(0.78)	24.4(0.96)	12.7(0.50)	25.0(0.98)	27.0(1.06)
20	1/2	FHM-GZ20-NPT8-	47.9(1.89)	19.8(0.78)	26.0(1.02)	15.9(0.63)	32.0(1.26)	30.0(1.18)
20	3/4	FHM-GZ20-NPT12-	49.7(1.96)	20.6(0.81)	26.0(1.02)	15.9(0.63)	32.0(1.26)	35.0(1.38)
22	3/4	FHM-GZ22-NPT12-	49.7(1.96)	20.6(0.81)	26.0(1.02)	18.3(0.72)	32.0(1.26)	35.0(1.38)
22	1	FHM-GZ22-N PT16-	57.9(2.28)	25.4(1.00)	26.0(1.02)	18.3(0.72)	32.0(1.26)	41.0(1.61)
25	3/4	FHM-GZ25-NPT12-	53.4(2.10)	20.6(0.81)	31.3(1.23)	21.8(0.86)	38.0(1.50)	35.0(1.38)
25	1	FHM-GZ25-NPT16-	62.3(2.45)	25.4(1.00)	31.3(1.23)	21.8(0.86)	38.0(1.50)	41.0(1.61)

### Метрическая трубка Коническая резьба ISO (RT)

Т-Трубка (мм.)	P-RT Размер резьбы	Артикул	Размеры, дюймы. (мм)					
			L	B	C	E	G	F
3	1/8	FHM-GZ3-RT2-	28.7(1.13)	10.4(0.41)	12.9(0.51)	2.4(0.09)	12.0(0.47)	14.0(0.55)
6	1/8	FHM-GZ6-RT2-	31.3(1.23)	10.4(0.41)	15.3(0.60)	4.8(0.19)	14.0(0.55)	14.0(0.55)
6	1/4	FHM-GZ6-RT4-	35.8(1.41)	15.0(0.59)	15.3(0.60)	4.8(0.19)	14.0(0.55)	19.0(0.75)
6	3/8	FHM-GZ6-RT6-	37.9(1.49)	15.0(0.59)	15.3(0.60)	4.8(0.19)	14.0(0.55)	22.0(0.87)
6	1/2	FHM-GZ6-RT8-	42.5(1.67)	19.8(0.78)	15.3(0.60)	4.8(0.19)	14.0(0.55)	27.0(1.06)
8	1/8	FHM-GZ8-RT2-	32.1(1.26)	10.4(0.41)	16.2(0.64)	6.4(0.25)	16.0(0.63)	15.0(0.59)
8	1/4	FHM-GZ8-RT4-	37.0(1.46)	15.0(0.59)	16.2(0.64)	6.4(0.25)	16.0(0.63)	19.0(0.75)
8	3/8	FHM-GZ8-RT6-	38.5(1.52)	15.0(0.59)	16.2(0.64)	6.4(0.25)	16.0(0.63)	22.0(0.87)
8	1/2	FHM-GZ8-RT8-	43.3(1.70)	19.8(0.78)	16.2(0.64)	6.4(0.25)	16.0(0.63)	27.0(1.06)
10	1/8	FHM-GZ10-RT2-	33.0(1.30)	10.4(0.41)	17.2(0.68)	7.9(0.31)	19.0(0.75)	18.0(0.71)
10	1/4	FHM-GZ10-RT4-	37.8(1.49)	15.0(0.59)	17.2(0.68)	7.9(0.31)	19.0(0.75)	19.0(0.75)
10	3/8	FHM-GZ10-RT6-	39.4(1.55)	15.0(0.59)	17.2(0.68)	7.9(0.31)	19.0(0.75)	22.0(0.87)
10	1/2	FHM-GZ10-RT8-	44.2(1.74)	19.8(0.78)	17.2(0.68)	7.9(0.31)	19.0(0.75)	27.0(1.06)
12	1/8	FHM-GZ12-RT2-	35.5(1.40)	10.4(0.41)	22.8(0.90)	8.3(0.33)	22.0(0.87)	22.0(0.87)
12	1/4	FHM-GZ12-RT4-	40.3(1.59)	15.0(0.59)	22.8(0.90)	9.5(0.37)	22.0(0.87)	22.0(0.87)
12	3/8	FHM-GZ12-RT6-	41.9(1.65)	15.0(0.59)	22.8(0.90)	9.5(0.37)	22.0(0.87)	22.0(0.87)
12	1/2	FHM-GZ12-RT8-	46.7(1.84)	19.8(0.78)	22.8(0.90)	9.5(0.37)	22.0(0.87)	27.0(1.06)
12	3/4	FHM-GZ12-RT12-	49.0(1.93)	20.6(0.81)	22.8(0.90)	9.5(0.37)	22.0(0.87)	35.0(1.38)
15	1/2	FHM-GZ15-RT8-	46.7(1.84)	19.8(0.78)	24.4(0.96)	11.9(0.47)	25.0(0.98)	27.0(1.06)
16	1/2	FHM-GZ16-RT8-	48.4(1.91)	19.8(0.78)	24.4(0.96)	12.7(0.50)	25.0(0.98)	27.0(1.06)
16	3/4	FHM-GZ16-RT12-	49.7(1.96)	20.6(0.81)	24.4(0.96)	12.7(0.50)	25.0(0.98)	35.0(1.38)
20	1/2	FHM-GZ20-RT8-	47.9(1.89)	19.8(0.78)	26.0(1.02)	15.9(0.63)	32.0(1.26)	30.0(1.18)
20	3/4	FHM-GZ20-RT12-	49.7(1.96)	20.6(0.81)	26.0(1.02)	15.9(0.63)	32.0(1.26)	35.0(1.38)
22	3/4	FHM-GZ22-RT12-	49.7(1.96)	20.6(0.81)	26.0(1.02)	18.3(0.72)	32.0(1.26)	35.0(1.38)
22	1	FHM-GZ22-RT16-	57.9(2.28)	25.4(1.00)	26.0(1.02)	18.3(0.72)	32.0(1.26)	41.0(1.61)
25	3/4	FHM-GZ25-RT12-	53.4(2.10)	20.6(0.81)	31.3(1.23)	21.8(0.86)	38.0(1.50)	35.0(1.38)
25	1	FHM-GZ25-RT16-	62.3(2.45)	25.4(1.00)	31.3(1.23)	21.8(0.86)	38.0(1.50)	41.0(1.61)

# Размеры

## Штуцер с внутренней резьбой

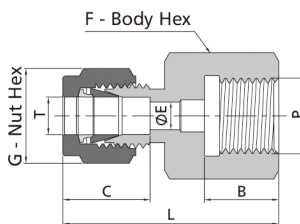
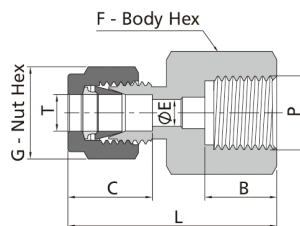
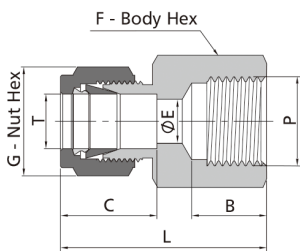

Адаптировано к японскому стандарту (JIS B7505)

### Метрическая резьба Цилиндрическая резьба ISO (RP)

Т-Трубка (мм)	P-RP Размер резьбы	Артикул	Размеры, дюймы. (мм)					
			L	B	C	E	G	F
6	1/8	FHM-GZ6-RP2-	33.5(1.32)	15.5(0.61)	15.3(0.60)	4.8(0.19)	14.0(0.55)	14.0(0.55)
6	1/4	FHM-GZ6-RP4-	39.4(1.55)	15.5(0.61)	15.3(0.60)	4.8(0.19)	14.0(0.55)	19.0(0.75)
22	3/4	FHM-GZ22-RP12-	53.3(2.10)	20.5(0.81)	26.0(1.02)	18.3(0.72)	32.0(1.26)	35.0(1.38)
25	1	FHM-GZ25-RP16-	63.9(2.52)	23.5(0.93)	31.3(1.23)	21.8(0.86)	38.0(1.50)	40.0(1.57)

### Метрическая трубка Цилиндрическая резьба ISO (RG)

Т-Трубка (мм.)	P-RG Размер резьбы	Артикул	Размеры, дюймы. (мм)					
			L	B	C	E	G	F
3	1/4	FHM-GZ3-RG4-	35.3(1.39)	12.9(0.51)	12.9(0.51)	2.4(0.09)	12.0(0.47)	19.0(0.75)
6	1/4	FHM-GZ6-RG4-	37.6(1.48)	12.9(0.51)	15.3(0.60)	4.8(0.19)	14.0(0.55)	19.0(0.75)
6	3/8	FHM-GZ6-RG6-	37.6(1.48)	14.2(0.56)	15.3(0.60)	4.8(0.19)	14.0(0.55)	24.0(0.94)
6	1/2	FHM-GZ6-RG8-	43.5(1.71)	18.8(0.74)	15.3(0.60)	4.8(0.19)	14.0(0.55)	27.0(1.06)
8	1/4	FHM-GZ8-RG4-	38.5(1.52)	12.9(0.51)	16.2(0.64)	5.5(0.22)	16.0(0.63)	19.0(0.75)
8	3/8	FHM-GZ8-RG6-	36.2(1.43)	14.2(0.56)	16.2(0.64)	6.4(0.25)	16.0(0.63)	24.0(0.94)
8	1/2	FHM-GZ8-RG8-	41.0(1.61)	18.8(0.74)	16.2(0.64)	6.4(0.25)	16.0(0.63)	27.0(1.06)
10	1/4	FHM-GZ10-RG4-	39.4(1.55)	12.9(0.51)	17.2(0.68)	5.5(0.22)	19.0(0.75)	19.0(0.75)
10	3/8	FHM-GZ10-RG6-	38.8(1.53)	14.2(0.56)	17.2(0.68)	6.4(0.25)	19.0(0.75)	24.0(0.94)
10	1/2	FHM-GZ10-RG8-	42.1(1.66)	18.8(0.74)	17.2(0.68)	7.9(0.31)	19.0(0.75)	27.0(1.06)
12	1/4	FHM-GZ12-RG4-	41.9(1.65)	12.9(0.51)	22.8(0.90)	5.5(0.22)	22.0(0.87)	22.0(0.87)
12	3/8	FHM-GZ12-RG6-	44.4(1.75)	14.2(0.56)	22.8(0.90)	6.4(0.25)	22.0(0.87)	24.0(0.94)
12	1/2	FHM-GZ12-RG8-	48.2(1.90)	18.8(0.74)	22.8(0.90)	7.1(0.28)	22.0(0.87)	27.0(1.06)
20	1/2	FHM-GZ20-RG8-	54.3(2.14)	18.8(0.74)	26.0(1.02)	7.1(0.28)	32.0(1.26)	30.0(1.18)
22	1/2	FHM-GZ22-RG8-	54.3(2.14)	18.8(0.74)	26.0(1.02)	7.1(0.28)	32.0(1.26)	30.0(1.18)

### Метрическая трубка Цилиндрическая резьба ISO (RJ)

Т-Трубка (мм.)	P-RJ Размер резьбы	Артикул	Размеры, дюймы. (мм)					
			L	B	C	E	G	F
6	1/4	FHM-GZ6-RJ4-	37.6(1.48)	12.9(0.51)	15.3(0.60)	4.8(0.19)	14.0(0.55)	19.0(0.75)
6	3/8	FHM-GZ6-RJ6-	37.6(1.48)	15.8(0.62)	15.3(0.60)	4.8(0.19)	14.0(0.55)	24.0(0.94)
6	1/2	FHM-GZ6-RJ8-	43.5(1.71)	18.8(0.74)	15.3(0.60)	4.8(0.19)	14.0(0.55)	27.0(1.06)
8	1/4	FHM-GZ8-RJ4-	38.5(1.52)	12.9(0.51)	16.2(0.64)	5.5(0.22)	16.0(0.63)	19.0(0.75)
8	3/8	FHM-GZ8-RJ6-	36.2(1.43)	15.8(0.62)	16.2(0.64)	6.5(0.26)	16.0(0.63)	24.0(0.94)
8	1/2	FHM-GZ8-RJ8-	41.0(1.61)	18.8(0.74)	16.2(0.64)	7.0(0.28)	16.0(0.63)	27.0(1.06)
10	1/4	FHM-GZ10-RJ4-	39.4(1.55)	12.9(0.51)	17.2(0.68)	5.5(0.22)	19.0(0.75)	19.0(0.75)
10	3/8	FHM-GZ10-RJ6-	38.8(1.53)	15.8(0.62)	17.2(0.68)	6.5(0.26)	19.0(0.75)	24.0(0.94)
10	1/2	FHM-GZ10-RJ8-	42.1(1.66)	18.8(0.74)	17.2(0.68)	7.0(0.28)	19.0(0.75)	27.0(1.06)
12	1/4	FHM-GZ12-RJ4-	41.9(1.65)	12.9(0.51)	22.8(0.90)	5.5(0.22)	22.0(0.87)	22.0(0.87)
12	3/8	FHM-GZ12-RJ6-	44.4(1.75)	15.8(0.62)	22.8(0.90)	6.5(0.26)	22.0(0.87)	24.0(0.94)
12	1/2	FHM-GZ12-RJ8-	48.2(1.90)	18.8(0.74)	22.8(0.90)	7.0(0.28)	22.0(0.87)	27.0(1.06)



## Штуцер с внутренней резьбой

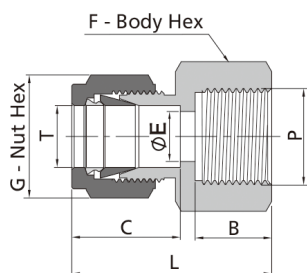

### Метрическая трубка

### Метрическая резьба

Т-Трубка (мм.)	Р-Размер метрической резьбы	Артикул	Размеры, дюймы. (мм)					
			L	B	C	E	G	F
6	M10 × 1	FHM-GZ6-MS10-	32.7(1.29)	11.0(0.43)	15.3(0.60)	4.7(0.19)	14.0(0.55)	16.0(0.63)
6	M14×1.5	FHM-GZ6-MS14-	36.1(1.42)	13.0(0.51)	15.3(0.60)	4.8(0.19)	14.0(0.55)	19.0(0.75)
6	M20 × 1.5	FHM-GZ6-MS20-	37.7(1.48)	16.0(0.63)	15.3(0.60)	4.8(0.19)	14.0(0.55)	27.0(1.06)
8	M8 × 1	FHM-GZ8-MS8-	31.6(1.24)	9.0(0.35)	16.2(0.64)	3.0(0.12)	16.0(0.63)	14.0(0.55)
8	M10 × 1	FHM-GZ8-MS10-	33.6(1.32)	11.0(0.43)	16.2(0.64)	4.0(0.16)	16.0(0.63)	16.0(0.63)
8	M14 × 1.5	FHM-GZ8-MS14-	35.6(1.40)	13.0(0.51)	16.2(0.64)	6.4(0.25)	16.0(0.63)	19.0(0.75)
8	M20 × 1.5	FHM-GZ8-MS20-	38.6(1.52)	16.0(0.63)	16.2(0.64)	6.4(0.25)	16.0(0.63)	27.0(1.06)
10	M16 × 1.5	FHM-GZ10-MS16-	38.1(1.50)	14.0(0.55)	17.2(0.68)	7.9(0.31)	19.0(0.75)	22.0(0.87)
12	M20 × 1.5	FHM-GZ12-MS20-	44.9(1.77)	16.0(0.63)	22.8(0.90)	9.5(0.37)	22.0(0.87)	27.0(1.06)
14	M10 × 1	FHM-GZ14-MS10-	42.5(1.67)	11.0(0.43)	24.4(0.96)	4.0(0.16)	25.0(0.98)	24.0(0.94)
14	M20 × 1.5	FHM-GZ14-MS20-	44.9(1.77)	16.0(0.63)	24.4(0.96)	10.8(0.43)	25.0(0.98)	27.0(1.06)
14	M22 × 1.5	FHM-GZ14-MS22-	45.9(1.81)	17.0(0.67)	24.4(0.96)	11.1(0.44)	25.0(0.98)	27.0(1.06)
16	M20 × 1.5	FHM-GZ16-MS20-	44.9(1.77)	16.0(0.63)	24.4(0.96)	10.8(0.43)	25.0(0.98)	27.0(1.06)
20	M20 × 1.5	FHM-GZ20-MS20-	46.5(1.83)	16.0(0.63)	26.0(1.02)	10.8(0.43)	32.0(1.26)	30.0(1.18)
25	M27 × 2	FHM-GZ25-MS27-	54.4(2.14)	18.0(0.71)	31.3(1.23)	16.1(0.63)	38.0(1.50)	35.0(1.38)

## Штуцер с внутренней резьбой и монтажной гайкой

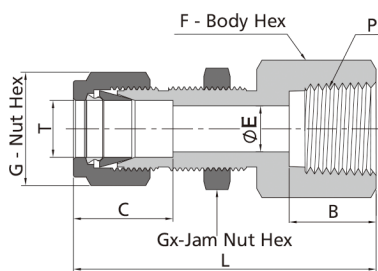

### Дюймовая трубка

### Резьба NPT

Т-Трубка (дюймы)	Р-NPT Размер резьбы	Артикул	Размеры, дюймы. ( )							Размер отверстия в панели дюймы. (мм)	Макс толщина панели дюймы. (мм)
			L	B	C	E	G	F	Gx		
1/16	1/16	FHMN-YZ1-NPT1-	1.19(30.2)	0.39(9.9)	0.34(8.6)	0.05(1.3)	0.31(7.9)	0.44(11.1)	0.31(7.9)	0.20(5.2)	0.13(3.2)
1/16	1/8	FHMN-YZ1-NPT2-	1.20(30.7)	0.41(10.4)	0.34(8.6)	0.05(1.3)	0.31(7.9)	0.56(14.3)	0.31(7.9)	0.20(5.2)	0.13(3.2)
1/8	1/8	FHMN-YZ2-NPT2-	1.76(44.7)	0.41(10.4)	0.50(12.7)	0.09(2.3)	0.44(11.1)	0.56(14.3)	0.50(12.7)	0.33(8.3)	0.50(12.7)
1/8	1/4	FHMN-YZ2-NPT4-	1.95(49.6)	0.59(15.0)	0.50(12.7)	0.09(2.3)	0.44(11.1)	0.75(19.1)	0.50(12.7)	0.33(8.3)	0.50(12.7)
3/16	1/8	FHMN-YZ3-NPT2-	1.79(45.5)	0.41(10.4)	0.54(13.7)	0.12(3.0)	0.50(12.7)	0.56(14.3)	0.56(14.3)	0.39(9.9)	0.50(12.7)
1/4	1/8	FHMN-YZ4-NPT2-	1.85(47.0)	0.41(10.4)	0.60(15.2)	0.19(4.8)	0.56(14.3)	0.63(15.9)	0.63(15.9)	0.45(11.5)	0.40(10.2)
1/4	1/4	FHMN-YZ4-NPT4-	2.04(51.8)	0.59(15.0)	0.60(15.2)	0.19(4.8)	0.56(14.3)	0.75(19.1)	0.63(15.9)	0.45(11.5)	0.40(10.2)
1/4	3/8	FHMN-YZ4-NPT6-	2.10(53.3)	0.59(15.0)	0.60(15.2)	0.19(4.8)	0.56(14.3)	0.87(22.2)	0.63(15.9)	0.45(11.5)	0.40(10.2)
1/4	1/2	FHMN-YZ4-NPT8-	2.29(58.2)	0.78(19.8)	0.60(15.2)	0.19(4.8)	0.56(14.3)	1.06(27.0)	0.63(15.9)	0.45(11.5)	0.40(10.2)
5/16	1/8	FHMN-YZ5-NPT2-	1.96(49.8)	0.41(10.4)	0.64(16.3)	0.25(6.4)	0.63(15.9)	0.69(17.5)	0.69(17.5)	0.52(13.1)	0.44(11.2)
5/16	1/4	FHMN-YZ5-NPT4-	2.3(60.5)	0.59(15.0)	0.64(16.3)	0.25(6.4)	0.63(15.9)	0.75(19.1)	0.69(17.5)	0.52(13.1)	0.44(11.2)
3/8	1/8	FHMN-YZ6-NPT2-	1.98(50.3)	0.41(10.4)	0.66(16.8)	0.28(7.1)	0.69(17.5)	0.75(19.1)	0.75(19.1)	0.58(14.7)	0.44(11.2)
3/8	1/4	FHMN-YZ6-NPT4-	2.17(55.1)	0.59(15.0)	0.66(16.8)	0.28(7.1)	0.69(17.5)	0.75(19.1)	0.75(19.1)	0.58(14.7)	0.44(11.2)
3/8	3/8	FHMN-YZ6-NPT6-	2.23(56.6)	0.59(15.0)	0.66(16.8)	0.28(7.1)	0.69(17.5)	0.87(22.2)	0.75(19.1)	0.58(14.7)	0.44(11.2)
3/8	1/2	FHMN-YZ6-NPT8-	2.42(61.5)	0.78(19.8)	0.66(16.8)	0.28(7.1)	0.69(17.5)	1.06(27.0)	0.75(19.1)	0.58(14.7)	0.44(11.2)
3/8	3/4	FHMN-YZ6-NPT12-	2.57(65.3)	0.81(20.6)	0.66(16.8)	0.28(7.1)	0.69(17.5)	1.31(33.3)	0.75(19.1)	0.58(14.7)	0.44(11.2)
1/2	1/4	FHMN-YZ8-NPT4-	2.37(60.2)	0.59(15.0)	0.90(22.9)	0.41(10.4)	0.87(22.2)	0.94(23.8)	0.94(23.8)	0.76(19.4)	0.50(12.7)
1/2	3/8	FHMN-YZ8-NPT6-	2.43(61.7)	0.59(15.0)	0.90(22.9)	0.41(10.4)	0.87(22.2)	0.94(23.8)	0.94(23.8)	0.76(19.4)	0.50(12.7)
1/2	1/2	FHMN-YZ8-NPT8-	2.62(66.5)	0.78(19.8)	0.90(22.9)	0.41(10.4)	0.87(22.2)	1.06(27.0)	0.94(23.8)	0.76(19.4)	0.50(12.7)
1/2	3/4	FHMN-YZ8-NPT12-	2.68(68.1)	0.81(20.6)	0.90(22.9)	0.41(10.4)	0.87(22.2)	1.31(33.3)	0.94(23.8)	0.76(19.4)	0.50(12.7)

# Размеры

## Штуцер с внутренней резьбой и монтажной гайкой

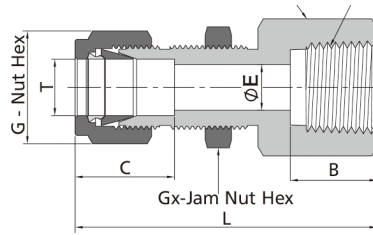

### Дюймовая трубка

### Резьба NPT

Т-Трубка (дюймы)	P-NPT Размер резьбы	Артикул	Размеры, дюймы. ( )							Размер отверстия в панели дюймы. (мм)	Макс толщина панели дюймы. (мм)
			L	B	C	E	G	F	Gx		
5/8	3/8	FHMN-YZ10-NPT6-	2.46(62.5)	0.59(15.0)	0.96(24.4)	0.50(12.7)	1.00(25.4)	1.06(27.0)	1.06(27.0)	0.89(22.6)	0.59(15.1)
5/8	1/2	FHMN-YZ10-NPT8-	2.65(67.3)	0.78(19.8)	0.96(24.4)	0.50(12.7)	1.00(25.4)	1.06(27.0)	1.06(27.0)	0.89(22.6)	0.59(15.1)
3/4	1/2	FHMN-YZ12-NPT8-	2.84(72.2)	0.78(19.8)	0.96(24.4)	0.62(15.7)	1.13(28.6)	1.19(30.2)	1.19(30.2)	1.02(25.8)	0.78(19.8)
3/4	3/4	FHMN-YZ12-NPT12-	2.90(73.7)	0.81(20.6)	0.96(24.4)	0.62(15.7)	1.13(28.6)	1.31(33.3)	1.19(30.2)	1.02(25.8)	0.78(19.8)
7/8	3/4	FHMN-YZ14-NPT12-	3.18(80.8)	0.81(20.6)	1.02(25.9)	0.72(18.3)	1.25(31.8)	1.31(33.3)	1.31(33.3)	1.14(29.0)	0.94(23.8)
1	3/4	FHMN-YZ16-NPT12-	3.33(84.7)	0.81(20.6)	1.23(31.2)	0.88(22.4)	1.50(38.1)	1.63(41.3)	1.63(41.3)	1.33(33.7)	0.94(23.8)
1	1	FHMN-YZ16-NPT16-	3.68(93.5)	1.00(25.4)	1.23(31.2)	0.88(22.4)	1.50(38.1)	1.63(41.3)	1.63(41.3)	1.33(33.7)	0.94(23.8)

### Метрическая трубка

### Резьба NPT

Т-Трубка (мм.)	P-NPT Размер резьбы	Артикул	Размеры, дюймы. ( )							Размер отверстия в панели дюймы. (мм)	Макс толщина панели дюймы. (мм)
			L	B	C	E	G	F	Gx		
6	1/8	FHMN-GZ6-NPT2-	47.2(1.86)	10.4(0.41)	15.3(0.60)	4.8(0.19)	14.0(0.55)	16.0(0.63)	16.0(0.63)	11.5(0.45)	10.2(0.40)
6	1/4	FHMN-GZ6-NPT4-	51.8(2.04)	15.0(0.59)	15.3(0.60)	4.8(0.19)	14.0(0.55)	19.0(0.75)	16.0(0.63)	11.5(0.45)	10.2(0.40)
8	1/8	FHMN-GZ8-NPT2-	49.6(1.95)	10.4(0.41)	16.2(0.64)	6.4(0.25)	16.0(0.63)	18.0(0.71)	18.0(0.71)	13.1(0.52)	11.2(0.44)
10	1/4	FHMN-GZ10-NPT4-	55.2(2.17)	15.0(0.59)	17.2(0.68)	7.9(0.31)	19.0(0.75)	22.0(0.87)	22.0(0.87)	16.3(0.64)	11.2(0.44)
12	3/8	FHMN-GZ12-NPT6-	62.9(2.48)	15.0(0.59)	22.8(0.90)	9.5(0.37)	22.0(0.87)	24.0(0.94)	24.0(0.94)	19.5(0.77)	12.7(0.50)
12	1/2	FHMN-GZ12-NPT8-	66.5(2.62)	19.8(0.78)	22.8(0.90)	9.5(0.37)	22.0(0.87)	27.0(1.06)	24.0(0.94)	19.5(0.77)	12.7(0.50)
1	1	FHMN-YZ16-NPT16-	3.68(93.5)	1.00(25.4)	1.23(31.2)	0.88(22.4)	1.50(38.1)	1.63(41.3)	1.63(41.3)	1.33(33.7)	0.94(23.8)

## Муфта проходная

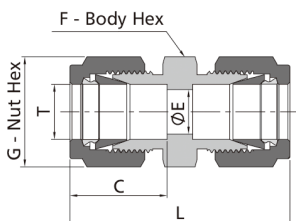

### Дюймовая трубка

Т-Трубка (дюймы)	Артикул	размеры, дюймы. (мм)				
		L	C	G	F	E
1/16	FUP-YZ1-	0.99(25.1)	0.34(8.6)	0.31(7.9)	0.31(7.9)	0.05(1.3)
1/8	FUP-YZ2-	1.40(35.6)	0.50(12.7)	0.44(11.1)	0.44(11.1)	0.09(2.3)
3/16	FUP-YZ1-	1.47(37.3)	0.54(13.7)	0.50(12.7)	0.50(12.7)	0.12(3.0)
1/4	FUP-YZ4-	1.61(40.9)	0.60(15.2)	0.56(14.3)	0.50(12.7)	0.19(4.8)
5/16	FUP-YZ5-	1.69(42.9)	0.64(16.2)	0.63(15.9)	0.56(14.3)	0.25(6.4)
3/8	FUP-YZ6-	1.77(45.0)	0.66(16.8)	0.69(17.5)	0.63(15.9)	0.28(7.1)
1/2	FUP-YZ8-	2.02(51.3)	0.90(22.9)	0.87(22.2)	0.81(20.6)	0.41(10.4)
5/8	FUP-YZ10-	2.05(52.1)	0.96(24.4)	1.00(25.4)	0.94(23.9)	0.50(12.7)
3/4	FUP-YZ12-	2.11(53.6)	0.96(24.4)	1.13(28.6)	1.06(27.0)	0.62(15.7)
7/8	FUP-YZ14-	2.19(55.7)	1.02(25.9)	1.25(31.8)	1.19(30.2)	0.72(18.3)
1	FUP-YZ16-	2.55(64.8)	1.23(31.2)	1.5(38.1)	1.37(34.9)	0.88(22.4)
1 1/8	FUP-YZ18-	3.47(88.2)	1.44(36.7)	1.75(44.5)	1.63(41.3)	0.97(24.6)
1 1/4	FUP-YZ20-	3.63(92.2)	1.62(41.1)	1.87(47.6)	1.75(44.5)	1.09(27.7)
1 1/2	FUP-YZ24-	4.25(108.0)	1.97(50.0)	2.25(57.2)	2.13(54.0)	1.34(34.0)

## Муфта проходная

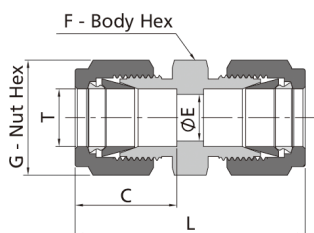

### Метрическая трубка

Т-Трубка (мм.)	Артикул	Размеры, дюймы. (мм)				
		L	C	G	F	E
2	FUP-GZ2-	35.6(1.40)	12.9(0.51)	12.0(0.47)	12.0(0.47)	1.7(0.07)
3	FUP-GZ3-	35.3(1.39)	12.9(0.51)	12.0(0.47)	12.0(0.47)	2.4(0.09)
4	FUP-GZ4-	37.3(1.47)	13.7(0.54)	12.0(0.47)	12.0(0.47)	2.4(0.09)
6	FUP-GZ6-	41.0(1.61)	15.3(0.60)	14.0(0.55)	14.0(0.55)	4.8(0.19)
8	FUP-GZ8-	43.2(1.70)	16.2(0.64)	16.0(0.63)	15.0(0.59)	6.4(0.25)
10	FUP-GZ10-	46.2(1.82)	17.2(0.68)	19.0(0.75)	18.0(0.71)	7.9(0.31)
12	FUP-GZ12-	51.2(2.02)	22.8(0.90)	22.0(0.87)	22.0(0.87)	9.5(0.37)
14	FUP-GZ14-	52.0(2.05)	24.4(0.96)	25.0(0.98)	24.0(0.94)	11.1(0.44)
15	FUP-GZ15-	52.0(2.05)	24.4(0.96)	25.0(0.98)	24.0(0.94)	11.9(0.47)
16	FUP-GZ16-	52.0(2.05)	24.4(0.96)	25.0(0.98)	24.0(0.94)	12.7(0.50)
18	FUP-GZ18-	53.5(2.11)	24.4(0.96)	30.0(1.18)	27.0(1.06)	15.1(0.59)
20	FUP-GZ20-	55.0(2.17)	26.0(1.02)	32.0(1.26)	30.0(1.18)	15.9(0.63)
22	FUP-GZ22-	55.0(2.17)	26.0(1.02)	32.0(1.26)	30.0(1.18)	18.3(0.72)
25	FUP-GZ25-	65.0(2.56)	31.3(1.23)	38.0(1.50)	35.0(1.38)	21.8(0.86)
28	FUP-GZ28-	85.0(3.35)	36.6(1.44)	46.0(1.81)	41.0(1.61)	21.8(0.86)
30	FUP-GZ30-	92.7(3.65)	39.6(1.56)	50.0(1.97)	46.0(1.81)	26.2(1.03)
32	FUP-GZ32-	97.3(3.83)	42.0(1.65)	50.0(1.97)	46.0(1.81)	28.6(1.13)
38	FUP-GZ38-	113.6(4.47)	49.4(1.94)	60.0(2.36)	55.0(2.17)	33.7(1.33)

## Муфта переходная

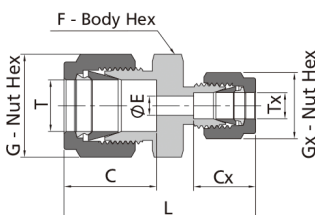

### Дюймовая трубка

Т-Трубка (дюймы.)	Тх-Трубка (мм.)	Артикул	Размеры, дюймы. (мм)						
			L	C	G	F	E	Cx	Gx
1/8	3	FUR-YZ2-GZ3-	1.39(35.2)	0.50(12.7)	0.44(11.1)	0.47(12.0)	0.09(2.3)	0.51(12.9)	0.47(12.0)
1/4	4	FUR-YZ4-GZ4-	1.55(39.4)	0.60(15.2)	0.56(14.3)	0.55(14.0)	0.09(2.4)	0.54(13.7)	0.47(12.0)
1/4	6	FUR-YZ4-GZ6-	1.62(41.2)	0.60(15.2)	0.56(14.3)	0.55(14.0)	0.19(4.8)	0.60(15.3)	0.55(14.0)
3/8	6	FUR-YZ6-GZ6-	1.72(43.7)	0.66(16.8)	0.69(17.5)	0.63(16.0)	0.19(4.8)	0.60(15.3)	0.55(14.0)
3/8	8	FUR-YZ6-GZ8-	1.75(44.5)	0.66(16.8)	0.69(17.5)	0.63(16.0)	0.25(6.4)	0.64(16.2)	0.63(16.0)
1/2	6	FUR-YZ8-GZ6-	1.88(47.7)	0.90(22.9)	0.87(22.2)	0.87(22.0)	0.19(4.8)	0.60(15.3)	0.55(14.0)
1/2	10	FUR-YZ8-GZ10-	1.93(48.9)	0.90(22.9)	0.87(22.2)	0.87(22.0)	0.31(7.9)	0.68(17.2)	0.75(19.0)
1/2	12	FUR-YZ8-GZ12-	2.02(51.4)	0.90(22.9)	0.87(22.2)	0.87(22.0)	0.37(9.5)	0.90(22.8)	0.87(22.0)
3/4	12	FUR-YZ12-GZ12-	2.13(54.2)	0.96(24.4)	1.13(28.6)	1.06(27.0)	0.37(9.5)	0.90(22.8)	0.87(22.0)
3/4	16	FUR-YZ12-GZ16-	2.12(53.9)	0.96(24.4)	1.13(28.6)	1.06(27.0)	0.50(12.7)	0.96(24.4)	0.98(25.0)
3/4	18	FUR-YZ12-GZ18-	2.11(53.6)	0.96(24.4)	1.13(28.6)	1.06(27.0)	0.59(15.1)	0.96(24.4)	1.18(30.0)
1	25	FUR-YZ16-GZ25-	2.65(67.4)	1.23(31.2)	1.50(38.1)	1.38(35.0)	0.86(21.8)	1.23(31.3)	1.50(38.0)

### Метрическая трубка

### Дюймовая трубка

T-Tube O.D. (in.)	Тх-Tube O.D. (mm)	Basic Ordering Number	Размеры, дюймы. (мм)						
			L	C	G	F	E	Cx	Gx
4	1/8	FUR-GZ4-YZ2-	36.5(1.44)	13.7(0.54)	12.0(0.47)	12.0(0.47)	2.4(0.09)	12.7(0.50)	11.1(0.44)
6	1/8	FUR-GZ6-YZ2-	38.5(1.52)	15.3(0.60)	14.0(0.55)	14.0(0.55)	2.4(0.09)	12.7(0.50)	11.1(0.44)
8	1/4	FUR-GZ8-YZ4-	42.3(1.67)	16.2(0.64)	16.0(0.63)	15.0(0.59)	4.8(0.19)	15.2(0.60)	14.3(0.56)
10	1/8	FUR-GZ10-YZ2-	41.8(1.65)	17.2(0.68)	19.0(0.75)	18.0(0.71)	2.4(0.09)	12.7(0.50)	11.1(0.44)
10	1/4	FUR-GZ10-YZ4-	44.5(1.75)	17.2(0.68)	19.0(0.75)	18.0(0.71)	4.8(0.19)	15.2(0.60)	14.3(0.56)
10	5/16	FUR-GZ10-YZ5-	45.1(1.78)	17.2(0.68)	19.0(0.75)	18.0(0.71)	6.4(0.25)	16.2(0.64)	15.9(0.63)
10	3/8	FUR-GZ10-YZ6-	45.9(1.81)	17.2(0.68)	19.0(0.75)	18.0(0.71)	7.1(0.28)	16.8(0.66)	17.5(0.69)
12	5/16	FUR-GZ12-YZ5-	47.8(1.88)	22.8(0.90)	22.0(0.87)	22.0(0.87)	6.4(0.25)	16.2(0.64)	15.9(0.63)
12	3/8	FUR-GZ12-YZ6-	48.4(1.91)	22.8(0.90)	22.0(0.87)	22.0(0.87)	7.1(0.28)	16.8(0.66)	17.5(0.69)
15	1/2	FUR-GZ15-YZ8-	52.0(2.05)	24.4(0.96)	25.0(0.98)	24.0(0.94)	10.4(0.41)	22.9(0.90)	22.2(0.87)
16	5/8	FUR-GZ16-YZ10-	52.0(2.05)	24.4(0.96)	25.0(0.98)	24.0(0.94)	12.7(0.50)	24.4(0.96)	25.4(1.00)
20	1/2	FUR-GZ20-YZ8-	55.0(2.17)	26.0(1.02)	32.0(1.26)	30.0(1.18)	10.4(0.41)	22.9(0.90)	22.2(0.87)

## Муфта переходная

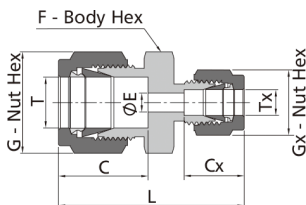

### Муфта переходная

Т-Трубка (дюймы.)	Тх- Трубка (дюймы.)	Артикул	Размеры, дюймы. (мм)							
			L	C	G	F	E	Cx	Gx	
1/8	1/16	FUR-YZ2-YZ1-	1.22(31.0)	0.50(12.7)	0.44(11.1)	0.44(11.1)	0.05(1.3)	0.34(8.6)	0.31(7.9)	
3/16	1/16	FUR-YZ3-YZ1-	1.27(32.3)	0.54(13.7)	0.50(12.7)	0.44(11.1)	0.05(1.3)	0.34(8.6)	0.31(7.9)	
3/16	1/8	FUR-YZ3-YZ2-	1.44(36.6)	0.54(13.7)	0.50(12.7)	0.44(11.1)	0.09(2.3)	0.50(12.7)	0.44(11.1)	
1/4	1/16	FUR-YZ4-YZ1-	1.35(34.3)	0.60(15.2)	0.56(14.3)	0.50(12.7)	0.05(1.3)	0.34(8.6)	0.31(7.9)	
1/4	1/8	FUR-YZ4-YZ2-	1.52(38.6)	0.60(15.2)	0.56(14.3)	0.50(12.7)	0.09(2.3)	0.50(12.7)	0.44(11.1)	
1/4	3/16	FUR-YZ4-YZ3-	1.55(39.4)	0.60(15.2)	0.56(14.3)	0.50(12.7)	0.12(3.0)	0.54(13.7)	0.50(12.7)	
5/16	1/8	FUR-YZ5-YZ2-	1.56(39.6)	0.64(16.2)	0.63(15.9)	0.56(14.3)	0.09(2.3)	0.50(12.7)	0.44(11.1)	
5/16	1/4	FUR-YZ5-YZ4-	1.66(42.2)	0.64(16.2)	0.63(15.9)	0.56(14.3)	0.19(4.8)	0.60(15.2)	0.56(14.3)	
3/8	1/16	FUR-YZ6-YZ1-	1.44(36.6)	0.66(16.8)	0.69(17.5)	0.63(15.9)	0.05(1.3)	0.34(8.6)	0.31(7.9)	
3/8	1/8	FUR-YZ6-YZ2-	1.61(40.9)	0.66(16.8)	0.69(17.5)	0.63(15.9)	0.09(2.3)	0.50(12.7)	0.44(11.1)	
3/8	1/4	FUR-YZ6-YZ4-	1.70(43.2)	0.66(16.8)	0.69(17.5)	0.63(15.9)	0.19(4.8)	0.60(15.2)	0.56(14.3)	
3/8	5/16	FUR-YZ6-YZ5-	1.74(44.2)	0.66(16.8)	0.69(17.5)	0.63(15.9)	0.25(6.4)	0.64(16.2)	0.63(15.9)	
1/2	1/8	FUR-YZ8-YZ2-	1.78(45.2)	0.90(22.8)	0.87(22.2)	0.81(20.6)	0.09(2.3)	0.50(12.7)	0.44(11.1)	
1/2	1/4	FUR-YZ8-YZ4-	1.85(47.0)	0.90(22.8)	0.87(22.2)	0.81(20.6)	0.19(4.8)	0.60(15.2)	0.56(14.3)	
1/2	3/8	FUR-YZ8-YZ6-	1.91(48.5)	0.90(22.8)	0.87(22.2)	0.81(20.6)	0.28(7.1)	0.66(16.8)	0.69(17.5)	
5/8	3/8	FUR-YZ10-YZ6-	1.94(49.3)	0.96(24.4)	1.00(25.4)	0.94(23.9)	0.28(7.1)	0.66(16.8)	0.69(17.5)	
5/8	1/2	FUR-YZ10-YZ8-	2.05(52.1)	0.96(24.4)	1.00(25.4)	0.94(23.9)	0.41(10.4)	0.90(22.8)	0.87(22.2)	
3/4	1/4	FUR-YZ12-YZ4-	1.94(49.3)	0.96(24.4)	1.13(28.6)	1.06(27.0)	0.19(4.8)	0.60(15.2)	0.56(14.3)	
3/4	3/8	FUR-YZ12-YZ6-	2.00(50.8)	0.96(24.4)	1.13(28.6)	1.06(27.0)	0.28(7.1)	0.66(16.8)	0.69(17.5)	
3/4	1/2	FUR-YZ12-YZ8-	2.11(53.6)	0.96(24.4)	1.13(28.6)	1.06(27.0)	0.41(10.4)	0.90(22.8)	0.87(22.2)	
3/4	5/8	FUR-YZ12-YZ10-	2.11(53.6)	0.96(24.4)	1.13(28.6)	1.06(27.0)	0.50(12.7)	0.96(24.4)	1.00(25.4)	
1	1/2	FUR-YZ16-YZ8-	2.38(60.5)	1.23(31.2)	1.50(38.1)	1.37(34.9)	0.41(10.4)	0.90(22.8)	0.87(22.2)	
1	3/4	FUR-YZ16-YZ12-	2.38(60.5)	1.23(31.2)	1.50(38.1)	1.37(34.9)	0.62(15.7)	0.96(24.4)	1.13(28.6)	

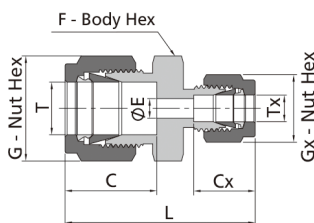

### Метрическая трубка

Т-Трубка (мм.)	Тх- Трубка (мм.)	Артикул	Размеры, дюймы. (мм)							
			L	C	G	F	E	Cx	Gx	
3	2	FUR-GZ3-GZ2-	35.3(1.39)	12.9(0.51)	12.0(0.47)	12.0(0.47)	1.7(0.07)	12.9(0.51)	12.0(0.47)	
6	2	FUR-GZ6-GZ2-	38.6(1.52)	15.3(0.60)	14.0(0.55)	14.0(0.55)	1.7(0.07)	12.9(0.51)	12.0(0.47)	
6	3	FUR-GZ6-GZ3-	38.6(1.52)	15.3(0.60)	14.0(0.55)	14.0(0.55)	2.4(0.09)	12.9(0.51)	12.0(0.47)	
6	4	FUR-GZ6-GZ4-	39.4(1.55)	15.3(0.60)	14.0(0.55)	14.0(0.55)	2.4(0.09)	13.7(0.54)	12.0(0.47)	
8	6	FUR-GZ8-GZ6-	42.3(1.67)	16.3(0.64)	16.0(0.63)	15.0(0.59)	4.8(0.19)	15.3(0.60)	14.0(0.55)	
10	6	FUR-GZ10-GZ6-	44.5(1.75)	17.2(0.68)	19.0(0.75)	18.0(0.71)	4.8(0.19)	15.3(0.60)	14.0(0.55)	
10	8	FUR-GZ10-GZ8-	45.1(1.78)	17.2(0.68)	19.0(0.75)	18.0(0.71)	6.4(0.25)	16.3(0.64)	16.0(0.63)	
12	6	FUR-GZ12-GZ6-	47.0(1.85)	22.8(0.90)	22.0(0.87)	22.0(0.87)	4.8(0.19)	15.3(0.60)	4.0(0.55)	
12	8	FUR-GZ12-GZ8-	47.8(1.88)	22.8(0.90)	22.0(0.87)	22.0(0.87)	6.4(0.25)	16.3(0.64)	16.0(0.63)	
12	10	FUR-GZ12-GZ10-	48.7(1.92)	22.8(0.90)	22.0(0.87)	22.0(0.87)	7.9(0.31)	17.2(0.68)	19.0(0.75)	
16	10	FUR-GZ16-GZ10-	49.5(1.95)	24.4(0.96)	25.0(0.98)	24.0(0.94)	7.9(0.31)	17.2(0.68)	19.0(0.75)	
16	12	FUR-GZ16-GZ12-	52.0(2.05)	24.4(0.96)	25.0(0.98)	24.0(0.94)	9.5(0.37)	22.8(0.90)	22.0(0.87)	
18	12	FUR-GZ18-GZ12-	53.5(2.11)	24.4(0.96)	30.0(1.18)	27.0(1.06)	9.5(0.37)	22.8(0.90)	22.0(0.87)	
25	18	FUR-GZ25-GZ18-	61.0(2.40)	31.3(1.23)	38.0(1.50)	35.0(1.38)	15.1(0.59)	24.4(0.96)	30.0(1.18)	
25	20	FUR-GZ25-GZ20-	62.3(2.45)	31.3(1.23)	38.0(1.50)	35.0(1.38)	15.9(0.63)	26.0(1.02)	32.0(1.26)	
30	18	FUR-GZ30-GZ18-	75.4(2.97)	39.6(1.56)	50.0(1.97)	46.0(1.81)	15.1(0.59)	24.4(0.96)	30.0(1.18)	
30	20	FUR-GZ30-GZ20-	75.4(2.97)	39.6(1.56)	50.0(1.97)	46.0(1.81)	15.9(0.63)	26.0(1.02)	32.0(1.26)	
30	25	FUR-GZ30-GZ25-	80.1(3.15)	39.6(1.56)	50.0(1.97)	46.0(1.81)	21.8(0.86)	31.3(1.23)	38.0(1.50)	
32	18	FUR-GZ32-GZ18-	77.8(3.06)	42.0(1.65)	50.0(1.97)	46.0(1.81)	15.1(0.59)	24.4(0.96)	30.0(1.18)	
32	20	FUR-GZ32-GZ20-	77.8(3.06)	42.0(1.65)	50.0(1.97)	46.0(1.81)	15.9(0.63)	26.0(1.02)	32.0(1.26)	
32	25	FUR-GZ32-GZ25-	82.3(3.24)	42.0(1.65)	50.0(1.97)	46.0(1.81)	21.8(0.86)	31.3(1.23)	38.0(1.50)	
38	20	FUR-GZ38-GZ20-	87.5(3.44)	49.4(1.94)	60.0(2.36)	55.0(2.17)	15.9(0.63)	26.0(1.02)	32.0(1.26)	
38	25	FUR-GZ38-GZ25-	92.0(3.62)	49.4(1.94)	60.0(2.36)	55.0(2.17)	21.8(0.86)	31.3(1.23)	38.0(1.50)	
38	30	FUR-GZ38-GZ30-	104.6(4.12)	49.4(1.94)	60.0(2.36)	55.0(2.17)	26.2(1.03)	39.6(1.56)	50.0(1.97)	

## Муфта проходная с монтажной гайкой

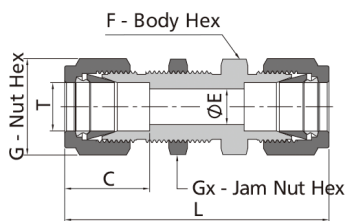

### Дюймовая трубка

Т-Трубка (дюймы.)	Артикул	Размеры, дюймы. (мм)						Размер отверстия в панели дюймы. (мм)	Макс толщина панели дюймы. (мм)
		L	C	E	G	F	Gx		
1/16	FUPN-YZ1-	1.24(31.5)	0.34(8.6)	0.05(1.3)	0.31(7.9)	0.31(7.9)	0.31(7.9)	0.20(5.2)	0.12(3.0)
1/8	FUPN-YZ2-	2.02(51.3)	0.50(12.7)	0.09(2.3)	0.44(11.1)	0.50(12.7)	0.50(12.7)	0.33(8.3)	0.50(12.7)
3/16	FUPN-YZ3-	2.11(53.6)	0.54(13.7)	0.12(3.0)	0.50(12.7)	0.56(14.3)	0.56(14.3)	0.39(9.9)	0.50(12.7)
1/4	FUPN-YZ4-	2.27(57.7)	0.60(15.2)	0.19(4.8)	0.56(14.3)	0.63(15.9)	0.63(15.9)	0.45(11.5)	0.40(10.2)
5/16	FUPN-YZ5-	2.39(60.7)	0.64(16.3)	0.25(6.4)	0.63(15.9)	0.69(17.5)	0.69(17.5)	0.52(13.1)	0.44(11.2)
3/8	FUPN-YZ6-	2.45(62.2)	0.66(16.8)	0.28(7.1)	0.69(17.5)	0.75(19.1)	0.75(19.1)	0.58(14.7)	0.44(11.2)
1/2	FUPN-YZ8-	2.80(71.1)	0.90(22.9)	0.41(10.4)	0.87(22.2)	0.94(23.8)	0.94(23.8)	0.76(19.4)	0.50(12.7)
5/8	FUPN-YZ10-	2.86(72.6)	0.96(24.4)	0.50(12.7)	1.00(25.4)	1.06(27.0)	1.06(27.0)	0.89(22.6)	0.50(12.7)
3/4	FUPN-YZ12-	3.11(79.0)	0.96(24.4)	0.62(15.7)	1.13(28.6)	1.19(30.2)	1.19(30.2)	1.02(25.8)	0.66(16.8)
7/8	FUPN-YZ14-	3.35(85.2)	1.02(25.9)	0.72(18.3)	1.25(31.8)	1.38(34.9)	1.37(34.9)	1.14(29.0)	0.75(19.1)
1	FUPN-YZ16-	3.77(95.8)	1.23(31.2)	0.88(22.4)	1.50(38.1)	1.63(41.3)	1.63(41.3)	1.33(33.7)	0.75(19.1)
1 1/4	FUPN-YZ20-	4.85(123.2)	1.62(41.1)	1.09(27.8)	1.87(47.6)	1.87(47.6)	1.87(47.6)	1.64(41.7)	0.75(19.1)
1 1/2	FUPN-YZ24-	5.48(139.2)	1.97(50.0)	1.34(34.0)	2.25(57.2)	2.25(57.2)	2.25(57.2)	1.95(49.6)	0.75(19.1)

### Метрическая трубка

Т-Трубка (мм.)	Артикул	Размеры, дюймы. (мм)						Размер отверстия в панели дюймы. (мм)	Макс толщина панели дюймы. (мм)
		L	C	E	G	F	Gx		
3	FUPN-GZ3-	51.3(2.02)	12.9(0.51)	2.4(0.09)	12.0(0.47)	14.0(0.55)	14.0(0.55)	8.3(0.33)	12.7(0.50)
4	FUPN-GZ4-	53.6(2.11)	13.7(0.54)	2.4(0.09)	12.0(0.47)	14.0(0.55)	14.0(0.55)	9.9(0.39)	12.7(0.50)
6	FUPN-GZ6-	57.7(2.27)	15.3(0.60)	4.8(0.19)	14.0(0.55)	16.0(0.63)	16.0(0.63)	11.5(0.45)	10.2(0.40)
8	FUPN-GZ8-	61.0(2.40)	16.2(0.64)	6.4(0.25)	16.0(0.63)	18.0(0.71)	18.0(0.71)	13.1(0.52)	11.2(0.44)
10	FUPN-GZ10--	63.7(2.51)	17.2(0.68)	7.9(0.31)	19.0(0.75)	22.0(0.87)	22.0(0.87)	16.3(0.64)	11.2(0.44)
12	FUPN-GZ12-	71.0(2.80)	22.8(0.90)	9.5(0.37)	22.0(0.87)	24.0(0.94)	24.0(0.94)	19.5(0.77)	12.7(0.50)
14	FUPN-GZ14-	72.5(2.85)	24.4(0.96)	11.1(0.44)	25.0(0.98)	27.0(1.06)	27.0(1.06)	22.5(0.89)	12.7(0.50)
15	FUPN-GZ15-	72.5(2.85)	24.4(0.96)	11.9(0.47)	25.0(0.98)	27.0(1.06)	27.0(1.06)	22.8(0.90)	12.7(0.50)
16	FUPN-GZ16-	72.5(2.85)	24.4(0.96)	12.7(0.50)	25.0(0.98)	27.0(1.06)	27.0(1.06)	22.8(0.90)	12.7(0.50)
18	FUPN-GZ18-	78.9(3.11)	24.4(0.96)	15.1(0.59)	30.0(1.18)	30.0(1.18)	30.0(1.18)	26.0(1.02)	16.8(0.66)
20	FUPN-GZ20-	84.5(3.33)	26.0(1.02)	15.9(0.63)	32.0(1.26)	35.0(1.38)	35.0(1.38)	29.0(1.14)	19.0(0.75)
25	FUPN-GZ25-	96.0(3.78)	31.3(1.23)	21.8(0.86)	38.0(1.5)	41.0(1.61)	41.0(1.61)	34.0(1.34)	19.0(0.75)
30	FUPN-GZ30-	124.0(4.88)	39.6(1.56)	26.2(1.03)	50.0(1.97)	50.0(1.97)	50.0(1.97)	40.5(1.59)	19.0(0.75)
32	FUPN-GZ32-	128.0(5.04)	42.0(1.65)	28.6(1.13)	50.0(1.97)	50.0(1.97)	50.0(1.97)	42.5(1.67)	19.0(0.75)
38	FUPN-GZ38-	145.0(5.71)	49.4(1.94)	33.7(1.33)	60.0(2.36)	60.0(2.36)	60.0(2.36)	50.5(1.99)	19.0(0.75)

# Размеры

## Муфта переходная с монтажной гайкой

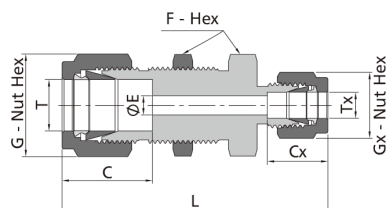

### Дюймовая трубка

Т-Трубка (дюймы.)	Тх-Трубка (дюймы.)	Артикул	Размеры, дюймы. (мм)							Размер отверстия в панели дюймы. (мм)	Макс толщина панели дюймы. (мм)
			L	C	G	F	E	Cx	Gx		
1/4	1/8	FURN-YZ4-YZ2-	2.17(55.1)	0.60(15.2)	0.09(2.3)	0.56(14.3)	0.63(15.9)	0.50(12.7)	0.44(11.1)	0.45(11.5)	0.40(10.2)
3/8	1/4	FURN-YZ6-YZ4-	2.39(60.7)	0.66(16.8)	0.19(4.8)	0.69(17.5)	0.75(19.1)	0.60(15.2)	0.56(14.3)	0.58(14.7)	0.44(11.2)
1/2	1/4	FURN-YZ8-YZ4-	2.63(66.8)	0.90(22.9)	0.19(4.8)	0.87(22.2)	0.94(23.8)	0.60(15.2)	0.56(14.3)	0.76(19.4)	0.50(12.7)

### Метрическая трубка

Т-Трубка (мм.)	Тх-Трубка (мм.)	Артикул	Размеры, дюймы. (мм)							Размер отверстия в панели дюймы. (мм)	Макс толщина панели дюймы. (мм)
			L	C	G	F	E	Cx	Gx		
6	3	FURN-GZ6-GZ3-	55.1(2.17)	15.3(0.60)	2.4(0.09)	14.0(0.55)	16.0(0.63)	12.9(0.51)	12.0(0.47)	11.5(0.45)	10.2(0.40)
8	6	FURN-GZ8-GZ6-	60.1(2.37)	16.2(0.64)	4.8(0.19)	16.0(0.63)	18.0(0.71)	15.3(0.60)	14.0(0.55)	13.1(0.52)	11.2(0.44)
12	8	FURN-GZ12-GZ8-	67.6(2.66)	22.8(0.90)	6.4(0.25)	22.0(0.87)	24.0(0.94)	16.2(0.64)	16.0(0.63)	19.5(0.77)	12.7(0.50)

## Муфта переходная с монтажной гайкой

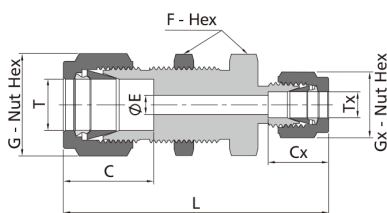

### Дюймовая трубка

Т-Трубка (дюймы.)	Тх-Трубка (мм.)	Артикул	Размеры, дюймы. (мм)							Размер отверстия в панели дюймы. (мм)	Макс толщина панели дюймы. (мм)
			L	C	G	F	E	Cx	Gx		
1/4	6	FURN-YZ4-GZ6-	2.27(57.7)	0.60(15.2)	0.19(4.8)	0.56(14.3)	0.63(15.9)	0.60(15.3)	0.55(14.0)	0.45(11.5)	0.40(10.2)

### Метрическая часть

### Метрическая трубка

Т-Трубка (мм.)	Тх-Трубка (дюймы.)	Артикул	Размеры, дюймы. (мм)							Размер отверстия в панели дюймы. (мм)	Макс толщина панели дюймы. (мм)
			L	C	G	F	E	Cx	Gx		
6	1/8	FURN-GZ6-YZ2-	55.1(2.17)	15.3(0.60)	2.3(0.09)	14.0(0.55)	16.0(0.63)	12.7(0.5)	11.0(0.43)	11.5(0.45)	10.2(0.40)
6	1/4	FURN-GZ6-YZ4	57.7(2.27)	15.3(0.60)	4.8(0.19)	14.0(0.55)	16.0(0.63)	15.2(0.6)	14.3(0.56)	11.5(0.45)	10.2(0.40)

### Дюймовая трубка

## Муфта проходная под приварку

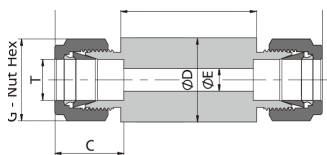

### Дюймовая трубка

Тх-Трубка (дюймы)	Артикул	Размеры, дюймы. (мм)					
		L	C	E	G	D	I
1/8	FUPG-YZ2-	3.16(80.2)	0.50(12.7)	0.09(2.3)	0.44(11.1)	0.47(12.0)	1.97(50.0)
3/16	FUPG-YZ3-	3.24(82.2)	0.54(13.7)	0.12(3.0)	0.50(12.7)	0.47(12.0)	1.97(50.0)
1/4	FUPG-YZ4-	3.35(85.2)	0.60(15.2)	0.19(4.8)	0.56(14.3)	0.55(14.0)	1.97(50.0)
5/16	FUPG-YZ5-	3.43(87.2)	0.64(16.2)	0.25(6.4)	0.63(15.9)	0.63(16.0)	1.97(50.0)
3/8	FUPG-YZ6-	3.49(88.6)	0.66(16.8)	0.28(7.1)	0.69(17.5)	0.75(19.0)	1.97(50.0)
1/2	FUPG-YZ8-	3.69(93.8)	0.90(22.9)	0.41(10.4)	0.87(22.2)	0.91(23.0)	1.97(50.0)
5/8	FUPG-YZ10-	3.69(93.6)	0.96(24.4)	0.50(12.7)	1.00(25.4)	1.10(28.0)	1.97(50.0)
3/4	FUPG-YZ12-	3.72(94.4)	0.96(24.4)	0.62(15.7)	1.13(28.6)	1.26(32.0)	1.97(50.0)
7/8	FUPG-YZ14-	3.72(94.4)	1.02(25.9)	0.72(18.3)	1.25(31.8)	1.26(32.0)	1.97(50.0)
1	FUPG-YZ16-	4.06(103.2)	1.23(31.2)	0.88(22.4)	1.50(38.1)	1.38(35.0)	1.97(50.0)
1-1/4	FUPG-YZ20-	5.05(128.2)	1.62(41.1)	1.09(27.7)	1.87(47.6)	1.97(50.0)	1.97(50.0)
1-1/2	FUPG-YZ24-	5.54(140.8)	1.97(50.0)	1.34(34.0)	2.25(57.2)	2.17(55.0)	1.97(50.0)
2	FUPG-YZ32-	6.93(176.0)	2.67(67.8)	1.81(46.0)	3.00(76.2)	3.15(80.0)	1.97(50.0)

### Метрическая трубка

Тх-Трубка (мм.)	Артикул	Размеры, дюймы. (мм)					
		L	C	E	G	D	I
3	FUPG-GZ3-	80.8(3.18)	12.9(0.51)	2.4(0.09)	12.0(0.47)	12.0(0.47)	50.0(1.97)
4	FUPG-GZ4-	82.4(3.24)	13.7(0.54)	2.4(0.09)	12.0(0.47)	12.0(0.47)	50.0(1.97)
6	FUPG-GZ6-	86.0(3.39)	15.3(0.60)	4.8(0.19)	14.0(0.55)	12.0(0.47)	50.0(1.97)
8	FUPG-GZ8-	87.4(3.44)	16.2(0.64)	6.4(0.25)	16.0(0.63)	16.0(0.63)	50.0(1.97)
10	FUPG-GZ10-	89.0(3.50)	17.2(0.68)	7.9(0.31)	19.0(0.75)	19.0(0.75)	50.0(1.97)
12	FUPG-GZ12-	94.2(3.71)	22.8(0.90)	9.5(0.37)	22.0(0.87)	23.0(0.91)	50.0(1.97)
15	FUPG-GZ15-	93.8(3.69)	24.4(0.96)	11.9(0.47)	25.0(0.98)	25.0(0.98)	50.0(1.97)
16	FUPG-GZ16-	94.4(3.72)	24.4(0.96)	12.7(0.50)	25.0(0.98)	28.0(1.10)	50.0(1.97)
18	FUPG-GZ18-	94.0(3.70)	24.4(0.96)	15.1(0.59)	30.0(1.18)	28.0(1.10)	50.0(1.97)
20	FUPG-GZ20-	94.0(3.70)	26.0(1.02)	15.9(0.63)	32.0(1.26)	32.0(1.26)	50.0(1.97)
22	FUPG-GZ22-	94.0(3.70)	26.0(1.02)	18.3(0.72)	32.0(1.26)	32.0(1.26)	50.0(1.97)
25	FUPG-GZ25-	103.2(4.06)	31.3(1.23)	21.8(0.86)	38.0(1.50)	38.0(1.50)	50.0(1.97)
28	FUPG-GZ28-	123.2(4.85)	36.6(1.44)	21.8(0.86)	46.0(1.81)	45.0(1.77)	50.0(1.97)
32	FUPG-GZ32-	133.2(5.24)	42.0(1.65)	28.6(1.13)	50.0(1.97)	50.0(1.97)	50.0(1.97)
38	FUPG-GZ38-	146.2(5.76)	49.4(1.94)	33.7(1.33)	60.0(2.36)	60.0(2.36)	50.0(1.97)

## Монтажная гайка

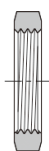

### Дюймовая трубка

Тх-Трубка (дюймы)	Артикул
1/16	FN-YZ1-
1/8	FN-YZ2-
3/16	FN-YZ3-
1/4	FN-YZ4-
5/16	FN-YZ5-
3/8	FN-YZ6-
1/2	FN-YZ8-
5/8	FN-YZ10-
3/4	FN-YZ12-
7/8	FN-YZ14-
1	FN-YZ16-
1 1/4	FN-YZ20-
1 1/2	FN-YZ24-

### Метрическая трубка

Тх-Трубка (мм)	Артикул
3	FN-GZ3-
4	FN-GZ4-
6	FN-GZ6-
8	FN-GZ8-
10	FN-GZ10-
12	FN-GZ12-
14	FN-GZ14-
18	FN-GZ18-
20	FN-GZ20-
22	FN-GZ22-
25	FN-GZ25-
28	FN-GZ28-
30	FN-GZ30-
32	FN-GZ32-
38	FN-GZ38-

# Размеры

## Угольник с наружной резьбой

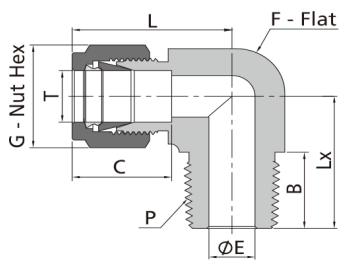

Размер E наименьший номинальный размер.

### Дюймовая трубка

### Резьба NPT

Т-Трубка. (дюймы.)	P-NPT Резьба	Артикул	Размеры, дюймы. (мм)						
			L	C	G	F	E	B	Lx
1/16	1/16	FYM-YZ1-NPT1-	0.75(19.1)	0.34(8.6)	0.31(7.9)	0.44(11.1)	0.05(1.3)	0.38(9.7)	0.70(17.8)
1/16	1/8	FYM-YZ1-NPT2-	0.75(19.1)	0.34(8.6)	0.31(7.9)	0.44(11.1)	0.05(1.3)	0.38(9.7)	0.70(17.8)
1/8	1/16	FYM-YZ2-NPT1-	0.93(23.6)	0.50(12.7)	0.44(11.1)	0.44(11.1)	0.09(2.4)	0.38(9.7)	0.70(17.8)
1/8	1/8	FYM-YZ2-NPT2-	0.93(23.6)	0.50(12.7)	0.44(11.1)	0.44(11.1)	0.09(2.4)	0.38(9.7)	0.70(17.8)
1/8	1/4	FYM-YZ2-NPT4-	0.97(24.6)	0.50(12.7)	0.44(11.1)	0.50(12.7)	0.09(2.4)	0.56(14.2)	0.92(23.4)
3/16	1/8	FYM-YZ3-NPT2-	1.00(25.4)	0.54(13.7)	0.50(12.7)	0.50(12.7)	0.12(3.0)	0.38(9.7)	0.74(18.8)
3/16	1/4	FYM-YZ3-NPT4-	1.00(25.4)	0.54(13.7)	0.50(12.7)	0.50(12.7)	0.12(3.0)	0.56(14.2)	0.92(23.4)
1/4	1/16	FYM-YZ4-NPT1-	1.06(26.9)	0.60(15.2)	0.56(14.3)	0.50(12.7)	0.12(3.0)	0.38(9.7)	0.74(18.8)
1/4	1/8	FYM-YZ4-NPT2-	1.06(26.9)	0.60(15.2)	0.56(14.3)	0.50(12.7)	0.19(4.8)	0.38(9.7)	0.74(18.8)
1/4	1/4	FYM-YZ4-NPT4-	1.06(26.9)	0.60(15.2)	0.56(14.3)	0.50(12.7)	0.19(4.8)	0.56(14.2)	0.92(23.4)
1/4	3/8	FYM-YZ4-NPT6-	1.17(29.7)	0.60(15.2)	0.56(14.3)	0.69(17.5)	0.19(4.8)	0.56(14.2)	1.03(26.2)
1/4	1/2	FYM-YZ4-NPT8-	1.25(31.8)	0.60(15.2)	0.56(14.3)	0.81(20.6)	0.19(4.8)	0.75(19.1)	1.30(33.0)
5/16	1/8	FYM-YZ5-NPT2-	1.13(28.7)	0.64(16.3)	0.63(15.9)	0.56(14.3)	0.19(4.8)	0.38(9.7)	0.78(19.8)
5/16	1/4	FYM-YZ5-NPT4-	1.13(28.7)	0.64(16.3)	0.63(15.9)	0.56(14.3)	0.25(6.4)	0.56(14.2)	0.96(24.4)
5/16	3/8	FYM-YZ5-NPT6-	1.20(30.5)	0.64(16.3)	0.63(15.9)	0.69(17.5)	0.25(6.4)	0.56(14.2)	1.03(26.2)
3/8	1/8	FYM-YZ6-NPT2-	1.20(30.5)	0.66(16.8)	0.69(17.5)	0.63(15.9)	0.19(4.8)	0.38(9.7)	0.82(20.8)
3/8	1/4	FYM-YZ6-NPT4-	1.20(30.5)	0.66(16.8)	0.69(17.5)	0.63(15.9)	0.28(7.1)	0.56(14.2)	1.00(25.4)
3/8	3/8	FYM-YZ6-NPT6-	1.23(31.2)	0.66(16.8)	0.69(17.5)	0.69(17.5)	0.28(7.1)	0.56(14.2)	1.03(26.2)
3/8	1/2	FYM-YZ6-NPT8-	1.31(33.3)	0.66(16.8)	0.69(17.5)	0.81(20.6)	0.28(7.1)	0.75(19.1)	1.30(33.0)
3/8	3/4	FYM-YZ6-NPT12-	1.46(37.1)	0.66(16.8)	0.69(17.5)	1.06(27.0)	0.28(7.1)	0.75(19.1)	1.45(36.8)
1/2	1/4	FYM-YZ8-NPT4-	1.42(36.1)	0.90(22.9)	0.87(22.2)	0.81(20.6)	0.28(7.1)	0.56(14.2)	1.11(28.2)
1/2	3/8	FYM-YZ8-NPT6-	1.42(36.1)	0.90(22.9)	0.87(22.2)	0.81(20.6)	0.38(9.7)	0.56(14.2)	1.11(28.2)
1/2	1/2	FYM-YZ8-NPT8-	1.42(36.1)	0.90(22.9)	0.87(22.2)	0.81(20.6)	0.41(10.4)	0.75(19.1)	1.30(33.0)
1/2	3/4	FYM-YZ8-NPT12-	1.57(39.9)	0.90(22.9)	0.87(22.2)	1.06(27.0)	0.41(10.4)	0.75(19.1)	1.45(36.8)
5/8	3/8	FYM-YZ10-NPT6-	1.50(38.1)	0.96(24.4)	1.00(25.4)	0.94(23.8)	0.38(9.7)	0.56(14.2)	1.19(30.2)
5/8	1/2	FYM-YZ10-NPT8-	1.50(38.1)	0.96(24.4)	1.00(25.4)	0.94(23.8)	0.47(11.9)	0.75(19.1)	1.38(35.1)
5/8	3/4	FYM-YZ10-NPT12-	1.57(39.9)	0.96(24.4)	1.00(25.4)	1.06(27.0)	0.50(12.7)	0.75(19.1)	1.45(36.8)
3/4	1/2	FYM-YZ12-NPT8-	1.57(39.9)	0.96(24.4)	1.13(28.6)	1.06(27.0)	0.47(11.9)	0.75(19.1)	1.45(36.8)
3/4	3/4	FYM-YZ12-NPT12-	1.57(39.9)	0.96(24.4)	1.13(28.6)	1.06(27.0)	0.62(15.7)	0.75(19.1)	1.45(36.8)
7/8	3/4	FYM-YZ14-NPT12-	1.76(44.7)	1.02(25.9)	1.25(31.8)	1.37(34.9)	0.62(15.7)	0.75(19.1)	1.64(41.7)
1	3/4	FYM-YZ16-NPT12-	1.93(49.0)	1.23(31.2)	1.50(38.1)	1.37(34.9)	0.62(15.7)	0.75(19.1)	1.64(41.7)
1	1	FYM-YZ16-NPT16-	1.93(49.0)	1.23(31.2)	1.50(38.1)	1.37(34.9)	0.88(22.4)	0.94(23.9)	1.83(46.5)
1 1/4	1 1/4	FYM-YZ20-NPT20-	2.62(66.5)	1.62(41.1)	1.87(47.6)	1.69(42.9)	1.09(27.7)	0.94(23.9)	2.06(52.4)
1 1/2	1 1/2	FYM-YZ24-NPT24-	3.07(78.0)	1.97(50.0)	2.25(57.2)	2.00(50.8)	1.34(34.0)	1.03(26.2)	2.38(60.5)

### Fractional Tube

### Коническая резьба ISO (RT)

Т-Трубка. (дюймы.)	P-RT Резьба	Артикул	Размеры, дюймы. (мм)						
			L	C	G	F	E	B	Lx
1/8	1/8	FYM-YZ2-RT2-	0.93(23.6)	0.50(12.7)	0.44(11.1)	0.44(11.1)	0.09(2.4)	0.38(9.7)	0.87(22.2)
1/8	1/4	FYM-YZ2-RT4-	0.97(24.6)	0.50(12.7)	0.44(11.1)	0.50(12.7)	0.09(2.4)	0.56(14.2)	0.92(23.4)
1/4	1/8	FYM-YZ4-RT2-	1.06(26.9)	0.60(15.2)	0.56(14.3)	0.50(12.7)	0.19(4.8)	0.38(9.7)	0.74(18.8)
1/4	1/4	FYM-YZ4-RT4-	1.06(26.9)	0.60(15.2)	0.56(14.3)	0.50(12.7)	0.19(4.8)	0.56(14.2)	0.92(23.4)
1/4	3/8	FYM-YZ4-RT6-	1.17(29.7)	0.60(15.2)	0.56(14.3)	0.69(17.5)	0.19(4.8)	0.56(14.2)	1.03(26.2)
1/4	1/2	FYM-YZ4-RT8-	1.25(31.8)	0.60(15.2)	0.56(14.3)	0.81(20.6)	0.19(4.8)	0.75(19.1)	1.30(33.0)
5/16	1/4	FYM-YZ5-RT4-	1.13(28.7)	0.64(16.3)	0.63(15.9)	0.56(14.3)	0.25(6.4)	0.56(14.2)	0.96(24.4)
3/8	1/8	FYM-YZ6-RT2-	1.20(30.5)	0.66(16.8)	0.69(17.5)	0.63(15.9)	0.19(4.8)	0.38(9.7)	0.82(20.8)
3/8	1/4	FYM-YZ6-RT4-	1.20(30.5)	0.66(16.8)	0.69(17.5)	0.63(15.9)	0.28(7.1)	0.56(14.2)	1.00(25.4)
3/8	3/8	FYM-YZ6-RT6-	1.23(31.2)	0.66(16.8)	0.69(17.5)	0.69(17.5)	0.28(7.1)	0.56(14.2)	1.03(26.2)
1/2	3/8	FYM-YZ8-RT6-	1.42(36.1)	0.90(22.9)	0.87(22.2)	0.81(20.6)	0.38(9.7)	0.56(14.2)	1.11(28.2)
1/2	1/2	FYM-YZ8-RT8-	1.42(36.1)	0.90(22.9)	0.87(22.2)	0.81(20.6)	0.41(10.4)	0.75(19.1)	1.30(33.0)
3/4	1/2	FYM-YZ12-RT8-	1.57(39.9)	0.96(24.4)	1.13(28.6)	1.06(27.0)	0.37(9.5)	0.75(19.1)	1.45(36.8)
1	1	FYM-YZ16-RT16-	1.93(49.0)	1.23(31.2)	1.50(38.1)	1.37(34.9)	0.88(22.4)	0.94(23.9)	1.83(46.5)



## Угольник с наружной резьбой

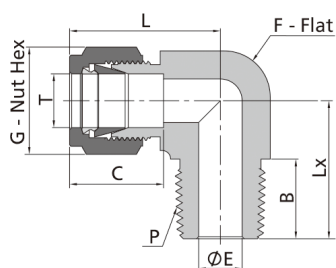

Размер E наименьший номинальный размер.

Метрическая трубка			Резьба NPT						
Т-Трубка. (мм.)	P-NPT Резьба	Артикул	Размеры, дюймы. (мм)						
			L	C	G	F	E	B	Lx
3	1/8	FYM-GZ3-NPT2-	23.6(0.93)	12.9(0.51)	12.0(0.47)	11.1(0.44)	2.4(0.09)	9.7(0.38)	17.8(0.70)
3	1/4	FYM-GZ3-NPT4-	24.6(0.97)	12.9(0.51)	12.0(0.47)	12.7(0.50)	2.4(0.09)	14.2(0.56)	23.4(0.92)
4	1/8	FYM-GZ4-NPT2-	25.4(1.00)	13.7(0.54)	12.0(0.47)	12.7(0.50)	2.4(0.09)	9.7(0.38)	18.8(0.74)
4	1/4	FYM-GZ4-NPT4-	25.4(1.00)	13.7(0.54)	12.0(0.47)	12.7(0.50)	2.4(0.09)	14.2(0.56)	23.4(0.92)
6	1/8	FYM-GZ6-NPT2-	27.0(1.06)	15.3(0.60)	14.0(0.55)	12.7(0.50)	a.s0.19	9.7(0.38)	18.8(0.74)
6	1/4	FYM-GZ6-NPT4-	27.0(1.06)	15.3(0.60)	14.0(0.55)	12.7(0.50)	4.8(0.19)	14.2(0.56)	23.4(0.92)
6	3/8	FYM-GZ6-NPT6-	29.8(1.17)	15.3(0.60)	14.0(0.55)	17.5(0.69)	4.8(0.19)	14.2(0.56)	26.2(1.03)
6	1/2	FYM-GZ6-NPT8-	31.8(1.25)	15.3(0.60)	14.0(0.55)	20.6(0.81)	4.8(0.19)	19.1(0.75)	330(130)
8	1/8	FYM-GZ8-NPT2-	28.8(1.13)	16.2(0.64)	16.0(0.63)	14.3(0.56)	4.80.19)	9.7(0.38)	19.8(0.78)
8	1/4	FYM-GZ8-NPT4-	28.8(1.13)	16.2(0.64)	16.0(0.63)	14.3(0.56)	6.4(0.25)	14.2(0.56)	24.4(0.96)
8	3/8	FYM-GZ8-NPT6-	30.6(1.20)	16.2(0.64)	16.0(0.63)	17.5(0.69)	6.4(0.25)	14.2(0.56)	26.2(1.03)
8	1/2	FYM-GZ8-NPT8-	32.6(1.28)	16.2(0.64)	16.0(0.63)	20.6(0.81)	6.4(0.25)	19.1(0.75)	33.0(1.30)
10	1/8	FYM-GZ10-NPT2-	31.5(1.24)	17.2(0.68)	19.0(0.75)	17.5(0.69)	4.8(0.19)	9.7(0.38)	21.6(0.85)
10	1/4	FYM-GZ10-NPT4-	31.5(1.24)	17.2(0.68)	19.0(0.75)	17.5(0.69)	7.1(0.28)	14.2(0.56)	26.2(1.03)
10	3/8	FYM-GZ10-NPT6-	31.5(1.24)	17.2(0.68)	19.0(0.75)	17.5(0.69)	7.90031)	14.2(0.56)	26.2(1.03)
10	1/2	FYM-GZ10-NPT8-	33.5(1.32)	17.2(0.68)	19.0(0.75)	20.6(0.81)	7.9(0.31)	19.1(0.75)	33.0(1.30)
12	1/8	FYM-GZ12-NPT2-	36.0(1.42)	22.8(0.90)	22.0(0.87)	20.6(0.81)	4.8(0.19)	9.7(0.38)	23.6(0.93)
12	1/4	FYM-GZ12-NPT4-	36.0(1.42)	22.8(0.90)	22.0(0.87)	20.6(0.81)	7.1(0.28)	14.2(0.56)	28.2(1.11)
12	3/8	FYM-GZ12-NPT6-	36.1.42	22.8(0.90)	22.0087)	20.6(0.81)	9.5(0.37)	14.200.56	28.2(1.11)
12	1/2	FYM-GZ12-NPT8-	36.0(1.42)	22.8(0.90)	22.0087)	20.6(0.81)	9.5(0.37)	19.1(0.75)	33.0(1.30)
12	3/4	FYM-GZ12-NPT12-	39.8(1.57)	22.8(0.90)	22.0(0.87)	27.0(1.06)	9.5(0.37)	19.1(0.75)	36.8(1.45)
15	1/2	FYM-GZ15-NPT8-	38.0(1.50)	24.4(0.96)	25.0(0.98)	23.8(0.94)	11.9(0.47)	19.1(0.75)	35.1(1.38)
16	1/4	FYM-GZ16-NPT4-	38.0(1.50)	24.4(0.96)	25.0098)	23.8(0.94)	7.11028	14.2(0.56)	30.2(1.19)
10	3/8	FYM-GZ10-NPT6-	38.1.50	24.400.90	25.0(0.98)	23.8(0.94)	9.500.37	14.2(0.56)	30.2(1.19)
16	1/2	FYM-GZ16-NPT8-	38.0(1.50)	24.4(0.96)	25.0(0.98)	23.8(0.94)	11.9(0.47)	19.1(0.75)	35.1(1.38)
16	3/4	FYM-GZ16-NPT12-	39.8(1.57)	24.4(0.96)	25.0(0.98)	27.0(1.06)	12.7(0.50)	19.1(0.75)	36.8(1.45)
18	1/2	FYM-GZ18-NPT8-	39.8(1.57)	24.4(0.96)	30.0(1.18)	27.0(1.06)	11.9(0.47)	19.1(0.75)	36.8(1.45)
18	3/4	FYM-GZ18-NPT12-	39.8(1.57)	24.4(0.96)	30.0(1.18)	27.0(1.06)	15.1(0.59)	19.1(0.75)	36.8(1.45)
20	1/2	FYM-GZ20-NPT8-	44.6(1.76)	26.0(1.02)	32.0(1.26)	34.9(1.37)	11.900.47)	19.1(0.75)	41.7(1.64)
20	3/4	FYM-GZ20-NPT12-	44.6(1.76)	26.0(1.02)	32.0(1.26)	34.9(1.37)	15.9(0.63)	19.1(0.75)	41.7(1.64)
22	3/4	FYM-GZ22-NPT12-	44.6(1.76)	26.0(1.02)	32.0(1.26)	34.9(1.37)	15.9(0.63)	19.1(0.75)	41.7(1.64)
22	1	FYM-GZ22-NPT16-	44.6(1.76)	26.0(1.02)	32.0(1.26)	34.9(1.37)	18.3(0.72)	23.9(0.94)	46.5(1.83)
25	3/4	FYM-GZ25-NPT12-	49.1(1.93)	31.3(1.23)	38.0(1.50)	34.9(1.37)	15.9(0.63)	19.1(0.75)	41.7(1.64)
25	1	FYM-GZ25-NPT16-	49.1(1.93)	31.3(1.23)	38.0(1.50)	34.9(1.37)	21.8(0.86)	23.9(0.94)	46.5(1.83)
30	1 1/4	FYM-GZ30-NPT20-	69.9(2.75)	39.6(1.56)	50.0(1.97)	42.9(1.69)	26.2(1.03)	23.9(0.94)	53.1(2.09)
32	1 1/4	FYM-GZ32-NPT20-	72.3(2.85)	42.0(1.65)	50.0(1.97)	42.9(1.69)	27.8(1.09)	23.9(0.94)	53.1(2.09)
38	1 1/2	FYM-GZ38-NPT24-	84.0(3.31)	49.4(1.94)	60.0(2.36)	50.8(2.00)	33.7(1.33)	26.2(1.03)	60.4(2.38)

# Размеры

## Угольник с наружной резьбой

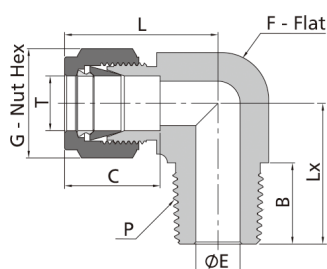

Размер E наименьший номинальный размер.

Metric Tube			Коническая резьба ISO (RT)						
Т-Трубка. (мм.)	P-RT Резьба	Артикул	Размеры, дюймы. (мм)						
			L	C	G	F	E	B	Lx
3	1/8	FYM-GZ3-RT2-	23.6(0.93)	12.9(0.51)	12.0(0.47)	11.1(0.44)	2.4(0.09)	9.7(0.38)	17.8(0.70)
3	1/4	FYM-GZ3-RT4-	24.6(0.97)	12.9(0.51)	12.0(0.47)	12.7(0.50)	2.4(0.09)	14.2(0.56)	23.4(0.92)
4	1/8	FYM-GZ4-RT2-	25.4(1.00)	13.7(0.54)	12.0(0.47)	12.7(0.50)	2.4(0.09)	9.7(0.38)	18.8(0.74)
4	1/4	FYM-GZ4-RT4-	25.4(1.00)	13.7(0.54)	12.0(0.47)	12.7(0.50)	2.4(0.09)	14.2(0.56)	23.4(0.92)
6	1/8	FYM-GZ6-RT2-	27.0(1.06)	15.3(0.60)	14.0(0.55)	12.7(0.50)	4.8(0.19)	9.7(0.38)	18.8(0.74)
6	1/4	FYM-GZ6-RT4-	27.0(1.06)	15.3(0.60)	14.0(0.55)	12.7(0.50)	4.8(0.19)	14.2(0.56)	23.4(0.92)
6	3/8	FYM-GZ6-RT6-	29.8(1.17)	15.3(0.60)	14.0(0.55)	17.5(0.69)	4.8(0.19)	14.2(0.56)	26.2(1.03)
6	1/2	FYM-GZ6-RT8-	31.8(1.25)	15.3(0.60)	14.0(0.55)	20.6(0.81)	4.8(0.19)	19.1(0.75)	33.0(1.30)
8	1/8	FYM-GZ8-RT2-	28.8(1.13)	16.2(0.64)	16.0(0.63)	14.3(0.56)	4.8(0.19)	9.7(0.38)	19.8(0.78)
8	1/4	FYM-GZ8-RT4-	28.8(1.13)	16.2(0.64)	16.0(0.63)	14.3(0.56)	6.4(0.25)	14.2(0.56)	24.4(0.96)
8	3/8	FYM-GZ8-RT6-	30.6(1.20)	16.2(0.64)	16.0(0.63)	17.5(0.69)	6.4(0.25)	14.2(0.56)	26.2(1.03)
8	1/2	FYM-GZ8-RT8-	32.6(1.28)	16.2(0.64)	16.0(0.63)	20.6(0.81)	6.4(0.25)	19.1(0.75)	33.0(1.30)
10	1/8	FYM-GZ10-RT2-	31.5(1.24)	17.2(0.68)	19.0(0.75)	17.5(0.69)	4.8(0.19)	9.7(0.38)	21.6(0.85)
10	1/4	FYM-GZ10-RT4-	31.5(1.24)	17.2(0.68)	19.0(0.75)	17.5(0.69)	7.1(0.28)	14.2(0.56)	26.2(1.03)
10	3/8	FYM-GZ10-RT6-	31.5(1.24)	17.2(0.68)	19.0(0.75)	17.5(0.69)	7.9(0.31)	14.2(0.56)	26.2(1.03)
10	1/2	FYM-GZ10-RT8-	33.5(1.32)	17.2(0.68)	19.0(0.75)	20.6(0.81)	7.9(0.31)	19.1(0.75)	33.0(1.30)
12	1/8	FYM-GZ12-RT2-	36.0(1.42)	22.8(0.90)	22.0(0.87)	20.6(0.81)	4.8(0.19)	9.7(0.38)	23.6(0.93)
12	1/4	FYM-GZ12-RT4-	36.0(1.42)	22.8(0.90)	22.0(0.87)	20.6(0.81)	7.1(0.28)	14.2(0.56)	28.2(1.11)
12	3/8	FYM-GZ12-RT6-	36.0(1.42)	22.8(0.90)	22.0(0.87)	20.6(0.81)	9.5(0.37)	14.2(0.56)	28.2(1.11)
12	1/2	FYM-GZ12-RT8-	36.0(1.42)	22.8(0.90)	22.000.87	20.6(0.81)	9.5(0.37)	19.1(0.75)	33.0(1.30)
12	3/4	FYM-GZ12-RT12-	39.8(1.57)	22.8(0.90)	22.0(0.87)	27.0(1.06)	9.5(0.37)	19.1(0.75)	36.8(1.45)
14	1/2	FYM-GZ14-RT8-	38.1(1.50)	24.4(0.96)	25.0(0.98)	23.8(0.94)	11.1(0.44)	19.1(0.75)	35.1(1.38)
15	1/2	FYM-GZ15-RT8-	38.1(1.50)	24.4(0.96)	25.0(0.98)	23.8(0.94)	11.9(0.47)	19.1(0.75)	35.1(1.38)
16	1/4	FYM-GZ16-RT4-	38.0(1.50)	24.4(0.96)	25.0(0.98)	23.8(0.94)	7.1(0.28)	14.2(0.56)	30.2(1.19)
16	3/8	FYM-GZ16-RT6-	38.0(1.50)	24.4(0.96)	25.0(0.98)	23.8(0.94)	9.5(0.37)	14.2(0.56)	30.2(1.19)
16	1/2	FYM-GZ16-RT8-	38.0(1.50)	24.4(0.96)	25.0(0.98)	23.8(0.94)	11.9(0.47)	19.1(0.75)	35.1(1.38)
16	3/4	FYM-GZ16-RT12-	39.8(1.57)	24.4(0.96)	25.0(0.98)	27.0(1.06)	12.7(0.50)	19.1(0.75)	36.8(1.45)
18	1/2	FYM-GZ18-RT8-	39.8(1.57)	24.4(0.96)	30.0(1.18)	27.0(1.06)	11.9(0.47)	19.1(0.75)	36.8(1.45)
18	3/4	FYM-GZ18-RT12-	39.8(1.57)	24.4(0.96)	30.0(1.18)	27.0(1.06)	15.1(0.59)	19.1(0.75)	36.8(1.45)
20	1/2	FYM-GZ20-RT8-	44.6(1.76)	26.0(1.02)	32.0(1.26)	34.9(1.37)	11.9(0.47)	19.1(0.75)	41.7(1.64)
20	3/4	FYM-GZ20-RT12-	44.6(1.76)	26.0(1.02)	32.0(1.26)	34.9(1.37)	15.9(0.63)	19.1(0.75)	41.7(1.64)
22	3/4	FYM-GZ22-RT12-	44.6(1.76)	26.0(1.02)	32.0(1.26)	34.9(1.37)	15.9(0.63)	19.1(0.75)	41.7(1.64)
22	1	FYM-GZ22-RT16-	44.6(1.76)	26.0(1.02)	32.0(1.26)	34.9(1.37)	18.3(0.72)	23.9(0.94)	46.5(1.83)
25	3/4	FYM-GZ25-RT12-	49.1(1.93)	31.3(0.90)	38.0(1.50)	34.9(1.37)	15.9(0.63)	19.1(0.75)	41.7(1.64)
25	1	FYM-GZ25-RT16-	49.1(1.93)	31.3(0.90)	38.0(1.50)	34.9(1.37)	21.8(0.86)	23.9(0.94)	46.5(1.83)
28	1	FYM-GZ28-RT16-	64.0(2.52)	36.6(0.90)	46.0(1.81)	42.9(1.69)	21.8(0.86)	23.9(0.94)	53.1(2.09)

## Угольник 45° с наружной резьбой

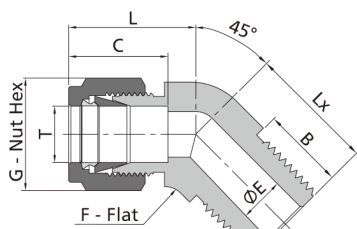

Размер E наименьший номинальный размер.

### Дюймовая трубка

### Резьба NPT

Т-Трубка. (дюймы)	P-NPT Резьба	Артикул	Размеры, дюймы. (мм)						
			L	C	G	F	E	B	Lx
1/16	1/16	FY45M-YZ1-NPT1-	0.82(20.8)	0.34(8.6)	0.31(7.9)	0.44(11.1)	0.05(1.3)	0.38(9.7)	0.66(16.8)
1/8	1/8	FY45M-YZ2-NPT2-	0.82(20.8)	0.50(12.7)	0.44(11.1)	0.44(11.1)	0.09(2.3)	0.38(9.7)	0.66(16.8)
3/16	1/8	FY45M-YZ3-NPT2-	0.85(21.6)	0.54(13.7)	0.50(12.7)	0.44(11.1)	0.12(3.0)	0.38(9.7)	0.58(14.7)
1/4	1/8	FY45M-YZ4-NPT2-	0.97(24.6)	0.60(15.2)	0.56(14.3)	0.50(12.7)	0.19(4.8)	0.38(9.7)	0.65(16.5)
1/4	1/4	FY45M-YZ4-NPT 4-	0.97(24.6)	0.60(15.2)	0.56(14.3)	0.50(12.7)	0.19(4.8)	0.56(14.2)	0.83(21.1)
5/16	1/8	FY45M-YZ5-NPT2-	0.94(24.0)	0.64(16.3)	0.63(15.9)	0.56(14.3)	0.19(4.8)	0.38(9.7)	0.66(16.8)
3/8	1/8	FY45M-YZ6-NPT2-	1.10(27.9)	0.66(16.8)	0.69(17.5)	0.63(15.9)	0.19(4.8)	0.38(9.7)	0.72(18.3)
3/8	1/4	FY45M-YZ6-NPT 4-	1.10(27.9)	0.66(16.8)	0.69(17.5)	0.63(15.9)	0.28(7.1)	0.56(14.2)	0.90(22.9)
3/8	3/8	FY45M-YZ6-NPT6-	1.15(29.2)	0.66(16.8)	0.69(17.5)	0.81(20.6)	0.28(7.1)	0.56(14.2)	0.95(24.1)
1/2	3/8	FY45M-YZ8-NPT6-	1.26(32.0)	0.90(22.9)	0.87(22.2)	0.81(20.6)	0.38(9.7)	0.56(14.2)	0.95(24.1)
5/8	1/2	FY45M-YZ10-NPT8-	1.20(30.4)	0.96(24.4)	1.00(25.4)	0.94(23.8)	0.47(11.9)	0.56(14.2)	1.17(29.7)
3/4	3/4	FY45M-YZ12-NPT12-	1.34(34.0)	0.96(24.4)	1.13(28.6)	1.06(27.0)	0.62(15.7)	0.75(19.1)	1.22(31.0)
7/8	3/4	FY45M-YZ14-NPT12-	1.59(40.4)	1.02(25.9)	1.25(31.8)	1.25(31.8)	0.62(15.7)	0.75(19.1)	1.27(32.3)
1	1	FY45M-YZ16-NPT16-	1.59(40.4)	1.23(31.2)	1.50(38.1)	1.37(34.9)	0.88(22.4)	0.94(23.9)	1.49(37.8)

### Метрическая трубка

### Резьба NPT

Т-Трубка. (дюймы)	P-NPT Резьба	Артикул	Размеры, дюймы. (мм)						
			L	C	G	F	E	B	Lx
6	1/8	FY45M-GZ6-NPT2-	23.4(0.92)	15.3(0.60)	14.0(0.55)	12.7(0.50)	4.8(0.19)	9.7(0.38)	16.8(0.66)
6	1/4	FY45M-GZ6-NPT4-	23.4(0.92)	15.3(0.60)	14.0(0.55)	12.7(0.50)	4.8(0.19)	14.2(0.56)	21.8(0.86)
8	1/8	FY45M-GZ8-NPT2-	24.3(0.96)	16.2(0.64)	16.0(0.63)	15.9(0.63)	4.8(0.19)	9.7(0.38)	16.8(0.66)
10	1/4	FY45M-GZ10-NPT4-	26.6(1.05)	17.2(0.68)	19.0(0.75)	17.5(0.69)	7.9(0.31)	14.2(0.56)	24.1(0.95)
12	3/8	FY45M-GZ12-NPT6-	29.1(1.15)	22.8(0.90)	22.0(0.87)	20.6(0.81)	9.5(0.37)	14.2(0.56)	24.1(0.95)
12	1/2	FY45M-GZ12-NPT8-	30.7(1.21)	22.8(0.90)	22.0(0.87)	20.6(0.81)	9.5(0.37)	19.1(0.75)	29.7(1.17)
16	1/2	FY45M-GZ16-NPT8-	30.4(1.20)	24.4(0.96)	25.0(0.98)	23.8(0.94)	11.9(0.47)	19.1(0.75)	29.7(1.17)

## Угольник с наружной резьбой и монтажной гайкой

Прямая резьба SAE/MS

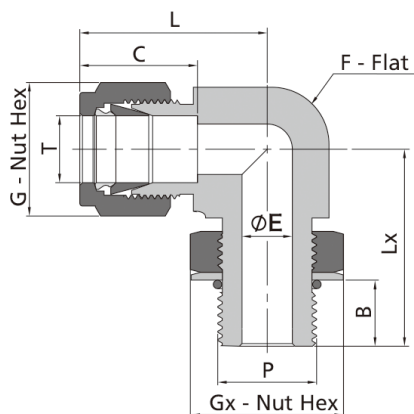

1. Размер E наименьший номинальный размер.

2. SAE J1926-1, ISO 11926-1 и MS 16142.

Дюймовая трубка				Прямая резьба SAE/MS							
T-Трубка (in.)	P-SAE размер	P-SAE/MS резьба	Артикул	Размеры, дюймы. (мм)							
				L	B	C	G	E	F	Lx	Gx
1/4	4	7/16-20	FYMN-YZ4-ST7-	1.12(28.4)	0.39(9.9)	0.60(15.2)	0.56(14.3)	0.19(4.8)	0.50(12.7)	1.06(27.0)	0.56(14.3)
1/4	6	9/16-18	FYMN-YZ4-ST9-	1.20(30.5)	0.44(11.2)	0.60(15.2)	0.56(14.3)	0.19(4.8)	0.63(15.9)	1.27(32.3)	0.69(17.5)
5/16	5	1/2-20	FYMN-YZ5-ST8-	1.19(30.2)	0.39(9.9)	0.64(16.3)	0.63(15.9)	0.23(5.8)	0.56(14.3)	1.16(29.5)	0.63(15.9)
3/8	4	7/16-20	FYMN-YZ6-ST7-	1.31(33.3)	0.39(9.9)	0.66(16.8)	0.69(17.5)	0.20(5.1)	0.63(15.9)	1.24(31.5)	0.56(14.3)
3/8	6	9/16-18	FYMN-YZ6-ST9-	1.26(32.0)	0.44(11.2)	0.66(16.8)	0.69(17.5)	0.28(7.1)	0.63(15.9)	1.27(32.3)	0.69(17.5)
3/8	8	3/4-16	FYMN-YZ6-ST12-	1.37(34.8)	0.50(12.7)	0.66(16.8)	0.69(17.5)	0.28(7.1)	0.81(20.6)	1.49(37.8)	0.87(22.2)
1/2	6	9/16-18	FYMN-YZ8-ST9-	1.48(37.6)	0.44(11.2)	0.90(22.9)	0.87(22.2)	0.28(7.1)	0.81(20.6)	1.48(37.5)	0.69(17.5)
1/2	8	3/4-16	FYMN-YZ8-ST12-	1.48(37.6)	0.50(12.7)	0.90(22.9)	0.87(22.2)	0.41(10.4)	0.81(20.6)	1.49(37.8)	0.87(22.2)
5/8	10	7/8-14	FYMN-YZ10-ST14-	1.56(39.6)	0.56(14.2)	0.96(24.4)	1.00(25.4)	0.50(12.7)	0.94(23.8)	1.71(43.4)	1.00(25.4)
3/4	12	1 1/16-12	FYMN-YZ12-ST17-	1.63(41.4)	0.66(16.8)	0.96(24.4)	1.13(28.6)	0.62(15.7)	1.06(27.0)	1.92(48.8)	1.25(31.8)
7/8	14	1 3/16-12	FYMN-YZ14-ST19-	1.70(43.2)	0.66(16.8)	1.02(25.9)	1.25(31.8)	0.72(18.3)	1.25(31.8)	1.99(50.5)	1.37(34.9)
1	16	1 5/16-12	FYMN-YZ16-ST21-	1.99(50.5)	0.66(16.8)	1.23(31.2)	1.50(38.1)	0.88(22.4)	1.37(34.9)	2.11(53.6)	1.50(38.1)
1 1/4	20	1 5/8-12	FYMN-YZ20-ST26-	2.67(67.8)	0.66(16.8)	1.62(41.1)	1.87(47.6)	1.09(27.7)	1.69(42.9)	2.29(58.2)	1.87(47.6)
1 1/2	24	1 7/8-12	FYMN-YZ24-ST30-	3.07(78.0)	0.66(16.8)	1.97(50.0)	2.25(57.2)	1.34(34.0)	2.00(50.8)	2.38(60.5)	2.13(54.0)

## Угольник с наружной резьбой и монтажной гайкой

Цилиндрическая резьба ISO

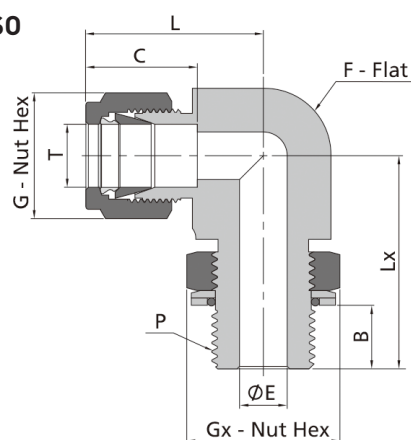

Размер E наименьший номинальный размер.

### Дюймовая трубка Цилиндрическая резьба ISO (PR)

Т-Трубка. (дюймы)	P-ISO Резьба	Артикул	Размеры, дюймы. (мм)							
			L	B	C	G	E	F	Lx	Gx
1/4	1/8	FYMN-YZ4-PR2-	1.06(26.9)	0.26(6.6)	0.60(15.2)	0.56(14.3)	0.16(4.1)	0.50(12.7)	1.04(26.4)	0.56(14.3)
1/4	1/4	FYMN-YZ4-PR4-	1.14(29.0)	0.35(9.0)	0.60(15.2)	0.56(14.3)	0.19(4.8)	0.63(15.9)	1.27(32.3)	0.75(19.1)
3/8	1/4	FYMN-YZ6-PR4-	1.20(30.5)	0.35(9.0)	0.66(16.8)	0.69(17.5)	0.23(5.8)	0.63(15.9)	1.27(32.3)	0.75(19.1)
3/8	3/18	FYMN-YZ6-PR6-	1.31(33.3)	0.37(9.4)	0.66(16.8)	0.69(17.5)	0.28(7.1)	0.81(20.6)	1.46(37.1)	0.87(22.2)
1/2	1/4	FYMN-YZ8-PR4-	1.42(36.1)	0.35(9.0)	0.90(22.9)	0.87(22.2)	0.23(5.8)	0.81(20.6)	1.38(35.1)	0.75(19.1)
1/2	3/8	FYMN-YZ8-PR6-	1.42(36.1)	0.37(9.4)	0.90(22.9)	0.87(22.2)	0.31(7.9)	0.81(20.6)	1.46(37.1)	0.87(22.2)
1/2	1/2	FYMN-YZ8-PR8-	1.50(38.1)	0.51(13.0)	0.90(22.9)	0.87(22.2)	0.41(10.4)	0.94(23.8)	1.71(43.4)	1.06(27.0)
5/8	1/2	FYMN-YZ10-PR8-	1.50(38.1)	0.51(13.0)	0.96(24.4)	1.00(25.4)	0.47(11.9)	0.94(23.8)	1.71(43.4)	1.06(27.0)
3/4	1/2	FYMN-YZ12-PR8-	1.57(39.9)	0.51(13.0)	0.96(24.4)	1.13(28.6)	0.47(11.9)	1.06(27.0)	1.78(45.2)	1.06(27.0)
3/4	3/4	FYMN-YZ12-PR12-	1.57(39.9)	0.51(13.0)	0.96(24.4)	1.13(28.6)	0.62(15.7)	1.06(27.0)	1.92(48.8)	1.37(34.9)
1	3/4	FYMN-YZ16-PR12-	1.93(49.0)	0.51(13.0)	1.23(31.2)	1.50(38.1)	0.62(15.7)	1.37(34.9)	2.10(53.3)	1.37(34.9)
1	1	FYMN-YZ16-PR16-	1.93(49.0)	0.52(13.2)	1.23(31.2)	1.50(38.1)	0.78(19.8)	1.37(34.9)	2.11(53.6)	1.63(41.3)

### Metric Tube

### Цилиндрическая резьба ISO (PR)

Т-Трубка. (мм.)	P-ISO Резьба	Артикул	Размеры, дюймы. (мм)							
			L	B	C	G	E	F	Lx	Gx
6	1/8	FYMN-GZ6-PR2-	27.0(1.06)	6.6(0.26)	15.3(0.60)	14.0(0.55)	4.0(0.16)	12.7(0.50)	26.4(1.04)	14.3(0.56)
6	1/4	FYMN-GZ6-PR4-	29.0(1.14)	9.0(0.35)	15.3(0.60)	14.0(0.55)	4.8(0.19)	15.9(0.63)	32.3(1.27)	19.1(0.75)
8	1/8	FYMN-GZ8-PR2-	28.8(1.13)	6.6(0.26)	16.2(0.64)	16.0(0.63)	4.0(0.16)	14.3(0.56)	27.4(1.08)	14.3(0.56)
8	1/4	FYMN-GZ8-PR4-	29.9(1.18)	9.0(0.35)	16.2(0.64)	16.0(0.63)	5.9(0.23)	15.9(0.63)	32.2(1.27)	19.1(0.75)
10	1/4	FYMN-GZ10-PR4-	33.5(1.32)	9.0(0.35)	17.2(0.68)	19.0(0.75)	5.9(0.23)	20.6(0.81)	35.0(1.38)	19.1(0.75)
10	3/18	FYMN-GZ10-PR6-	33.5(1.32)	9.4(0.37)	17.2(0.68)	19.0(0.75)	7.9(0.31)	20.6(0.81)	37.1(1.46)	22.2(0.87)
12	1/4	FYMN-GZ12-PR4-	36.0(1.42)	9.0(0.35)	22.8(0.90)	22.0(0.87)	5.9(0.23)	20.6(0.81)	35.0(1.38)	19.1(0.75)
12	3/18	FYMN-GZ12-PR6-	36.0(1.42)	9.4(0.37)	22.8(0.90)	22.0(0.87)	7.9(0.31)	20.6(0.81)	37.1(1.46)	22.2(0.87)
12	1/2	FYMN-GZ12-PR8-	38.0(1.50)	13.0(0.51)	22.8(0.90)	22.0(0.87)	9.5(0.37)	23.8(0.94)	43.4(1.71)	27.0(1.06)
12	3/4	FYMN-GZ12-PR12-	39.8(1.57)	13.0(0.51)	22.8(0.90)	22.0(0.87)	9.5(0.37)	27.0(1.06)	48.8(1.92)	34.9(1.37)

# Размеры

## Угольник 45° с наружной резьбой и монтажной гайкой

Прямая резьба SAE/MS

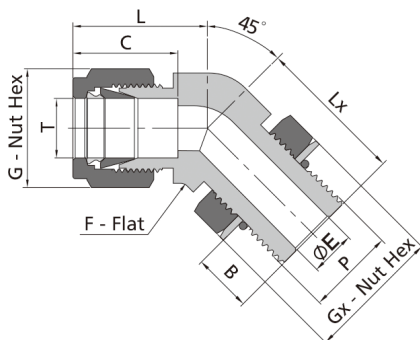

1. Размер E наименьший номинальный размер.
2. SAE J1926-1, ISO 11926-1 и MS 16142.

### Дюймовая трубка

### Прямая резьба SAE/MS

Т-Трубка (in.)	P-SAE размер	P-SAE/MS резьба	Артикул	Размеры, дюймы. (мм)							
				L	B	C	G	E	F	Lx	Gx
1/4	4	7/16-20	FY45MN-YZ4-ST7-	1.01(25.7)	0.39(9.9)	0.60(15.2)	0.56(14.3)	0.19(4.8)	0.50(12.7)	1.01(25.7)	0.56(14.3)
3/8	6	9/16-18	FY45MN-YZ6-ST9-	1.10(27.9)	0.44(11.2)	0.66(16.8)	0.69(17.5)	0.28(7.1)	0.63(15.9)	1.11(28.2)	0.69(17.5)
1/2	8	3/4-16	FY45MN-YZ8-ST12-	1.26(32.0)	0.50(12.7)	0.90(22.9)	0.87(22.2)	0.41(10.4)	0.81(20.6)	1.27(32.3)	0.87(22.2)
3/4	12	1 1/16-12	FY45MN-YZ12-ST17-	1.57(39.9)	0.66(16.8)	0.96(24.4)	1.13(28.6)	0.62(15.7)	1.06(27.0)	1.86(47.2)	1.25(31.8)
1	16	1 5/16-12	FY45MN-YZ16-ST21-	1.87(47.5)	0.66(16.8)	1.23(31.2)	1.50(38.1)	0.88(22.4)	1.37(34.9)	1.99(50.5)	1.50(38.1)

## Угольник с внутренней резьбой

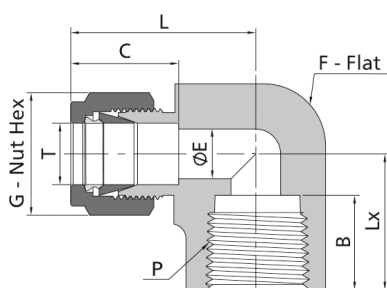

Дюймовая трубка			Резьба NPT						
Т-Трубка (in.)	Р-NPT Резьба	Артикул	Размеры, дюймы. (мм)						
			L	B	C	G	E	F	Lx
1/16	1/16	FYW-YZ1-NPT1-	0.71(18.0)	0.39(9.9)	0.34(8.6)	0.31(7.9)	0.05(1.3)	0.44(11.1)	0.56(14.2)
1/16	1/8	FYW-YZ1-NPT2-	0.81(20.6)	0.41(10.4)	0.34(8.6)	0.31(7.9)	0.05(1.3)	0.56(14.3)	0.75(19.1)
1/8	1/8	FYW-YZ2-NPT2-	0.97(24.6)	0.41(10.4)	0.50(12.7)	0.44(11.1)	0.09(2.3)	0.50(12.7)	0.75(19.1)
1/8	1/4	FYW-YZ2-NPT4-	1.08(27.4)	0.59(15.0)	0.50(12.7)	0.44(11.1)	0.09(2.3)	0.69(17.5)	0.88(22.4)
3/16	1/8	FYW-YZ3-NPT2-	1.00(25.4)	0.41(10.4)	0.54(13.7)	0.50(12.7)	0.12(3.0)	0.5(12.7)	0.75(19.1)
1/4	1/8	FYW-YZ4-NPT2-	1.06(26.9)	0.41(10.4)	0.60(15.2)	0.56(14.3)	0.19(4.8)	0.50(12.7)	0.75(19.1)
1/4	1/4	FYW-YZ4-NPT4-	1.17(29.7)	0.59(15.0)	0.60(15.2)	0.56(14.3)	0.19(4.8)	0.69(17.5)	0.88(22.4)
1/4	3/8	FYW-YZ4-NPT6-	1.25(31.8)	0.59(15.0)	0.60(15.2)	0.56(14.3)	0.19(4.8)	0.81(20.6)	0.88(22.4)
1/4	1/2	FYW-YZ4-NPT8-	1.36(34.5)	0.78(19.8)	0.60(15.2)	0.56(14.3)	0.19(4.8)	1.00(25.4)	1.12(28.4)
5/16	1/8	FYW-YZ5-NPT2-	1.13(28.7)	0.41(10.4)	0.64(16.3)	0.63(15.9)	0.25(6.4)	0.56(14.3)	0.75(19.1)
5/16	1/4	FYW-YZ5-NPT4-	1.20(30.5)	0.59(15.0)	0.64(16.3)	0.63(15.9)	0.25(6.4)	0.69(17.5)	0.88(22.4)
3/8	1/8	FYW-YZ6-NPT2-	1.20(30.5)	0.41(10.4)	0.66(16.8)	0.69(17.5)	0.28(7.1)	0.63(15.9)	0.75(19.1)
3/8	1/4	FYW-YZ6-NPT4-	1.23(31.2)	0.59(15.0)	0.66(16.8)	0.69(17.5)	0.28(7.1)	0.69(17.5)	0.88(22.4)
3/8	3/8	FYW-YZ6-NPT6-	1.31(33.3)	0.59(15.0)	0.66(16.8)	0.69(17.5)	0.28(7.1)	0.81(20.6)	0.88(22.4)
3/8	1/2	FYW-YZ6-NPT8-	1.42(36.1)	0.78(19.8)	0.66(16.8)	0.69(17.5)	0.28(7.1)	1.00(25.4)	1.12(28.4)
1/2	1/4	FYW-YZ8-NPT4-	1.42(36.1)	0.59(15.0)	0.90(22.9)	0.87(22.2)	0.41(10.4)	0.81(20.6)	0.88(22.4)
1/2	3/8	FYW-YZ8-NPT6-	1.42(36.1)	0.59(15.0)	0.90(22.9)	0.87(22.2)	0.41(10.4)	0.81(20.6)	0.88(22.4)
1/2	1/2	FYW-YZ8-NPT8-	1.53(38.9)	0.78(19.8)	0.90(22.9)	0.87(22.2)	0.41(10.4)	1.00(25.4)	1.12(28.4)
5/8	3/8	FYW-YZ10-NPT6-	1.50(38.1)	0.59(15.0)	0.96(24.4)	1.00(25.4)	0.50(12.7)	0.94(23.8)	0.88(22.4)
5/8	1/2	FYW-YZ10-NPT8-	1.57(39.9)	0.78(19.8)	0.96(24.4)	1.00(25.4)	0.50(12.7)	1.06(27.0)	1.12(28.4)
3/4	1/2	FYW-YZ12-NPT8-	1.57(39.9)	0.78(19.8)	0.96(24.4)	1.13(28.6)	0.62(15.7)	1.06(27.0)	1.12(28.4)
3/4	3/4	FYW-YZ12-NPT12-	1.76(44.7)	0.81(20.6)	0.96(24.4)	1.13(28.6)	0.62(15.7)	1.37(34.9)	1.25(31.8)
7/8	3/4	FYW-YZ14-NPT12-	1.76(44.7)	0.81(20.6)	1.02(25.9)	1.25(31.8)	0.72(18.3)	1.37(34.9)	1.25(31.8)
1	3/4	FYW-YZ16-NPT12-	1.93(49.0)	0.81(20.6)	1.23(31.2)	1.50(38.1)	0.88(22.4)	1.37(34.9)	1.25(31.8)
1	1	FYW-YZ16-NPT16-	2.11(53.6)	1.00(25.4)	1.23(31.2)	1.50(38.1)	0.88(22.4)	1.69(42.9)	1.50(38.1)

Метрическая трубка			Резьба NPT						
Т-Трубка (in.)	Р-NPT Резьба	Артикул	Размеры, дюймы. (мм)						
			L	B	C	G	E	F	Lx
6	1/8	FYW-GZ6-NPT2-	27.0(1.06)	10.4(0.41)	15.3(0.60)	14.0(0.55)	4.8(0.19)	12.7(0.50)	19.0(0.75)
6	1/4	FYW-GZ6-NPT4-	29.8(1.17)	15.0(0.59)	15.3(0.60)	14.0(0.55)	4.8(0.19)	17.5(0.69)	22.4(0.88)
8	1/8	FYW-GZ8-NPT2-	28.8(1.13)	10.4(0.41)	16.2(0.64)	16.0(0.63)	6.4(0.25)	14.3(0.56)	19.1(0.75)
8	1/4	FYW-GZ8-NPT4-	30.6(1.20)	15.0(0.59)	16.2(0.64)	16.0(0.63)	6.4(0.25)	17.5(0.69)	22.4(0.88)
10	1/4	FYW-GZ10-NPT4-	33.5(1.32)	15.0(0.59)	17.2(0.68)	19.0(0.75)	7.9(0.31)	20.6(0.81)	22.4(0.88)
10	3/8	FYW-GZ10-NPT6-	33.5(1.32)	15.0(0.59)	17.2(0.68)	19.0(0.75)	7.9(0.31)	20.6(0.81)	22.4(0.88)
10	1/2	FYW-GZ10-NPT8-	36.6(1.44)	19.8(0.78)	17.2(0.68)	19.0(0.75)	7.9(0.31)	25.4(1.00)	28.5(1.12)
12	1/4	FYW-GZ12-NPT4-	36.0(1.42)	15.0(0.59)	22.8(0.90)	22.0(0.87)	9.5(0.37)	20.6(0.81)	22.4(0.88)
12	3/8	FYW-GZ12-NPT6-	36.0(1.42)	15.0(0.59)	22.8(0.90)	22.0(0.87)	9.5(0.37)	20.6(0.81)	22.4(0.88)
12	1/2	FYW-GZ12-NPT8-	38.8(1.53)	19.8(0.78)	22.8(0.90)	22.0(0.87)	9.5(0.37)	25.4(1.00)	28.4(1.12)
16	3/8	FYW-GZ16-NPT6-	39.5(1.56)	15.0(0.59)	24.4(0.96)	25.0(0.98)	12.7(0.50)	27.0(1.06)	23.6(0.93)
16	1/2	FYW-GZ16-NPT8-	39.5(1.56)	19.8(0.78)	24.4(0.96)	25.0(0.98)	12.7(0.50)	27.0(1.06)	28.5(1.12)

## Угольник проходной

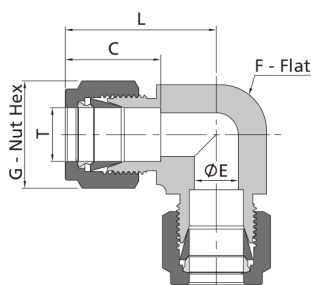

### Дюймовая трубка

Т-Трубка (in.)	Артикул	Размеры, дюймы. (мм)				
		L	C	G	F	E
1/16	FYP-YZ1-	0.70(17.8)	0.34(8.6)	0.31(7.9)	0.37(9.5)	0.05(1.3)
1/8	FYP-YZ2-	0.88(22.4)	0.50(12.7)	0.44(11.1)	0.37(9.5)	0.09(2.3)
3/16	FYP-YZ3-	1.00(25.4)	0.54(13.7)	0.50(12.7)	0.50(12.7)	0.12(3.0)
1/4	FYP-YZ4-	1.06(26.9)	0.60(15.2)	0.56(14.3)	0.50(12.7)	0.19(4.8)
5/16	FYP-YZ5-	1.13(28.7)	0.64(16.3)	0.63(15.9)	0.56(14.3)	0.25(6.4)
3/8	FYP-YZ6-	1.20(30.5)	0.66(16.8)	0.69(17.5)	0.63(15.9)	0.28(7.1)
1/2	FYP-YZ8-	1.42(36.1)	0.90(22.9)	0.87(22.2)	0.81(20.6)	0.41(10.4)
5/8	FYP-YZ10-	1.50(38.1)	0.96(24.4)	1.00(25.4)	0.94(23.8)	0.5(12.7)
3/4	FYP-YZ12-	1.57(39.9)	0.96(24.4)	1.13(28.6)	1.06(27.0)	0.62(15.7)
7/8	FYP-YZ14-	1.76(44.7)	1.02(25.9)	1.25(31.8)	1.37(34.9)	0.72(18.3)
1	FYP-YZ16-	1.93(49.0)	1.23(31.2)	1.50(38.1)	1.37(34.9)	0.88(22.4)
1 1/8	FYP-YZ18-	2.63(66.9)	1.44(36.7)	1.75(44.5)	1.69(42.9)	0.97(24.6)
1 1/4	FYP-YZ20-	2.62(66.5)	1.62(41.1)	1.87(47.6)	1.69(42.9)	1.09(27.7)
1 1/2	FYP-YZ24-	3.07(78.0)	1.97(50.0)	2.25(57.2)	2.00(50.8)	1.34(34.0)

### Metric Tube

Т-Трубка (мм.)	Артикул	Размеры, дюймы. (мм)				
		L	C	G	F	E
3	FYP-GZ3-	22.3(0.88)	12.9(0.51)	12.0(0.47)	9.5(0.37)	2.4(0.09)
4	FYP-GZ4-	25.4(1.00)	13.7(0.54)	12.0(0.47)	12.7(0.50)	2.4(0.09)
6	FYP-GZ6-	27.0(1.06)	15.3(0.60)	14.0(0.55)	12.7(0.50)	4.8(0.19)
8	FYP-GZ8-	28.8(1.13)	16.2(0.64)	16.0(0.63)	14.3(0.56)	6.4(0.25)
10	FYP-GZ10-	31.5(1.24)	17.2(0.68)	19.0(0.75)	17.5(0.69)	7.9(0.31)
12	FYP-GZ12-	36.0(1.42)	22.8(0.90)	22.0(0.87)	20.6(0.81)	9.5(0.37)
14	FYP-GZ14-	38.0(1.50)	24.4(0.96)	25.0(0.98)	23.8(0.94)	11.0(0.43)
15	FYP-GZ15-	38.0(1.50)	24.4(0.96)	25.0(0.98)	23.8(0.94)	11.9(0.47)
16	FYP-GZ16-	38.0(1.50)	24.4(0.96)	25.0(0.98)	23.8(0.94)	12.7(0.50)
18	FYP-GZ18-	39.8(1.57)	24.4(0.96)	30.0(1.18)	27.0(1.06)	15.1(0.59)
20	FYP-GZ20-	44.6(1.76)	26.0(1.02)	32.0(1.26)	34.9(1.37)	15.9(0.63)
22	FYP-GZ22-	44.6(1.76)	26.0(1.02)	32.0(1.26)	34.9(1.37)	18.3(0.72)
25	FYP-GZ25-	49.1(1.93)	31.3(1.23)	38.0(1.5)	34.9(1.37)	21.8(0.86)
28	FYP-GZ28-	64.0(2.52)	36.6(1.44)	46.0(1.81)	42.9(1.69)	21.8(0.86)
30	FYP-GZ30-	69.9(2.75)	39.6(1.56)	50.0(1.97)	42.9(1.69)	26.2(1.03)
32	FYP-GZ32-	72.3(2.85)	42.0(1.65)	50.0(1.97)	42.9(1.69)	28.6(1.13)
38	FYP-GZ38-	84.0(3.31)	49.4(1.94)	60.0(2.36)	50.8(2.00)	33.7(1.33)



## Угольник переходной

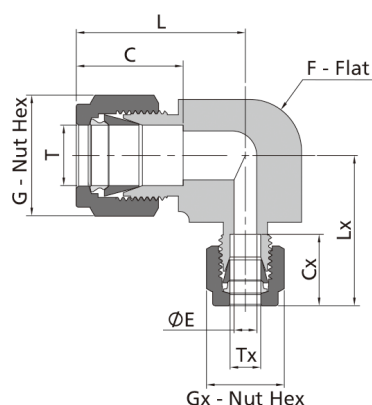

### Fractional Tube

Т-Трубка (дюймы)	Тх- Трубка. (дюймы)	Артикул	Размеры, дюймы. (мм)							
			L	C	G	F	E	Cx	Gx	Lx
3/16	1/8	FYR-YZ3-YZ2-	1.00(25.4)	0.54(13.7)	0.50(12.7)	0.50(12.7)	0.09(2.3)	0.50(12.7)	0.44(11.1)	0.97(24.7)
1/4	1/8	FYR-YZ4-YZ2-	1.06(26.9)	0.60(15.2)	0.56(14.3)	0.50(12.7)	0.09(2.3)	0.50(12.7)	0.44(11.1)	1.00(25.4)
5/16	1/8	FYR-YZ5-YZ2-	1.17(29.7)	0.64(16.3)	0.63(15.9)	0.56(14.3)	0.09(2.3)	0.50(12.7)	0.44(11.1)	1.04(26.4)
5/16	1/4	FYR-YZ5-YZ4-	1.17(29.7)	0.64(16.3)	0.63(15.9)	0.56(14.3)	0.19(4.8)	0.60(15.2)	0.56(14.3)	1.14(29.0)
3/8	1/8	FYR-YZ6-YZ2-	1.20(30.5)	0.66(16.8)	0.69(17.5)	0.63(15.9)	0.09(2.3)	0.50(12.7)	0.44(11.1)	1.04(26.4)
3/8	1/4	FYR-YZ6-YZ4-	1.20(30.5)	0.66(16.8)	0.69(17.5)	0.63(15.9)	0.19(4.8)	0.60(15.2)	0.56(14.3)	1.14(29.0)
3/8	5/16	FYR-YZ6-YZ5-	1.20(30.5)	0.66(16.8)	0.69(17.5)	0.63(15.9)	0.25(6.4)	0.64(16.3)	0.63(15.9)	1.17(29.7)
1/2	1/4	FYR-YZ8-YZ4-	1.42(36.1)	0.90(22.9)	0.87(22.2)	0.81(20.6)	0.19(4.8)	0.60(15.2)	0.56(14.3)	1.27(32.2)
1/2	5/16	FYR-YZ8-YZ5-	1.42(36.1)	0.90(22.9)	0.87(22.2)	0.81(20.6)	0.25(6.4)	0.64(16.3)	0.63(15.9)	1.28(32.5)
1/2	3/8	FYR-YZ8-YZ6-	1.42(36.1)	0.90(22.9)	0.87(22.2)	0.81(20.6)	0.28(7.1)	0.66(16.8)	0.69(17.5)	1.32(33.6)
5/8	3/8	FYR-YZ1 0-YZ6-	1.50(38.1)	0.96(24.4)	1.00(25.4)	0.94(23.8)	0.28(7.1)	0.66(16.8)	0.69(17.5)	1.40(35.6)
5/8	1/2	FYR-YZ10-YZ8-	1.50(38.1)	0.96(24.4)	1.00(25.4)	0.94(23.8)	0.41(10.4)	0.90(22.9)	0.87(22.2)	1.50(38.1)
3/4	1/4	FYR-YZ12-YZ4-	1.57(39.9)	0.96(24.4)	1.13(28.6)	1.06(27.0)	0.19(4.8)	0.60(15.2)	0.56(14.3)	1.41(35.9)
3/4	3/8	FYR-YZ12-YZ6-	1.57(39.9)	0.96(24.4)	1.13(28.6)	1.06(27.0)	0.28(7.1)	0.66(16.8)	0.69(17.5)	1.47(37.4)
3/4	1/2	FYR-YZ12-YZ8-	1.57(39.9)	0.96(24.4)	1.13(28.6)	1.06(27.0)	0.41(10.4)	0.90(22.9)	0.87(22.2)	1.57(39.9)
7/8	1/4	FYR-YZ14-YZ4-	1.76(44.7)	1.02(25.9)	1.25(31.8)	1.37(34.9)	0.19(4.8)	0.60(15.2)	0.56(14.3)	1.60(40.7)
1	1/2	FYR-YZ16-YZ8-	1.93(49.0)	1.23(31.2)	1.50(38.1)	1.37(34.9)	0.41(10.4)	0.90(22.9)	0.87(22.2)	1.75(44.4)
1	3/4	FYR-YZ16-YZ12-	1.93(49.0)	1.23(31.2)	1.50(38.1)	1.37(34.9)	0.62(15.7)	0.96(24.4)	1.13(28.6)	1.85(47.1)

### Метрическая трубка

Т-Трубка (мм.)	Тх- Трубка. (мм.)	Артикул	Размеры, дюймы. (мм)							
			L	C	G	F	E	Cx	Gx	Lx
8	6	FYR-GZ8-GZ6-	28.8(1.13)	16.2(0.64)	16.0(0.63)	14.3(0.56)	4.8(0.19)	15.3(0.60)	14.0(0.55)	27.9(1.10)
10	8	FYR-GZ10-GZ8-	31.5(1.24)	17.2(0.68)	19.0(0.75)	17.5(0.69)	6.4(0.25)	16.2(0.64)	16.0(0.63)	30.5(1.20)
12	8	FYR-GZ12-GZ8-	36.0(1.42)	22.8(0.90)	22.0(0.87)	20.6(0.81)	6.4(0.25)	16.2(0.64)	16.0(0.63)	32.6(1.28)
14	8	FYR-GZ14-GZ8-	38.8(1.53)	24.4(0.96)	25.0(0.98)	23.8(0.94)	6.4(0.25)	16.2(0.64)	16.0(0.63)	34.7(1.37)
14	10	FYR-GZ14-GZ10-	38.8(1.53)	24.4(0.96)	25.0(0.98)	23.8(0.94)	7.9(0.31)	17.2(0.68)	19.0(0.75)	35.5(1.40)

## Угольник проходной с монтажной гайкой

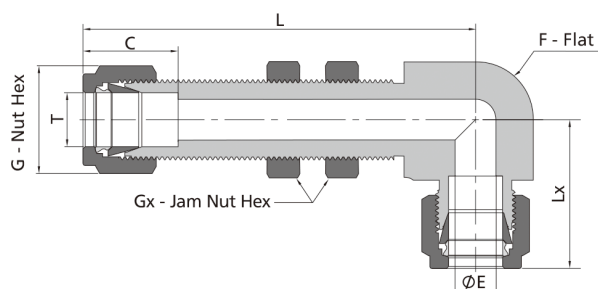

### Fractional Tube

Т-Трубка (in.)	Артикул	Размеры, дюймы. (мм)							Размер отверстия в панели дюймы. (мм)	Макс толщина панели дюймы. (мм)
		L	C	E	G	F	Lx	Gx		
1/8	FYPN-YZ2-	1.93(49.0)	0.50(12.7)	0.09(2.3)	0.44(11.1)	0.37(9.5)	0.88(22.4)	0.50(12.7)	0.33(8.3)	0.60(15.2)
3/16	FYPN-YZ3-	2.03(51.6)	0.54(13.7)	0.12(3.0)	0.50(12.7)	0.50(12.7)	1.00(25.4)	0.56(14.3)	0.39(9.9)	0.61(15.5)
1/4	FYPN-YZ4-	2.10(53.3)	0.60(15.2)	0.19(4.8)	0.56(14.3)	0.50(12.7)	1.06(26.9)	0.63(15.9)	0.45(11.5)	0.61(15.5)
5/6	FYPN-YZ5-	2.30(58.4)	0.64(16.3)	0.25(6.4)	0.63(15.9)	0.63(15.9)	1.13(28.7)	0.69(17.5)	0.52(13.1)	0.74(18.8)
3/8	FYPN-YZ6-	2.36(59.9)	0.66(16.8)	0.28(7.1)	0.69(15.7)	0.63(15.9)	1.20(30.5)	0.75(19.1)	0.58(14.7)	0.74(18.8)
1/2	FYPN-YZ8-	2.67(67.8)	0.90(22.9)	0.41(10.4)	0.87(22.2)	0.81(20.6)	1.42(36.1)	0.94(23.8)	0.76(19.4)	0.74(18.8)
5/8	FYPN-YZ10-	2.82(71.6)	0.96(24.4)	0.50(12.7)	1.00(25.4)	0.94(23.8)	1.50(38.1)	1.06(27.0)	0.89(22.6)	0.50(12.7)
3/4	FYPN-YZ12-	3.08(78.2)	0.96(24.4)	0.62(12.7)	1.13(28.6)	1.06(27.0)	1.57(39.9)	1.19(30.2)	1.02(25.8)	0.66(16.8)

## Тройник ввертный с наружной резьбой

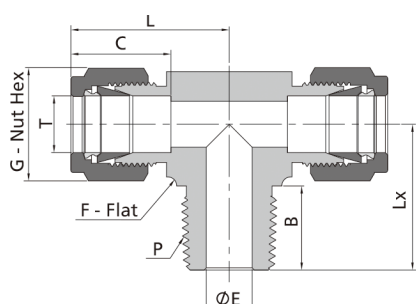

Размер E наименьший номинальный размер.

Дюймовая трубка			Резьба NPT						
Т-Трубка. (in.)	P-NPT Резьба	Артикул	Размеры, дюймы. (мм)						
			L	C	G	F	E	B	Lx
1/8	1/8	FTM-YZ2-NPT2-	0.93(23.6)	0.50(12.7)	0.44(11.1)	0.44(11.1)	0.09(2.3)	0.38(9.7)	0.70(17.8)
1/8	1/4	FTM-YZ2-NPT4-	0.97(24.6)	0.50(12.7)	0.44(11.1)	0.50(12.7)	0.09(2.3)	0.56(14.2)	0.92(23.4)
3/16	1/8	FTM-YZ3-NPT2-	0.96(24.4)	0.54(13.7)	0.50(12.7)	0.44(11.1)	0.12(3.0)	0.38(9.7)	0.70(17.8)
1/4	1/8	FTM-YZ4-NPT2-	1.06(26.9)	0.60(15.2)	0.56(14.3)	0.50(12.7)	0.19(4.8)	0.38(9.7)	0.74(18.8)
1/4	1/4	FTM-YZ4-NPT4-	1.06(26.9)	0.60(15.2)	0.56(14.3)	0.50(12.7)	0.19(4.8)	0.56(14.2)	0.92(23.4)
5/16	1/8	FTM-YZ5-NPT2-	1.17(29.7)	0.64(16.3)	0.63(15.9)	0.63(15.9)	0.19(4.8)	0.38(9.7)	0.82(20.8)
5/16	1/4	FTM-YZ5-NPT4-	1.17(29.7)	0.64(16.3)	0.63(15.9)	0.63(15.9)	0.25(6.4)	0.56(14.2)	1.01(25.7)
3/8	1/4	FTM-YZ6-NPT4-	1.20(30.5)	0.66(16.8)	0.69(17.5)	0.63(15.9)	0.28(7.1)	0.56(14.2)	1.00(25.4)
3/8	3/8	FTM-YZ6-NPT6-	1.31(33.3)	0.66(16.8)	0.69(17.5)	0.81(20.6)	0.28(7.1)	0.56(14.2)	1.11(28.2)
1/2	3/8	FTM-YZ8-NPT6-	1.42(36.1)	0.90(22.9)	0.87(22.2)	0.81(20.6)	0.38(9.7)	0.56(14.2)	1.11(28.2)
1/2	1/2	FTM-YZ8-NPT8-	1.42(36.1)	0.90(22.9)	0.87(22.2)	0.81(20.6)	0.41(10.4)	0.75(19.1)	1.30(33.0)
5/8	1/2	FTM-YZ10-NPT8-	1.53(38.9)	0.96(24.4)	1.00(25.4)	1.00(25.4)	0.47(11.9)	0.75(19.1)	1.41(35.8)
3/4	3/4	FTM-YZ12-NPT12-	1.57(39.9)	0.96(24.4)	1.13(28.6)	1.06(27.0)	0.62(15.7)	0.75(19.1)	1.45(36.8)
7/8	3/4	FTM-YZ14-NPT12-	1.88(47.8)	1.02(25.9)	1.25(31.8)	1.37(34.9)	0.62(15.7)	0.75(19.1)	1.87(47.5)
1	3/4	FTM-YZ16-NPT12-	1.94(49.3)	1.23(31.2)	1.50(38.1)	1.37(34.9)	0.62(15.7)	0.75(19.1)	1.87(47.5)
1	1	FTM-YZ16-NPT16-	1.94(49.3)	1.23(31.2)	1.50(38.1)	1.37(34.9)	0.88(22.4)	0.94(23.9)	1.84(46.7)

Метрическая трубка			Резьба NPT						
Т-Трубка. (мм.)	P-NPT Резьба	Артикул	Размеры, дюймы. (мм)						
			L	C	G	F	E	B	Lx
6	1/8	FTM-GZ6-NPT2-	27.0(1.06)	15.3(0.60)	14.0(0.55)	12.7(0.50)	4.8(0.19)	9.7(0.38)	18.8(0.74)
6	1/4	FTM-GZ6-NPT4-	27.0(1.06)	15.3(0.60)	14.0(0.55)	12.7(0.50)	4.8(0.19)	14.2(0.56)	23.4(0.92)
8	1/8	FTM-GZ8-NPT2-	29.9(1.18)	16.2(0.64)	16.0(0.63)	15.9(0.63)	4.8(0.19)	9.7(0.38)	20.8(0.82)
8	1/4	FTM-GZ8-NPT4-	29.9(1.18)	16.2(0.64)	16.0(0.63)	15.9(0.63)	6.4(0.25)	14.2(0.56)	25.4(1.00)
10	1/4	FTM-GZ10-NPT4-	33.5(1.32)	17.2(0.68)	19.0(0.75)	20.6(0.81)	7.1(0.28)	14.2(0.56)	28.2(1.11)
10	3/8	FTM-GZ10-NPT6-	33.5(1.32)	17.2(0.68)	19.0(0.75)	20.6(0.81)	7.9(0.31)	14.2(0.56)	28.2(1.11)
12	1/4	FTM-GZ12-NPT4-	36.0(1.42)	22.8(0.90)	22.0(0.87)	20.6(0.81)	7.1(0.28)	14.2(0.56)	28.2(1.11)
12	3/8	FTM-GZ12-NPT6-	36.0(1.42)	22.8(0.90)	22.0(0.87)	20.6(0.81)	9.5(0.37)	14.2(0.56)	28.2(1.11)
12	1/2	FTM-GZ12-NPT8-	36.0(1.42)	22.8(0.90)	22.0(0.87)	20.6(0.81)	9.5(0.37)	19.1(0.75)	33.0(1.30)
16	1/2	FTM-GZ16-NPT8-	38.8(1.53)	24.4(0.96)	25.0(0.98)	25.4(1.00)	11.9(0.47)	19.1(0.75)	35.8(1.41)

## Тройник с боковым отводом с наружной резьбой

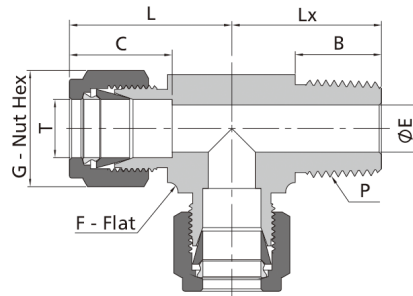

Размер E наименьший номинальный размер.

### Дюймовая трубка

### Резьба NPT

Т-Трубка. (in.)	P-NPT Резьба	Артикул	Размеры, дюймы. (мм)						
			L	C	G	F	E	B	Lx
1/8	1/8	FTSM-YZ2-NPT2-	0.93(23.6)	0.50(12.7)	0.44(11.1)	0.44(11.1)	0.09(2.3)	0.38(9.7)	0.70(17.8)
1/8	1/4	FTSM-YZ2-NPT4-	0.97(24.6)	0.50(12.7)	0.44(11.1)	0.50(12.7)	0.09(2.3)	0.56(14.2)	0.92(23.4)
3/16	1/8	FTSM-YZ3-NPT2-	0.96(24.4)	0.54(13.7)	0.50(12.7)	0.44(11.1)	0.12(3.0)	0.38(9.7)	0.70(17.8)
1/4	1/8	FTSM-YZ4-NPT2-	1.06(26.9)	0.60(15.2)	0.56(14.3)	0.50(12.7)	0.19(4.8)	0.38(9.7)	0.74(18.8)
1/4	1/4	FTSM-YZ4-NPT4 -	1.06(26.9)	0.60(15.2)	0.56(14.3)	0.50(12.7)	0.19(4.8)	0.56(14.2)	0.92(23.4)
5/16	1/8	FTSM-YZ5-NPT2-	1.17(29.7)	0.64(16.3)	0.63(15.9)	0.63(15.9)	0.19(4.8)	0.38(9.7)	0.82(20.8)
5/16	1/4	FTSM-YZ5-NPT4-	1.17(29.7)	0.64(16.3)	0.63(15.9)	0.63(15.9)	0.25(6.4)	0.56(14.2)	1.01(25.7)
3/8	1/4	FTSM-YZ6-NPT4-	1.20(30.5)	0.66(16.8)	0.69(17.5)	0.63(15.9)	0.28(7.1)	0.56(14.2)	1.00(25.4)
3/8	3/8	FTSM-YZ6-NPT6-	1.31(33.3)	0.66(16.8)	0.69(17.5)	0.81(20.6)	0.28(7.1)	0.56(14.2)	1.11(28.2)
1/2	3/8	FTSM-YZ8-NPT6-	1.42(36.1)	0.90(22.9)	0.87(22.2)	0.81(20.6)	0.38(9.7)	0.56(14.2)	1.11(28.2)
1/2	1/2	FTSM-YZ8-NPT8-	1.42(36.1)	0.90(22.9)	0.87(22.2)	0.81(20.6)	0.41(10.4)	0.75(19.1)	1.3(33.0)
5/8	1/2	FTSM-YZ10-NPT8-	1.50(38.1)	0.96(24.4)	1.00(25.4)	0.94(23.8)	0.47(11.9)	0.75(19.1)	1.41(35.8)
3/4	3/4	FTSM-YZ12-NPT12-	1.57(39.9)	0.96(24.4)	1.13(28.6)	1.06(27.0)	0.62(15.7)	0.75(19.1)	1.45(36.8)
7/8	3/4	FTSM-YZ14-NPT12-	1.88(47.8)	1.02(25.9)	1.25(31.8)	1.37(34.9)	0.62(15.7)	0.75(19.1)	1.87(47.5)
1	3/4	FTSM-YZ16-NPT12-	1.94(49.3)	1.23(31.2)	1.50(38.1)	1.37(34.9)	0.62(15.7)	0.75(19.1)	1.87(47.5)
1	1	FTSM-YZ16-NPT16-	1.94(49.3)	1.23(31.2)	1.50(38.1)	1.37(34.9)	0.88(22.4)	0.94(23.9)	1.84(46.7)

### Метрическая трубка

### Резьба NPT

Т-Трубка. (мм.)	P-NPT Резьба	Артикул	Размеры, дюймы. (мм)						
			L	C	G	F	E	B	Lx
6	1/8	FTSM-GZ6-NPT2-	27.0(1.06)	15.3(0.60)	14.0(0.55)	12.7(0.50)	4.8(0.19)	9.7(0.38)	18.0(0.71)
6	1/4	FTSM-GZ6-NPT4-	27.0(1.06)	15.3(0.60)	14.0(0.55)	12.7(0.50)	4.8(0.19)	14.2(0.56)	23.4(0.92)
8	1/8	FTSM-GZ8-NPT2-	29.9(1.18)	16.2(0.64)	16.0(0.63)	15.9(0.63)	4.8(0.19)	9.7(0.38)	20.8(0.82)
8	1/4	FTSM-GZ8-NPT4-	29.9(1.18)	16.2(0.64)	16.0(0.63)	15.9(0.63)	6.4(0.25)	14.2(0.56)	25.4(1.00)
10	1/4	FTSM-GZ10-NPT4-	33.5(1.32)	17.2(0.68)	19.0(0.75)	20.6(0.81)	7.1(0.28)	14.2(0.56)	28.2(1.11)
10	1/2	FTSM-GZ10-NPT8-	33.5(1.32)	17.2(0.68)	19.0(0.75)	20.6(0.81)	7.9(0.31)	19.1(0.75)	33.0(1.3)
12	1/4	FTSM-GZ12-NPT4-	36.0(1.42)	22.8(0.90)	22.0(0.87)	20.6(0.81)	7.1(0.28)	14.2(0.56)	28.2(1.11)
12	3/8	FTSM-GZ12-NPT6-	36.0(1.42)	22.8(0.90)	22.0(0.87)	20.6(0.81)	9.5(0.37)	14.2(0.56)	28.2(1.11)
12	1/2	FTSM-GZ12-NPT8-	36.0(1.42)	22.8(0.90)	22.0(0.87)	20.6(0.81)	9.5(0.37)	19.1(0.75)	33.0(1.30)
16	1/2	FTSM-GZ16-NPT8-	38.0(1.50)	24.4(0.96)	25.0(0.98)	23.8(0.94)	11.9(0.47)	19.1(0.75)	35.0(1.38)

## Тройник ввертный с наружной резьбой и монтажной гайкой

Прямая резьба SAE/MS

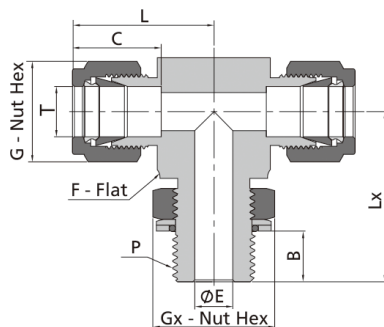

1. Размер E наименьший номинальный размер
2. SAE J1926-1, ISO 11926-1 и MS 16142.

### Метрическая трубка

### Прямая резьба SAE/MS

Т-трубка (in.)	P-SAE Резьба	P-SAE/MS Специфик	Артикул	Dimensions, in. (mm)							
				L	B	C	E	G	F	Lx	Gx
1/4	4	7/16-20	FTMN-YZ4-ST7-	1.12(28.5)	0.39(9.9)	0.60(15.2)	0.19(4.8)	0.56(14.3)	0.50(12.7)	1.06(27.0)	0.56(14.3)
3/8	6	9/16-18	FTMN-YZ6-ST9-	1.26(32.0)	0.44(11.2)	0.66(16.8)	0.28(7.1)	0.69(17.5)	0.63(15.9)	1.27(32.3)	0.69(17.5)
1/2	8	3/4-16	FTMN-YZ8-ST12-	1.48(37.6)	0.50(12.7)	0.90(22.9)	0.41(10.4)	0.87(22.2)	0.81(20.6)	1.49(37.8)	0.87(22.2)
3/4	12	11/16-12	FTMN-YZ12-ST17-	1.63(41.4)	0.66(16.8)	0.96(24.4)	0.62(15.7)	1.13(28.6)	1.06(27.0)	1.92(48.8)	1.25(31.8)
1	16	15/16-12	FTMN-YZ16-ST21-	1.99(50.5)	0.66(16.8)	1.23(31.2)	0.88(22.4)	1.50(38.1)	1.37(34.9)	2.11(53.6)	1.50(38.1)
1 1/4	20	15/8-12	FTMN-YZ20-ST26-	2.67(67.8)	0.66(16.8)	1.62(41.1)	1.09(27.7)	1.87(47.6)	1.69(42.9)	2.29(58.2)	1.87(47.6)
1 1/2	24	17/8-12	FTMN-YZ24-ST30-	3.07(78.0)	0.66(16.8)	1.97(50.0)	1.34(34.0)	2.25(57.2)	2.00(50.8)	2.38(60.5)	2.13(54.0)

## Тройник ввертный с наружной резьбой и монтажной гайкой

Цилиндрическая резьба ISO

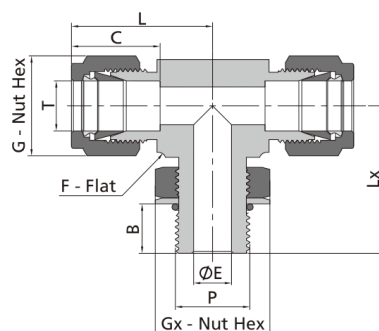

Размер E наименьший номинальный размер.

### Дюймовая трубка

### Цилиндрическая резьба ISO (PR)

Т-трубка (in.)	P-ISO Резьба	Артикул	Dimensions, in. (mm)							
			L	B	C	E	G	F	Lx	Gx
1/4	1/8	FTMN-YZ4-PR2-	1.06(26.9)	0.26(6.6)	0.60(15.2)	0.16(4.1)	0.56(14.3)	0.50(12.7)	1.04(26.4)	0.56(14.3)
1/4	1/4	FTMN-YZ4-PR4-	1.14(29.0)	0.35(9.0)	0.60(15.2)	0.19(4.8)	0.56(14.3)	0.63(15.9)	1.27(32.3)	0.75(19.1)
3/8	1/4	FTMN-YZ6-PR4-	1.20(30.5)	0.35(9.0)	0.66(16.8)	0.23(5.8)	0.69(17.5)	0.63(15.9)	1.27(32.3)	0.75(19.1)
1/2	3/8	FTMN-YZ8-PR6-	1.42(36.1)	0.37(9.4)	0.90(22.9)	0.31(7.9)	0.87(22.2)	0.81(20.6)	1.46(37.1)	0.87(22.2)
1/2	1/2	FTMN-YZ8-PR8-	1.50(38.1)	0.51(13.0)	0.90(22.9)	0.41(10.4)	0.87(22.2)	0.94(23.8)	1.71(43.4)	1.06(27.0)
5/8	1/2	FTMN-YZ10-PR8-	1.50(38.1)	0.51(13.0)	0.96(24.4)	0.47(11.9)	1.00(25.4)	0.94(23.8)	1.71(43.4)	1.06(27.0)
3/4	1/2	FTMN-YZ12-PR8-	1.57(39.9)	0.51(13.0)	0.96(24.4)	0.47(11.9)	1.13(28.6)	1.06(27.0)	1.78(45.2)	1.06(27.0)
3/4	3/4	FTMN-YZ12-PR12-	1.57(39.9)	0.51(13.0)	0.96(24.4)	0.62(15.7)	1.13(28.6)	1.06(27.0)	1.92(48.8)	1.37(34.9)
1	1	FTMN-YZ16-PR16-	1.93(49.0)	0.52(13.2)	1.23(31.2)	0.78(19.8)	1.50(38.1)	1.37(34.9)	2.11(53.6)	1.63(41.3)

### Метрическая резьба

### Цилиндрическая резьба ISO (PR)

Т-трубка (in.)	P-ISO Резьба	Артикул	Dimensions, in. (mm)							
			L	B	C	E	G	F	Lx	Gx
6	1/8	FTMN-GZ6-PR2-	27.0(1.06)	6.6(0.26)	15.3(0.60)	4.0(0.16)	14.0(0.55)	12.7(0.50)	26.4(1.04)	14.3(0.56)
6	1/4	FTMN-GZ6-PR4-	29.0(1.14)	9.0(0.35)	15.3(0.60)	4.8(0.19)	14.0(0.55)	15.9(0.63)	32.2(1.27)	19.1(0.75)
8	1/8	FTMN-GZ8-PR2-	28.8(1.13)	6.6(0.26)	16.2(0.64)	4.0(0.16)	16.0(0.63)	14.3(0.56)	27.5(1.08)	14.3(0.56)
8	1/4	FTMN-GZ8-PR4-	29.9(1.18)	9.0(0.35)	16.2(0.64)	5.9(0.23)	16.0(0.63)	15.9(0.63)	32.2(1.27)	19.1(0.75)
10	1/4	FTMN-GZ10-PR4-	33.5(1.32)	9.0(0.35)	17.2(0.68)	5.9(0.23)	19.0(0.75)	20.6(0.81)	35.1(1.38)	19.1(0.75)
12	3/8	FTMN-GZ12-PR6-	36.0(1.42)	9.4(0.37)	22.8(0.90)	7.9(0.31)	22.0(0.87)	20.6(0.81)	37.1(1.46)	22.2(0.87)
12	1/2	FTMN-GZ12-PR8-	38.0(1.50)	13.0(0.51)	22.8(0.90)	9.5(0.37)	22.0(0.87)	23.8(0.94)	43.5(1.71)	27.0(1.06)

# Размеры

## Тройник с боковым отводом с наружной резьбой с монтажной гайкой

Прямая резьба SAE/MS

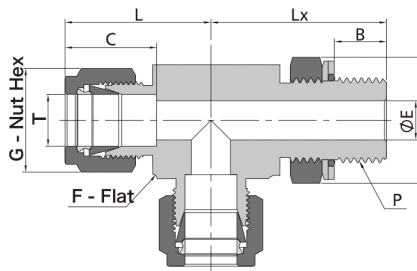

1. Размер E наименьший номинальный размер.
2. SAE J1926-1, ISO 11926-1 и MS 16142.

### Дюймовая трубка

### Прямая резьба SAE/MS

Т-Трубка (in.)	P-SAE Размер	P-SAE/MS Специфик резьбы	Артикул	Размеры, дюймы (мм)							
				L	B	C	E	G	F	Lx	Gx
1/4	4	7/16-20	FTSMN-YZ4-ST7-	1.12(28.5)	0.39(9.9)	0.60(15.2)	0.19(4.8)	0.56(14.3)	0.50(12.7)	1.06(27.0)	0.56(14.3)
3/8	6	9/16-18	FTSMN-YZ6-ST9-	1.26(32.0)	0.44(11.2)	0.66(16.8)	0.28(7.1)	0.69(17.5)	0.63(15.9)	1.27(32.3)	0.69(17.5)
1/2	8	3/4-16	FTSMN-YZ8-ST12-	1.48(37.6)	0.50(12.7)	0.90(22.9)	0.41(10.4)	0.87(22.2)	0.81(20.6)	1.49(37.8)	0.87(22.2)
3/4	12	1 1/16-12	FTSMN-YZ12-ST17-	1.63(41.4)	0.66(16.8)	0.96(24.4)	0.62(15.7)	1.25(31.75)	1.06(27.0)	1.92(48.8)	1.25(31.8)
1	16	1 5/16-12	FTSMN-YZ16-ST21-	1.99(50.5)	0.66(16.8)	1.23(31.2)	0.88(22.4)	1.50(38.1)	1.37(34.9)	2.11(53.6)	1.50(38.1)
1 1/4	20	1 5/8-12	FTSMN-YZ20-ST26-	2.67(67.8)	0.66(16.8)	1.62(41.1)	1.09(27.7)	1.87(47.6)	1.69(42.9)	2.29(58.2)	1.87(47.6)
1 1/2	24	1 7/8-12	FTSMN-YZ24-ST30-	3.07(78.0)	0.66(16.8)	1.97(50.0)	1.34(34.0)	2.25(57.2)	2.00(50.8)	2.38(60.5)	2.13(54.0)

## Тройник с боковым отводом с наружной резьбой с монтажной гайкой

Цилиндрическая резьба ISO

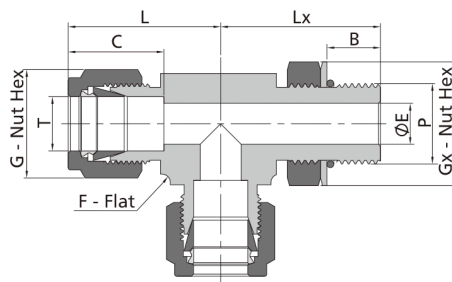

Размер E наименьший номинальный размер.

### Дюймовая трубка

### Цилиндрическая резьба ISO (PR)

Т-Трубка (in.)	P-ISO Размер	Артикул	Размеры, дюймы. (мм)							
			L	B	C	E	G	F	Lx	Gx
1/4	1/8	FTSMN-YZ4-PR2-	1.06(26.9)	0.26(6.6)	0.60(15.2)	0.16(4.1)	0.56(14.3)	0.50(12.7)	1.04(26.4)	0.56(14.3)
1/4	1/4	FTSMN-YZ4-PR4-	1.14(29.0)	0.35(9.0)	0.60(15.2)	0.19(4.8)	0.56(14.3)	0.63(15.9)	1.27(32.3)	0.75(19.1)
3/8	1/4	FTSMN-YZ6-PR4-	1.20(30.5)	0.35(9.0)	0.66(16.8)	0.23(5.8)	0.69(17.5)	0.63(15.9)	1.27(32.3)	0.75(19.1)
1/2	3/8	FTSMN-YZ8-PR6-	1.42(36.1)	0.37(9.4)	0.90(22.9)	0.31(7.9)	0.87(22.2)	0.81(20.6)	1.46(37.1)	0.87(22.2)
1/2	1/2	FTSMN-YZ8-PR8-	1.50(38.1)	0.51(13.0)	0.90(22.9)	0.41(10.4)	0.87(22.2)	0.94(23.8)	1.71(43.4)	1.06(27.0)
5/8	1/2	FTSMN-YZ10-PR8-	1.50(38.1)	0.51(13.0)	0.96(24.4)	0.47(11.9)	1.00(25.4)	0.94(23.8)	1.71(43.4)	1.06(27.0)
3/4	1/2	FTSMN-YZ12-PR8-	1.57(39.9)	0.51(13.0)	0.96(24.4)	0.47(11.9)	1.13(28.6)	1.06(27.0)	1.78(45.2)	1.06(27.0)
3/4	3/4	FTSMN-YZ12-PR12-	1.57(39.9)	0.51(13.0)	0.96(24.4)	0.62(15.7)	1.13(28.6)	1.06(27.0)	1.92(48.8)	1.37(34.9)
1	1	FTSMN-YZ16-PR16-	1.93(49.0)	0.52(13.2)	1.23(31.2)	0.78(19.8)	1.50(38.1)	1.37(34.9)	2.11(53.6)	1.63(41.3)

### Метрическая трубка

### Цилиндрическая резьба ISO (PR)

Т-Трубка (мм.)	P-ISO Размер	Артикул	Размеры, дюймы. (мм)							
			L	B	C	E	G	F	Lx	Gx
6	1/8	FTSMN-GZ6-PR2-	27.0(1.06)	6.6(0.26)	15.3(0.60)	4.0(0.16)	14.0(0.55)	12.7(0.50)	26.4(1.04)	14.3(0.56)
6	1/4	FTSMN-GZ6-PR4-	29.0(1.14)	9.0(0.35)	15.3(0.60)	4.8(0.19)	14.0(0.55)	15.9(0.63)	32.2(1.27)	19.1(0.75)
8	1/8	FTSMN-GZ8-PR2-	28.8(1.13)	6.6(0.26)	16.2(0.64)	4.0(0.16)	16.0(0.63)	14.3(0.56)	27.5(1.08)	14.3(0.56)
8	1/4	FTSMN-GZ8-PR4-	29.9(1.18)	9.0(0.35)	16.2(0.64)	5.9(0.23)	16.0(0.63)	15.9(0.63)	32.2(1.27)	19.1(0.75)
10	1/4	FTSMN-GZ10-PR4-	33.5(1.32)	9.0(0.35)	17.2(0.68)	5.9(0.23)	19.0(0.75)	20.6(0.81)	35.1(1.38)	19.1(0.75)
12	3/8	FTSMN-GZ12-PR6-	36.0(1.42)	9.4(0.37)	22.8(0.90)	7.9(0.31)	22.0(0.87)	20.6(0.81)	37.1(1.46)	22.2(0.87)
12	1/2	FTSMN-GZ12-PR8-	38.0(1.50)	13.0(0.51)	22.8(0.90)	9.5(0.37)	22.0(0.87)	23.8(0.94)	43.5(1.71)	27.0(1.06)

## Тройник ввертный с внутренней резьбой

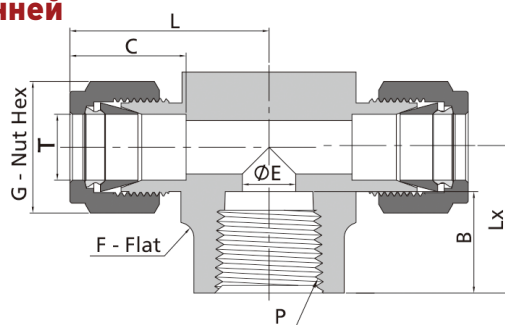

Дюймовая трубка			Резьба NPT						
Т-Трубка. (in.)	Р-NPT Резьба	Артикул	Размеры, дюймы. (мм)						
			L	C	G	F	E	B	Lx
1/8	1/8	FTW-YZ2-NPT2-	0.97(24.6)	0.50(12.7)	0.44(11.1)	0.50(12.7)	0.09(2.3)	0.41(10.4)	0.75(19.1)
3/16	1/8	FTW-YZ3-NPT2-	1.01(25.7)	0.54(13.7)	0.50(12.7)	0.50(12.7)	0.12(3.0)	0.41(10.4)	0.75(19.1)
1/4	1/8	FTW-YZ4-NPT2-	1.06(26.9)	0.60(15.2)	0.56(14.3)	0.50(12.7)	0.19(4.8)	0.41(10.4)	0.75(19.1)
1/4	1/4	FTW-YZ4-NPT4-	1.17(29.7)	0.60(15.2)	0.56(14.3)	0.69(17.5)	0.19(4.8)	0.59(15.0)	0.88(22.4)
5/16	1/8	FTW-YZ5-NPT2-	1.17(29.7)	0.64(16.2)	0.63(15.9)	0.63(15.9)	0.25(6.4)	0.41(10.4)	0.75(19.1)
3/8	1/4	FTW-YZ6-NPT4-	1.23(31.2)	0.66(16.8)	0.69(17.5)	0.69(17.5)	0.28(7.1)	0.59(15.0)	0.88(22.4)
3/8	3/8	FTW-YZ6-NPT6-	1.31(33.3)	0.66(16.8)	0.69(17.5)	0.81(20.6)	0.28(7.1)	0.59(15.0)	0.88(22.4)
3/8	1/2	FTW-YZ6-NPT8-	1.42(36.1)	0.66(16.8)	0.69(17.5)	1.00(25.4)	0.28(7.1)	0.78(19.8)	1.12(28.4)
1/2	1/4	FTW-YZ8-NPT4-	1.42(36.1)	0.90(22.9)	0.87(22.2)	0.81(20.6)	0.41(10.4)	0.59(15.0)	0.88(22.4)
1/2	3/8	FTW-YZ8-NPT6-	1.42(36.1)	0.90(22.9)	0.87(22.2)	0.81(20.6)	0.41(10.4)	0.59(15.0)	0.88(22.4)
1/2	1/2	FTW-YZ8-NPT8-	1.53(38.9)	0.90(22.9)	0.87(22.2)	1.00(25.4)	0.41(10.4)	0.78(19.8)	1.12(28.4)
5/8	1/2	FTW-YZ10-NPT8-	1.53(38.9)	0.96(24.4)	1.00(25.4)	1.00(25.4)	0.50(12.7)	0.78(19.8)	1.12(28.4)
3/4	3/4	FTW-YZ12-NPT12-	1.76(44.7)	0.96(24.4)	1.13(28.6)	1.37(34.9)	0.62(15.7)	0.81(20.6)	1.25(31.8)
7/8	3/4	FTW-YZ14-NPT12-	1.76(44.7)	1.02(25.9)	1.25(31.8)	1.37(34.9)	0.72(18.3)	0.81(20.6)	1.25(31.8)
1	3/4	FTW-YZ16-NPT12-	1.93(49.0)	1.23(31.2)	1.50(38.1)	1.37(34.9)	0.88(22.4)	0.81(20.6)	1.25(31.8)
1	1	FTW-YZ16-NPT16-	2.11(53.6)	1.23(31.2)	1.50(38.1)	1.69(42.9)	0.88(22.4)	1.00(25.4)	1.50(38.1)

Метрическая резьба			Резьба NPT						
Т-Трубка. (мм.)	Р-NPT Резьба	Артикул	Размеры, дюймы. (мм)						
			L	C	G	F	E	B	Lx
6	1/8	FTW-GZ6-NPT2-	27.0(1.06)	15.3(0.60)	14.0(0.55)	12.7(0.50)	4.8(0.19)	10.4(0.41)	19.0(0.75)
6	1/4	FTW-GZ6-NPT4-	29.8(1.17)	15.3(0.60)	14.0(0.55)	17.5(0.69)	4.8(0.19)	15.0(0.59)	22.4(0.88)
8	1/8	FTW-GZ8-NPT2-	29.9(1.18)	16.2(0.64)	16.0(0.63)	15.9(0.63)	6.4(0.25)	10.4(0.41)	19.0(0.75)
8	1/4	FTW-GZ8-NPT4-	30.6(1.2)	16.2(0.64)	16.0(0.63)	17.5(0.69)	6.4(0.25)	15.0(0.59)	22.4(0.88)
10	1/4	FTW-GZ10-NPT4-	33.5(1.32)	17.2(0.68)	19.0(0.75)	20.6(0.81)	7.9(0.31)	15.0(0.59)	22.4(0.88)
12	1/8	FTW-GZ12-NPT2-	36.0(1.42)	22.8(0.90)	22.0(0.87)	20.6(0.81)	6.4(0.25)	10.4(0.41)	22.3(0.88)
12	1/4	FTW-GZ12-NPT4-	36.0(1.42)	22.8(0.90)	22.0(0.87)	20.6(0.81)	9.5(0.37)	15.0(0.59)	22.4(0.88)
12	3/8	FTW-GZ12-NPT6-	36.0(1.42)	22.8(0.90)	22.0(0.87)	20.6(0.81)	9.5(0.37)	15.0(0.59)	22.4(0.88)
12	1/2	FTW-GZ12-NPT8-	38.8(1.53)	22.8(0.90)	22.0(0.87)	25.4(1.00)	9.5(0.37)	19.8(0.78)	28.5(1.12)
16	1/2	FTW-GZ16-NPT8-	38.8(1.53)	24.4(0.96)	25.0(0.98)	25.4(1.00)	12.7(0.50)	19.8(0.78)	28.4(1.12)

## Тройник с боковым отводом с внутренней резьбой

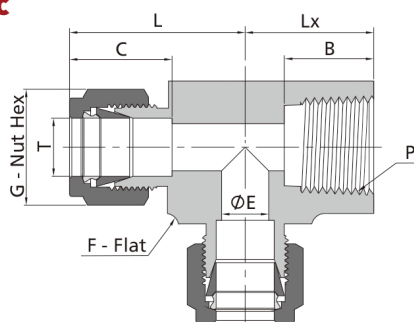

Дюймовая трубка			Резьба NPT						
Т-Трубка. (дюйм.)	Р-NPT Резьба	Артикул	Размеры, дюймы. (мм)						
			L	C	G	F	E	B	Lx
1/8	1/8	FTSW-YZ2-NPT2-	0.97(24.6)	0.50(12.7)	0.44(11.1)	0.50(12.7)	0.09(2.3)	0.41(10.4)	0.75(19.1)
3/16	1/8	FTSW-YZ3-NPT2-	1.01(25.7)	0.54(13.7)	0.50(12.7)	0.50(12.7)	0.12(3.0)	0.41(10.4)	0.75(19.1)
1/4	1/8	FTSW-YZ4-NPT2-	1.06(26.9)	0.60(15.2)	0.56(14.3)	0.50(12.7)	0.19(4.8)	0.41(10.4)	0.75(19.1)
1/4	1/4	FTSW-YZ4-NPT4 -	1.17(29.7)	0.60(15.2)	0.56(14.3)	0.69(17.5)	0.19(4.8)	0.59(15.0)	0.88(22.4)
5/16	1/8	FTSW-YZ5-NPT2-	1.17(29.7)	0.64(16.2)	0.63(15.9)	0.63(15.9)	0.25(6.4)	0.41(10.4)	0.75(19.1)
3/8	1/4	FTSW-YZ6-NPT4 -	1.23(31.2)	0.66(16.8)	0.69(17.5)	0.69(17.5)	0.28(7.1)	0.59(15.0)	0.88(22.4)
1/2	1/4	FTSW-YZ8-NPT4 -	1.42(36.1)	0.90(22.9)	0.87(22.2)	0.81(20.6)	0.41(10.4)	0.59(15.0)	0.88(22.4)
1/2	3/8	FTSW-YZ8-NPT6-	1.42(36.1)	0.90(22.9)	0.87(22.2)	0.81(20.6)	0.41(10.4)	0.59(15.0)	0.88(22.4)
1/2	1/2	FTSW-YZ8-NPT8-	1.57(39.9)	0.90(22.9)	0.87(22.2)	1.06(27.0)	0.41(10.4)	0.78(19.8)	1.12(28.4)
5/8	1/2	FTSW-YZ10-NPT8-	1.57(39.9)	0.96(24.4)	1.00(25.4)	1.06(27.0)	0.50(12.7)	0.78(19.8)	1.12(28.4)
3/4	3/4	FTSW-YZ12-NPT12-	1.76(44.7)	0.96(24.4)	1.13(28.6)	1.37(34.9)	0.62(15.7)	0.81(20.6)	1.25(31.8)
7/8	1/2	FTSW-YZ14-NPT8-	1.76(44.7)	1.02(25.9)	1.25(31.8)	1.37(34.9)	0.62(15.7)	0.78(19.8)	1.12(28.4)
7/8	3/4	FTSW-YZ14-NPT12-	1.76(44.7)	1.02(25.9)	1.25(31.8)	1.37(34.9)	0.72(18.3)	0.81(20.6)	1.25(31.8)
1	3/4	FTSW-YZ16-NPT12-	1.93(49.0)	1.23(31.2)	1.50(38.1)	1.37(34.9)	0.88(22.4)	0.81(20.6)	1.25(31.8)
1	1	FTSW-YZ16-NPT16-	2.11(53.6)	1.23(31.2)	1.50(38.1)	1.69(42.9)	0.88(22.4)	1.00(25.4)	1.50(38.1)

Метрическая трубка			Резьба NPT						
Т-Трубка. (мм.)	Р-NPT Резьба	Артикул	Размеры, дюймы. (мм)						
			L	C	G	F	E	B	Lx
6	1/8	FTSW-GZ6-NPT2-	27.0(1.06)	15.3(0.60)	14.0(0.55)	12.7(0.50)	4.8(0.19)	10.4(0.41)	19.0(0.75)
6	1/4	FTSW-GZ6-NPT4-	29.8(1.17)	15.3(0.60)	14.0(0.55)	17.5(0.69)	4.8(0.19)	15.0(0.59)	22.4(0.88)
8	1/8	FTSW-GZ8-NPT2-	29.9(1.18)	16.2(0.64)	16.0(0.63)	15.9(0.63)	6.4(0.25)	10.4(0.41)	19.0(0.75)
8	1/4	FTSW-GZ8-NPT4 -	30.6(1.20)	16.2(0.64)	16.0(0.63)	17.5(0.69)	6.4(0.25)	15.0(0.59)	22.4(0.88)
10	1/4	FTSW-GZ10-NPT4-	33.5(1.32)	17.2(0.68)	19.0(0.75)	20.6(0.81)	7.9(0.31)	15.0(0.59)	22.4(0.88)
12	1/4	FTSW-GZ12-NPT4-	36.0(1.42)	22.8(0.90)	22.0(0.87)	20.6(0.81)	9.5(0.37)	15.0(0.59)	22.4(0.88)
12	3/8	FTSW-GZ12-NPT6-	36.0(1.42)	22.8(0.90)	22.0(0.87)	20.6(0.81)	9.5(0.37)	15.0(0.59)	23.1(0.91)
12	1/2	FTSW-GZ12-NPT8-	38.8(1.53)	22.8(0.90)	22.0(0.87)	25.4(1.00)	9.5(0.37)	19.8(0.78)	28.5(1.12)
16	1/2	FTSW-GZ 16-NPT8-	39.8(1.57)	24.4(0.96)	25.0(0.98)	27.0(1.06)	12.7(0.50)	19.8(0.78)	28.4(1.12)



## Тройник проходной

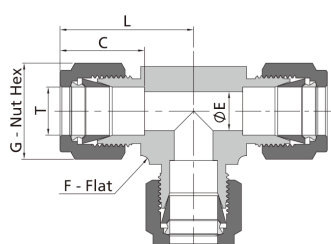

## Дюймовая трубка

Т-Трубка (in.)	Артикул	Размеры, дюйм. (мм)				
		L	C	G	F	E
1/16	FTP-YZ1-	0.70(17.8)	0.34(8.6)	0.31(7.9)	0.37(9.5)	0.05(1.3)
1/8	FTP-YZ2-	0.87(22.2)	0.50(12.7)	0.44(11.1)	0.37(9.5)	0.09(2.3)
3/16	FTP-YZ3-	0.96(24.4)	0.54(13.7)	0.50(12.7)	0.44(11.1)	0.12(3.0)
1/4	FTP-YZ4-	1.06(26.9)	0.60(15.2)	0.56(14.3)	0.50(12.7)	0.19(4.8)
5/16	FTP-YZ5-	1.17(29.7)	0.64(16.2)	0.63(15.9)	0.63(15.9)	0.25(6.4)
3/8	FTP-YZ6-	1.20(30.5)	0.66(16.8)	0.69(17.5)	0.63(15.9)	0.28(7.1)
1/2	FTP-YZ8-	1.42(36.1)	0.90(22.9)	0.87(22.2)	0.81(20.6)	0.41(10.4)
5/8	FTP-YZ10-	1.53(38.9)	0.96(24.4)	1.00(25.4)	1.00(25.4)	0.50(12.7)
3/4	FTP-YZ12-	1.57(39.9)	0.96(24.4)	1.13(28.6)	1.06(27.0)	0.62(15.7)
7/8	FTP-YZ14-	1.76(44.7)	1.02(25.9)	1.25(31.8)	1.37(34.9)	0.72(18.3)
1	FTP-YZ16-	1.93(49.0)	1.23(31.2)	1.50(38.1)	1.37(34.9)	0.88(22.4)
1 1/8	FTP-YZ18-	2.63(66.9)	1.44(36.7)	1.75(44.5)	1.69(42.9)	0.97(24.6)
1 1/4	FTP-YZ20-	2.62(66.5)	1.62(41.1)	1.87(47.6)	1.69(42.9)	1.09(27.7)
1 1/2	FTP-YZ24-	3.07(78.0)	1.97(50.0)	2.25(57.2)	2.00(50.8)	1.34(34.0)

## Metric Tube

Т-Трубка (мм.)	Артикул	Размеры, дюйм. (мм)				
		L	C	G	F	E
2	FTP-GZ2-	22.3(0.88)	12.9(0.51)	12.0(0.47)	9.5(0.37)	1.7(0.07)
3	FTP-GZ3-	22.3(0.88)	12.9(0.51)	12.0(0.47)	9.5(0.37)	2.4(0.09)
4	FTP-GZ4-	25.4(1.00)	13.7(0.54)	12.0(0.47)	12.7(0.50)	2.4(0.09)
6	FTP-GZ6-	27.0(1.06)	15.3(0.60)	14.0(0.55)	12.7(0.50)	4.8(0.19)
8	FTP-GZ8-	29.9(1.18)	16.2(0.64)	16.0(0.63)	15.9(0.63)	6.4(0.25)
10	FTP-GZ10-	31.5(1.24)	17.2(0.68)	19.0(0.75)	17.5(0.69)	7.9(0.31)
12	FTP-GZ12-	36.0(1.42)	22.8(0.90)	22.0(0.87)	20.6(0.81)	9.5(0.37)
14	FTP-GZ14-	38.8(1.53)	24.4(0.96)	25.0(0.98)	25.4(1.00)	11.1(0.44)
15	FTP-GZ15-	38.8(1.53)	24.4(0.96)	25.0(0.98)	25.4(1.00)	11.9(0.47)
16	FTP-GZ16-	38.8(1.53)	24.4(0.96)	25.0(0.98)	25.4(1.00)	12.7(0.50)
18	FTP-GZ18-	39.8(1.57)	24.4(0.96)	30.0(1.18)	27.0(1.06)	15.1(0.59)
20	FTP-GZ20-	44.6(1.76)	26.0(1.02)	32.0(1.26)	34.9(1.37)	15.9(0.63)
22	FTP-GZ22-	44.6(1.76)	26.0(1.02)	32.0(1.26)	34.9(1.37)	18.3(0.72)
25	FTP-GZ25-	49.1(1.93)	31.3(1.23)	38.0(1.50)	34.9(1.37)	21.8(0.86)
28	FTP-GZ28-	64.0(2.52)	36.6(1.44)	46.0(1.81)	42.9(1.69)	21.8(0.86)
30	FTP-GZ30-	69.9(2.75)	39.6(1.56)	50.0(1.97)	42.9(1.69)	26.2(1.03)
32	FTP-GZ32-	72.3(2.85)	42.0(1.65)	50.0(1.97)	42.9(1.69)	28.6(1.13)
38	FTP-GZ38-	84.0(3.31)	49.4(1.94)	60.0(2.36)	50.8(2.00)	33.7(1.33)

# Размеры

## Тройник переходной

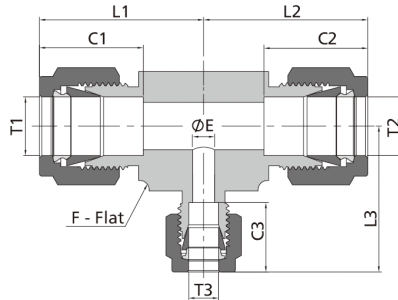

### Дюймовая трубка

T1- Трубка. (in.)	T2- Трубка. (in.)	T3- Трубка. (in.)	Артикул	Размеры, дюйм. (мм)							
				L1	L2	L3	C1	C2	C3	F	E
1/4	1/4	1/8	FTR-YZ4-YZ4-YZ2-	1.05(26.7)	1.05(26.7)	0.96(24.4)	0.60(15.2)	0.60(15.2)	0.50(12.7)	0.50(12.7)	0.09(2.3)
3/8	1/4	1/4	FTR-YZ6-YZ4-YZ4-	1.20(30.5)	1.14(29.0)	1.14(29.0)	0.66(16.8)	0.60(15.2)	0.60(15.2)	0.63(15.9)	0.19(4.8)
3/8	1/4	3/8	FTR-YZ6-YZ4-YZ6-	1.20(30.5)	1.14(29.0)	1.20(30.5)	0.66(16.8)	0.60(15.2)	0.66(16.8)	0.63(15.9)	0.19(4.8)
3/8	3/8	1/4	FTR-YZ6-YZ6-YZ4-	1.20(30.5)	1.20(30.5)	1.14(29.0)	0.66(16.8)	0.66(16.8)	0.60(15.2)	0.63(15.9)	0.19(4.8)
1/2	1/4	1/4	FTR-YZ8-YZ4-YZ4-	1.42(36.1)	1.22(30.9)	1.22(30.9)	0.90(22.9)	0.60(15.2)	0.60(15.2)	0.81(20.6)	0.19(4.8)
1/2	1/4	1/2	FTR-YZ8-YZ4-YZ8-	1.42(36.1)	1.25(31.8)	1.42(36.1)	0.90(22.9)	0.60(15.2)	0.90(22.9)	0.81(20.6)	0.19(4.8)
1/2	3/8	3/8	FTR-YZ8-YZ6-YZ6-	1.42(36.1)	1.31(33.3)	1.31(33.3)	0.90(22.9)	0.66(16.8)	0.66(16.8)	0.81(20.6)	0.28(7.1)
1/2	3/8	1/2	FTR-YZ8-YZ6-YZ8-	1.42(36.1)	1.31(33.3)	1.42(36.1)	0.90(22.9)	0.66(16.8)	0.90(22.9)	0.81(20.6)	0.28(7.1)
1/2	1/2	1/4	FTR-YZ8-YZ8-YZ4-	1.42(36.1)	1.42(36.1)	1.25(31.8)	0.90(22.9)	0.90(22.9)	0.60(15.2)	0.81(20.6)	0.19(4.8)
1/2	1/2	3/8	FTR-YZ8-YZ8-YZ6-	1.42(36.1)	1.42(36.1)	1.31(33.3)	0.90(22.9)	0.90(22.9)	0.66(16.8)	0.81(20.6)	0.28(7.1)
5/8	3/8	3/8	FTR-YZ10-YZ6-YZ6-	1.53(38.9)	1.42(36.1)	1.42(36.1)	0.96(24.4)	0.66(16.8)	0.66(16.8)	1.00(25.4)	0.28(7.1)
5/8	3/8	1/2	FTR-YZ10-YZ6-YZ8-	1.53(38.9)	1.42(36.1)	1.53(38.9)	0.96(24.4)	0.66(16.8)	0.90(22.9)	1.00(25.4)	0.28(7.1)
5/8	1/2	3/8	FTR-YZ10-YZ8-YZ6-	1.53(38.9)	1.53(38.9)	1.42(36.1)	0.96(24.4)	0.90(22.9)	0.66(16.8)	1.00(25.4)	0.28(7.1)
5/8	1/2	1/2	FTR-YZ10-YZ8-YZ8-	1.53(38.9)	1.53(38.9)	1.53(38.9)	0.96(24.4)	0.90(22.9)	0.90(22.9)	1.00(25.4)	0.41(10.4)
5/8	5/8	3/8	FTR-YZ10-YZ10-YZ6-	1.53(38.9)	1.53(38.9)	1.42(36.1)	0.96(24.4)	0.96(24.4)	0.66(16.8)	1.00(25.4)	0.28(7.1)
5/8	5/8	1/2	FTR-YZ10-YZ10-YZ8-	1.53(38.9)	1.53(38.9)	1.53(38.9)	0.96(24.4)	0.96(24.4)	0.90(22.9)	1.00(25.4)	0.41(10.4)
3/4	3/8	3/8	FTR-YZ12-YZ6-YZ6-	1.56(39.6)	1.45(36.9)	1.45(36.9)	0.96(24.4)	0.66(16.8)	0.66(16.8)	1.06(27.0)	0.28(7.1)
3/4	1/2	3/8	FTR-YZ12-YZ8-YZ6-	1.56(39.6)	1.56(39.6)	1.45(36.9)	0.96(24.4)	0.90(22.9)	0.66(16.8)	1.06(27.0)	0.28(7.1)
3/4	1/2	1/2	FTR-YZ12-YZ8-YZ8-	1.56(39.6)	1.56(39.6)	1.56(39.6)	0.96(24.4)	0.90(22.9)	0.90(22.9)	1.06(27.0)	0.41(10.4)
3/4	5/8	3/8	FTR-YZ12-YZ10-YZ6-	1.56(39.6)	1.56(39.6)	1.45(36.9)	0.96(24.4)	0.96(24.4)	0.66(16.8)	1.06(27.0)	0.28(7.1)
3/4	5/8	1/2	FTR-YZ12-YZ10-YZ8-	1.56(39.6)	1.56(39.6)	1.56(39.6)	0.96(24.4)	0.96(24.4)	0.90(22.9)	1.06(27.0)	0.41(10.4)
3/4	5/8	5/8	FTR-YZ12-YZ10-YZ10-	1.56(39.6)	1.56(39.6)	1.56(39.6)	0.96(24.4)	0.96(24.4)	0.96(24.4)	1.06(27.0)	0.50(12.7)
3/4	3/4	1/4	FTR-YZ12-YZ12-YZ4-	1.56(39.6)	1.56(39.6)	1.43(36.3)	0.96(24.4)	0.96(24.4)	0.60(15.2)	1.06(27.0)	0.19(4.8)
3/4	3/4	3/8	FTR-YZ12-YZ12-YZ6-	1.56(39.6)	1.56(39.6)	1.45(36.9)	0.96(24.4)	0.96(24.4)	0.66(16.8)	1.06(27.0)	0.28(7.1)
3/4	3/4	1/2	FTR-YZ12-YZ12-YZ8-	1.56(39.6)	1.56(39.6)	1.56(39.6)	0.96(24.4)	0.96(24.4)	0.90(22.9)	1.06(27.0)	0.41(10.4)
3/4	3/4	5/8	FTR-YZ12-YZ12-YZ10-	1.56(39.6)	1.56(39.6)	1.56(39.6)	0.96(24.4)	0.96(24.4)	0.96(24.4)	1.06(27.0)	0.50(12.7)
7/8	1/2	3/4	FTR-YZ14-YZ8-YZ12-	1.76(44.7)	1.76(44.7)	1.76(44.7)	1.02(25.9)	0.90(22.9)	0.96(24.4)	1.37(34.9)	0.41(10.4)
7/8	5/8	3/8	FTR-YZ14-YZ10-YZ6-	1.76(44.7)	1.76(44.7)	1.65(41.9)	1.02(25.9)	0.96(24.4)	0.66(16.8)	1.37(34.9)	0.28(7.1)
7/8	3/4	3/8	FTR-YZ14-YZ12-YZ6-	1.76(44.7)	1.76(44.7)	1.65(41.9)	1.02(25.9)	0.96(24.4)	0.66(16.8)	1.37(34.9)	0.28(7.1)
7/8	3/4	1/2	FTR-YZ14-YZ12-YZ8-	1.76(44.7)	1.76(44.7)	1.76(44.7)	1.02(25.9)	0.96(24.4)	0.90(22.9)	1.37(34.9)	0.41(10.4)
7/8	3/4	3/4	FTR-YZ14-YZ12-YZ12-	1.76(44.7)	1.76(44.7)	1.76(44.7)	1.02(25.9)	0.96(24.4)	0.96(24.4)	1.37(34.9)	0.62(15.7)
7/8	7/8	1/4	FTR-YZ14-YZ14-YZ4-	1.76(44.7)	1.76(44.7)	1.59(40.4)	1.02(25.9)	1.02(25.9)	0.60(15.2)	1.37(34.9)	0.19(4.8)
7/8	7/8	3/8	FTR-YZ14-YZ14-YZ6-	1.76(44.7)	1.76(44.7)	1.65(41.9)	1.02(25.9)	1.02(25.9)	0.66(16.8)	1.37(34.9)	0.28(7.1)
1	3/8	3/8	FTR-YZ16-YZ6-YZ6-	1.94(49.3)	1.65(41.9)	1.65(41.9)	1.23(31.2)	0.66(16.8)	0.66(16.8)	1.37(34.9)	0.28(7.1)
1	1/2	1/4	FTR-YZ16-YZ8-YZ4-	1.94(49.3)	1.76(44.7)	1.59(40.4)	1.23(31.2)	0.90(22.9)	0.60(15.2)	1.37(34.9)	0.19(4.8)
1	1/2	3/8	FTR-YZ16-YZ8-YZ6-	1.94(49.3)	1.76(44.7)	1.65(41.9)	1.23(31.2)	0.90(22.9)	0.66(16.8)	1.37(34.9)	0.28(7.1)
1	1/2	1/2	FTR-YZ16-YZ8-YZ8-	1.94(49.3)	1.76(44.7)	1.76(44.7)	1.23(31.2)	0.90(22.9)	0.90(22.9)	1.37(34.9)	0.41(10.4)
1	1/2	1	FTR-YZ16-YZ8-YZ16-	1.94(49.3)	1.76(44.7)	1.94(49.3)	1.23(31.2)	0.90(22.9)	1.23(31.2)	1.37(34.9)	0.41(10.4)
1	5/8	3/8	FTR-YZ16-YZ10-YZ6-	1.94(49.3)	1.76(44.7)	1.65(41.9)	1.23(31.2)	0.96(24.4)	0.66(16.8)	1.37(34.9)	0.28(7.1)
1	3/4	3/8	FTR-YZ 16-YZ12-YZ6-	1.94(49.3)	1.76(44.7)	1.65(41.9)	1.23(31.2)	0.96(24.4)	0.66(16.8)	1.37(34.9)	0.28(7.1)
1	3/4	1/2	FTR-YZ16-YZ12-YZ8-	1.94(49.3)	1.76(44.7)	1.76(44.7)	1.23(31.2)	0.96(24.4)	0.90(22.9)	1.37(34.9)	0.41(10.4)
1	3/4	5/8	FTR-YZ16-YZ12-YZ10-	1.94(49.3)	1.76(44.7)	1.76(44.7)	1.23(31.2)	0.96(24.4)	0.96(24.4)	1.37(34.9)	0.50(12.7)
1	3/4	1	FTR-YZ16-YZ12-YZ16-	1.94(49.3)	1.76(44.7)	1.94(49.3)	1.23(31.2)	0.96(24.4)	1.23(31.2)	1.37(34.9)	0.62(15.7)
1	7/8	1/4	FTR-YZ16-YZ14-YZ4-	1.94(49.3)	1.76(44.7)	1.59(40.4)	1.23(31.2)	1.02(25.9)	0.60(15.2)	1.37(34.9)	0.19(4.8)
1	7/8	3/8	FTR-YZ16-YZ14-YZ6-	1.94(49.3)	1.76(44.7)	1.65(41.9)	1.23(31.2)	1.02(25.9)	0.66(16.8)	1.37(34.9)	0.28(7.1)
1	7/8	1/2	FTR-YZ16-YZ14-YZ8-	1.94(49.3)	1.76(44.7)	1.76(44.7)	1.23(31.2)	1.02(25.9)	0.90(22.9)	1.37(34.9)	0.41(10.4)
1	7/8	3/4	FTR-YZ16-YZ14-YZ12-	1.94(49.3)	1.76(44.7)	1.76(44.7)	1.23(31.2)	1.02(25.9)	0.96(24.4)	1.37(34.9)	0.62(15.7)
1	7/8	7/8	FTR-YZ16-YZ14-YZ14-	1.94(49.3)	1.76(44.7)	1.76(44.7)	1.23(31.2)	1.02(25.9)	1.02(25.9)	1.37(34.9)	0.72(18.3)
1	1	1/4	FTR-YZ16-YZ16-YZ4-	1.94(49.3)	1.94(49.3)	1.59(40.4)	1.23(31.2)	1.23(31.2)	0.60(15.2)	1.37(34.9)	0.19(4.8)
1	1	3/8	FTR-YZ16-YZ16-YZ6-	1.94(49.3)	1.94(49.3)	1.65(41.9)	1.23(31.2)	1.23(31.2)	0.66(16.8)	1.37(34.9)	0.28(7.1)
1	1	1/2	FTR-YZ16-YZ16-YZ8-	1.94(49.3)	1.94(49.3)	1.76(44.7)	1.23(31.2)	1.23(31.2)	0.90(22.9)	1.37(34.9)	0.41(10.4)
1	1	5/8	FTR-YZ16-YZ16-YZ10-	1.94(49.3)	1.94(49.3)	1.76(44.7)	1.23(31.2)	1.23(31.2)	0.96(24.4)	1.37(34.9)	0.50(12.7)
1	1	3/4	FTR-YZ16-YZ16-YZ12-	1.94(49.3)	1.94(49.3)	1.76(44.7)	1.23(31.2)	1.23(31.2)	0.96(24.4)	1.37(34.9)	0.62(15.7)
1	1	7/8	FTR-YZ16-YZ16-YZ 14-	1.94(49.3)	1.94(49.3)	1.76(44.7)	1.23(31.2)	1.23(31.2)	1.02(25.9)	1.37(34.9)	0.72(18.3)
1 1/4	1 1/4	1	FTR-YZ20-YZ20-YZ16-	2.67(67.8)	2.67(67.8)	2.17(55.1)	1.62(41.2)	1.62(41.2)	1.23(31.3)	1.69(42.9)	0.88(22.4)
1 1/2	1 1/2	1	FTR-YZ24-YZ24-YZ16-	3.10(78.7)	3.10(78.7)	2.36(60.0)	1.97(50.0)	1.97(50.0)	1.23(31.3)	2.00(50.8)	0.88(22.4)

## Тройник переходной

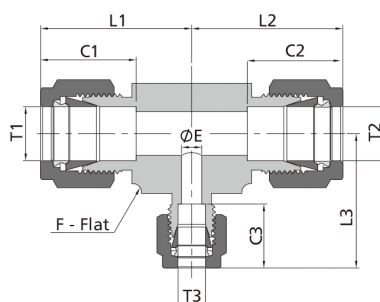

### Метрическая трубка

T1- Трубка. (in.)	T2- Трубка. (in.)	T3- Трубка. (in.)	Артикул	Размеры, дюйм. (мм)							
				L1	L2	L3	C1	C2	C3	F	E
3	3	6	FTR-GZ3-GZ3-GZ6-	24.7(0.97)	24.7(0.97)	27.0(1.06)	12.9(0.51)	12.9(0.51)	15.3(0.60)	12.7(0.50)	2.4(0.09)
6	6	3	FTR-GZ6-GZ6-GZ3-	27.0(1.06)	27.0(1.06)	24.7(0.97)	15.3(0.60)	15.3(0.60)	12.9(0.51)	12.7(0.50)	2.4(0.09)
6	6	8	FTR-GZ6-GZ6-GZ8-	28.0(1.10)	28.0(1.10)	28.8(1.13)	15.3(0.60)	15.3(0.60)	16.2(0.64)	14.3(0.56)	4.8(0.19)
8	8	6	FTR-GZ8-GZ8-GZ6-	30.0(1.18)	30.0(1.18)	29.0(1.14)	16.2(0.64)	16.2(0.64)	15.3(0.60)	15.9(0.63)	4.8(0.19)
8	8	12	FTR-GZ8-GZ8-GZ12-	35.2(1.39)	35.2(1.39)	36.0(1.42)	16.2(0.64)	16.2(0.64)	22.8(0.90)	20.6(0.81)	6.4(0.25)
10	10	6	FTR-GZ10-GZ10-GZ6-	31.5(1.24)	31.5(1.24)	29.9(1.18)	17.2(0.68)	17.2(0.68)	15.3(0.60)	17.5(0.69)	4.8(0.19)
10	10	8	FTR-GZ10-GZ10-GZ8-	31.5(1.24)	31.5(1.24)	30.7(1.21)	17.2(0.68)	17.2(0.68)	16.2(0.64)	17.5(0.69)	6.4(0.25)
12	12	6	FTR-GZ12-GZ12-GZ6-	36.0(1.42)	36.0(1.42)	31.8(1.25)	22.8(0.90)	22.8(0.90)	15.3(0.60)	20.6(0.81)	4.8(0.19)
12	12	8	FTR-GZ12-GZ12-GZ8-	36.0(1.42)	36.0(1.42)	32.0(1.26)	22.8(0.90)	22.8(0.90)	16.2(0.64)	20.6(0.81)	6.4(0.25)
12	12	14	FTR-GZ12-GZ12-GZ14-	38.0(1.50)	38.0(1.50)	38.0(1.50)	22.8(0.90)	22.8(0.90)	24.4(0.96)	25.4(1.00)	9.5(0.37)
12	12	18	FTR-GZ12-GZ12-GZ18-	39.8(1.57)	39.8(1.57)	39.8(1.57)	22.8(0.90)	22.8(0.90)	24.4(0.96)	27.0(1.06)	9.5(0.37)
14	14	8	FTR-GZ14-GZ14-GZ8-	38.0(1.50)	38.0(1.50)	35.5(1.40)	24.4(0.96)	24.4(0.96)	16.2(0.64)	25.4(1.00)	6.4(0.25)
14	14	10	FTR-GZ14-GZ14-GZ10-	38.0(1.50)	38.0(1.50)	36.7(1.44)	24.4(0.96)	24.4(0.96)	17.2(0.68)	25.4(1.00)	7.9(0.31)
15	15	12	FTR-GZ15-GZ15-GZ12-	38.8(1.53)	38.8(1.53)	38.8(1.53)	24.4(0.96)	24.4(0.96)	22.8(0.90)	25.4(1.00)	9.5(0.37)
16	8	16	FTR-GZ16-GZ8-GZ16-	38.8(1.53)	35.5(1.40)	38.8(1.53)	24.4(0.96)	16.2(0.64)	24.4(0.96)	25.4(1.00)	6.4(0.25)
16	16	12	FTR-GZ16-GZ16-GZ12-	38.8(1.53)	38.8(1.53)	38.9(1.53)	24.4(0.96)	24.4(0.96)	22.8(0.90)	25.4(1.00)	9.5(0.37)
18	18	8	FTR-GZ18-GZ18-GZ8-	39.8(1.57)	39.8(1.57)	39.0(1.54)	24.4(0.96)	24.4(0.96)	16.2(0.64)	27.0(1.06)	6.4(0.25)
18	18	10	FTR-GZ18-GZ18-GZ10-	39.8(1.57)	39.8(1.57)	37.4(1.47)	24.4(0.96)	24.4(0.96)	17.2(0.68)	27.0(1.06)	7.9(0.31)
18	18	12	FTR-GZ18-GZ18-GZ12-	39.8(1.57)	39.8(1.57)	39.8(1.57)	24.4(0.96)	24.4(0.96)	22.8(0.90)	27.0(1.06)	9.5(0.37)
18	18	14	FTR-GZ18-GZ18-GZ14-	39.8(1.57)	39.8(1.57)	39.8(1.57)	24.4(0.96)	24.4(0.96)	24.4(0.96)	27.0(1.06)	11.1(0.44)
20	20	14	FTR-GZ20-GZ20-GZ14-	44.6(1.76)	44.6(1.76)	44.6(1.76)	26.0(1.02)	26.0(1.02)	24.4(0.96)	34.9(1.37)	11.1(0.44)
22	22	12	FTR-GZ22-GZ22-GZ12-	44.6(1.76)	44.6(1.76)	44.6(1.76)	26.0(1.02)	26.0(1.02)	22.8(0.90)	34.9(1.37)	9.5(0.37)
25	25	12	FTR-GZ25-GZ25-GZ12-	49.1(1.93)	49.1(1.93)	44.7(1.76)	31.3(1.23)	31.3(1.23)	22.8(0.90)	34.9(1.37)	9.5(0.37)

## Крестовина проходная

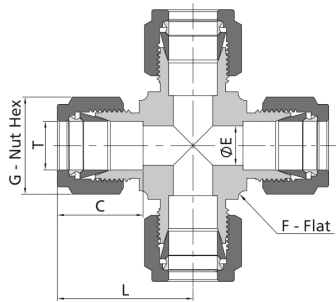

### Дюймовая трубка

Т-Трубка (дюйм.)	Артикул	Размеры, дюйм. (мм)				
		L	C	G	F	E
1/8	FKP-YZ2-	0.88(22.4)	0.50(12.7)	0.44(11.1)	0.37(9.5)	0.09(2.3)
3/16	FKP-YZ3-	0.96(24.4)	0.54(13.7)	0.50(12.7)	0.44(11.1)	0.12(3.0)
1/4	FKP-YZ4-	1.06(26.9)	0.60(15.2)	0.56(14.3)	0.50(12.7)	0.19(4.8)
5/16	FKP-YZ5-	1.17(29.7)	0.64(16.2)	0.63(15.9)	0.63(15.9)	0.25(6.4)
3/8	FKP-YZ6-	1.20(30.5)	0.66(16.8)	0.69(17.5)	0.63(15.9)	0.28(7.1)
1/2	FKP-YZ8-	1.42(36.1)	0.90(22.9)	0.87(22.2)	0.81(20.6)	0.41(10.4)
5/8	FKP-YZ10-	1.53(38.8)	0.96(24.4)	1.00(25.4)	1.0(25.4)	0.50(12.7)
3/4	FKP-YZ12-	1.57(39.9)	0.96(24.4)	1.13(28.6)	1.06(27.0)	0.62(15.7)
7/8	FKP-YZ14-	1.76(44.7)	1.02(25.9)	1.25(31.8)	1.37(34.9)	0.72(18.3)
1	FKP-YZ16-	1.93(49.0)	1.23(31.2)	1.50(38.1)	1.37(34.9)	0.88(22.4)

### Метрическая трубка

Т-Трубка (мм.)	Артикул	Размеры, дюйм. (мм)				
		L	C	G	F	E
3	FKP-GZ3-	22.3(0.88)	12.9(0.51)	12.0(0.47)	9.5(0.37)	2.4(0.09)
4	FKP-GZ4-	25.4(1.00)	13.7(0.54)	12.0(0.47)	12.7(0.50)	2.4(0.09)
6	FKP-GZ6-	27.0(1.06)	15.3(0.60)	14.0(0.55)	12.7(0.50)	4.8(0.19)
8	FKP-GZ8-	29.9(1.18)	16.2(0.64)	16.0(0.63)	15.9(0.63)	6.4(0.25)
10	FKP-GZ10-	33.5(1.32)	17.2(0.68)	19.0(0.75)	20.6(0.81)	7.9(0.31)
12	FKP-GZ12-	36.0(1.42)	22.8(0.90)	22.0(0.87)	20.6(0.81)	9.5(0.37)
16	FKP-GZ16-	37.0(1.46)	24.4(0.96)	25.0(0.98)	23.8(0.94)	12.7(0.50)
18	FKP-GZ18-	38.3(1.51)	24.4(0.96)	30.0(1.18)	27.0(1.06)	15.1(0.59)
20	FKP-GZ20-	44.6(1.76)	26.0(1.02)	32.0(1.26)	34.9(1.37)	15.9(0.63)
22	FKP-GZ22-	44.7(1.76)	26.0(1.02)	32.0(1.26)	34.9(1.37)	18.3(0.72)
25	FKP-GZ25-	49.2(1.94)	31.3(1.23)	38.0(1.50)	34.9(1.37)	21.8(0.86)

## Заглушка для трубки

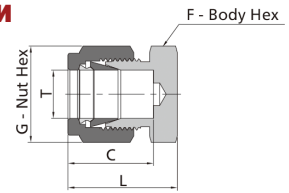

### Дюймовая трубка

Т-Трубка. (in.)	Артикул	Размеры, дюйм. (мм)			
		L	C	G	F
1/16	FD-YZ1-	0.59(15.0)	0.34(8.6)	0.31(7.9)	0.31(7.9)
1/8	FD-YZ2-	0.79(20.1)	0.50(12.7)	0.44(11.1)	0.44(11.1)
3/16	FD-YZ3-	0.84(21.3)	0.54(13.7)	0.50(12.7)	0.44(11.1)
1/4	FD-YZ4-	0.92(23.4)	0.60(15.2)	0.56(14.3)	0.50(12.7)
5/16	FD-YZ5-	0.96(24.4)	0.64(16.3)	0.63(15.9)	0.56(14.3)
3/8	FD-YZ6-	1.01(25.7)	0.66(16.8)	0.69(17.5)	0.63(15.9)
1/2	FD-YZ8-	1.15(29.2)	0.90(22.9)	0.87(22.2)	0.81(20.6)
5/8	FD-YZ10-	1.18(30.0)	0.96(24.4)	1.00(25.4)	0.94(23.8)
3/4	FD-YZ12-	1.24(31.5)	0.96(24.4)	1.13(28.6)	1.06(27.0)
7/8	FD-YZ14-	1.34(34.0)	1.02(25.9)	1.25(31.8)	1.19(30.2)
1	FD-YZ16-	1.51(38.4)	1.23(31.2)	1.50(38.1)	1.37(34.9)
1 1/8	FD-YZ18-	1.51(38.4)	1.44(36.7)	1.75(44.5)	1.63(41.3)
1 1/4	FD-YZ20-	2.10(53.3)	1.62(41.1)	1.87(47.6)	1.75(44.5)
1 1/2	FD-YZ24-	2.54(64.5)	1.97(50.0)	2.25(57.2)	2.13(54.0)

### Метрическая трубка

Т-Трубка. (мм.)	Артикул	Размеры, дюйм. (мм)			
		L	C	G	F
2	FD-GZ2-	20.1(0.79)	12.9(0.51)	12.0(0.47)	12.0(0.47)
3	FD-GZ3-	20.1(0.79)	12.9(0.51)	12.0(0.47)	12.0(0.47)
4	FD-GZ4-	21.3(0.84)	13.7(0.54)	12.0(0.47)	12.0(0.47)
6	FD-GZ6-	23.1(0.91)	15.3(0.60)	14.0(0.55)	14.0(0.55)
8	FD-GZ8-	24.5(0.96)	16.2(0.64)	16.0(0.63)	15.0(0.59)
10	FD-GZ10-	26.6(1.05)	17.2(0.68)	19.0(0.75)	18.0(0.71)
12	FD-GZ12-	29.1(1.15)	22.8(0.90)	22.0(0.87)	22.0(0.87)
14	FD-GZ14-	29.9(1.18)	24.4(0.96)	25.0(0.98)	24.0(0.94)
15	FD-GZ15-	29.9(1.18)	24.4(0.96)	25.0(0.98)	24.0(0.94)
16	FD-GZ16-	29.9(1.18)	24.4(0.96)	25.0(0.98)	24.0(0.94)
18	FD-GZ18-	31.4(1.24)	24.4(0.96)	30.0(1.18)	27.0(1.06)
20	FD-GZ20-	34.0(1.34)	26.0(1.02)	32.0(1.26)	30.0(1.18)
22	FD-GZ22-	34.0(1.34)	26.0(1.02)	32.0(1.26)	30.0(1.18)
25	FD-GZ25-	38.5(1.52)	31.3(1.23)	38.0(1.50)	35.0(1.38)
28	FD-GZ28-	48.5(1.91)	36.6(1.44)	46.0(1.81)	41.0(1.61)
30	FD-GZ30-	53.4(2.10)	39.6(1.56)	50.0(1.97)	46.0(1.81)
32	FD-GZ32-	55.8(2.20)	42.0(1.65)	50.0(1.97)	46.0(1.81)
38	FD-GZ38-	65.4(2.57)	49.4(1.94)	60.0(2.36)	55.0(2.17)

## Заглушка для фитинга

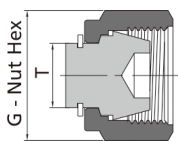

Дюймовая трубка		
Т-Трубка (in.)	Артикул	Размеры, дюйм. (мм)
		G
1/16	FDD-YZ1-	0.31(7.9)
1/8	FDD-YZ2-	0.44(11.1)
3/16	FDD-YZ3-	0.50(12.7)
1/4	FDD-YZ4-	0.56(14.3)
5/16	FDD-YZ5-	0.63(15.9)
3/8	FDD-YZ6-	0.69(17.5)
1/2	FDD-YZ8-	0.87(22.2)
5/8	FDD-YZ10-	1.00(25.4)
3/4	FDD-YZ12-	1.13(28.6)
7/8	FDD-YZ14-	1.25(31.8)
1	FDD-YZ16-	1.50(38.1)
1 1/4	FDD-YZ20-	1.87(47.6)
1 1/2	FDD-YZ24-	2.25(57.2)

Metric Tube		
Т-Трубка (in.)	Артикул	Размеры, дюйм. (мм)
		G
2	FDD-GZ2-	12.0(0.47)
3	FDD-GZ3-	12.0(0.47)
4	FDD-GZ4-	12.0(0.47)
6	FDD-GZ6-	14.0(0.55)
8	FDD-GZ8-	16.0(0.63)
10	FDD-GZ10-	19.0(0.75)
12	FDD-GZ12-	22.0(0.87)
14	FDD-GZ14-	25.0(0.98)
15	FDD-GZ15-	25.0(0.98)
16	FDD-GZ16-	25.0(0.98)
18	FDD-GZ18-	30.0(1.18)
20	FDD-GZ20-	32.0(1.26)
22	FDD-GZ22-	32.0(1.26)
25	FDD-GZ25-	38.0(1.50)
28	FDD-GZ28-	46.0(1.81)
30	FDD-GZ30-	50.0(1.97)
32	FDD-GZ32-	50.0(1.97)
38	FDD-GZ38-	60.0(2.36)

## Фильтр защитный для вентиляционных отверстий

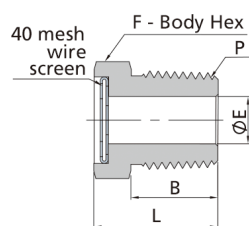

Резьба NPT					
P-NPT Резьба	Артикул	размеры, дюйм. (мм)			
		L	F	B	E
1/8	FF-NPT2-	0.56(14.2)	0.50(12.7)	0.38(9.7)	0.19(4.8)
1/4	FF-NPT4-	0.78(19.8)	0.56(14.3)	0.56(14.2)	0.28(7.1)
3/8	FF-NPT6-	0.81(20.6)	0.69(17.5)	0.56(14.2)	0.41(10.4)
1/2	FF-NPT8-	1.03(26.2)	0.87(22.2)	0.75(19.1)	0.50(12.7)
3/4	FF-NPT12-	1.06(26.9)	1.06(27.0)	0.76(19.2)	0.72(18.3)
1	FF-NPT16-	1.37(34.8)	1.37(34.9)	0.94(23.9)	0.88(22.4)

## Соединитель лабораторных фланцев

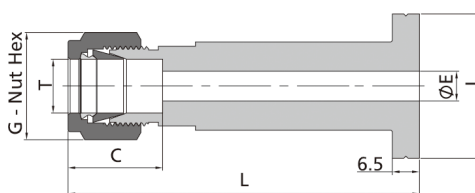

- Стандартный материал 316L или Монель.
- The flange ends are used with NPS 1/2 lap joint pipe flanges.
- ASME B16.5 Class 2500
- Фланцево уплотнение А означает чистоту поверхности Ra 3.2- 6.3 м, фланцевое уплотнение В означает Ra 6.3-12.5 м .

Резьба NPT							
Т-Трубка. (in.)	Уплотн фланца	Артикул	Размеры, дюйм. (мм)				
			L	G	C	E	J
1/4	A	FUU-YZ4A-	3.18(80.8)	0.56(14.3)	0.60(15.2)	0.19(4.8)	1.36(34.5)
1/4	B	FUU-YZ4B-	3.18(80.8)	0.56(14.3)	0.60(15.2)	0.19(4.8)	1.36(34.5)
3/8	A	FUU-YZ6A-	3.24(82.3)	0.69(17.5)	0.66(16.8)	0.28(7.1)	1.36(34.5)
3/8	B	FUU-YZ6B-	3.24(82.3)	0.69(17.5)	0.66(16.8)	0.28(7.1)	1.36(34.5)
1/2	A	FUU-YZ8A-	3.35(85.1)	0.87(22.2)	0.90(22.9)	0.31(7.9)	1.36(34.5)
1/2	B	FUU-YZ8B-	3.35(85.1)	0.87(22.2)	0.90(22.9)	0.31(7.9)	1.36(34.5)

Metric Tube							
Т-Трубка. (in.)	Уплотн фланца	Артикул	Размеры, дюйм. (мм)				
			L	G	C	E	J
10	A	FUU-GZ10A-	82.6(3.25)	19.0(0.75)	17.2(0.68)	7.9(0.31)	34.5(1.36)
10	B	FUU-GZ10B-	82.6(3.25)	19.0(0.75)	17.2(0.68)	7.9(0.31)	34.5(1.36)

# Размеры

## Гайка

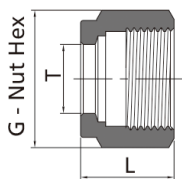

### Дюймовая трубка

Т-Трубка (in.)	Артикул	Размеры, дюйм. (мм)	
		L	G
1/16	FW-YZ1-	0.31(7.9)	0.31(7.9)
1/8	FW-YZ2-	0.47(11.9)	0.44(11.1)
3/16	FW-YZ3-	0.47(11.9)	0.50(12.7)
1/4	FW-YZ4-	0.50(12.7)	0.56(14.3)
5/16	FW-YZ5-	0.53(13.5)	0.63(15.9)
3/8	FW-YZ6-	0.56(14.2)	0.69(17.5)
1/2	FW-YZB-	0.69(17.5)	0.87(22.2)
5/8	FW-YZ10-	0.69(17.5)	1.00(25.4)
3/4	FW-YZ12-	0.69(17.5)	1.13(28.6)
7/8	FW-YZ14-	0.69(17.5)	1.25(31.8)
1	FW-YZ16-	0.81(20.6)	1.50(38.1)
1 1/8	FW-YZ18-	1.21(30.8)	1.75(44.5)
1 1/4	FW-YZ20-	1.25(31.8)	1.87(47.6)
1 1/2	FW-YZ24-	1.50(38.1)	2.25(57.2)

### Metric Tube

Т-Трубка (мм.)	Артикул	Размеры, дюйм. (мм)	
		L	G
2	FW-GZ2-	11.9(0.47)	12.0(0.47)
3	FW-GZ3-	11.9(0.47)	12.0(0.47)
4	FW-GZ4-	11.9(0.47)	12.0(0.47)
6	FW-GZ6-	12.7(0.50)	14.0(0.55)
8	FW-GZB-	13.5(0.53)	16.0(0.63)
10	FW-GZ10-	15.1(0.59)	19.0(0.75)
12	FW-GZ12-	17.4(0.69)	22.0(0.87)
14	FW-GZ14-	17.4(0.69)	25.0(0.98)
15	FW-GZ15-	17.4(0.69)	25.0(0.98)
16	FW-GZ16-	17.4(0.69)	25.0(0.98)
18	FW-GZ18-	17.4(0.69)	30.0(1.18)
20	FW-GZ20-	17.4(0.69)	32.0(1.26)
22	FW-GZ22-	17.4(0.69)	32.0(1.26)
25	FW-GZ25-	20.6(0.81)	38.0(1.50)
28	FW-GZ28-	30.6(1.20)	46.0(1.81)
30	FW-GZ30-	32.7(1.29)	50.0(1.97)
32	FW-GZ32-	34.4(1.35)	50.0(1.97)
38	FW-GZ38-	40.6(1.60)	60.0(2.36)

## Гайка с накаткой

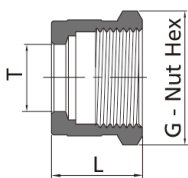

Для заказа гайки с накаткой, необходимо к артикулу добавить символ **J**

Пример: FWJ-YZ8-SS

## Гайка с наружной резьбой

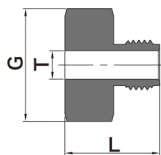

### Дюймовая трубка

Т-Трубка (in.)	Артикул	Размеры, дюйм. (мм)	
		L	G
1/16	FWM-YZ1-	0.38(9.7)	0.25(6.4)
1/8	FWM-YZ2-	0.53(13.5)	0.37(9.5)
1/4	FWM-YZ4-	0.62(15.7)	0.50(12.7)
1/2	FWM-YZ8--	0.87(22.1)	0.94(23.8)

### Метрическая трубка

Т-Трубка (мм.)	Артикул	Размеры, дюйм. (мм)	
		L	G
3	FWM-GZ3-	13.5(0.53)	10.0(0.39)
6	FWM-GZ6-	15.7(0.62)	14.0(0.55)
10	FWM-GZ10-	22.1(0.87)	22.0(0.87)
12	FWM-GZ12-	22.1(0.87)	24.0(0.94)

## Кольцо обжимное переднее

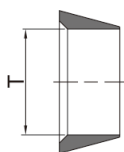

Дюймовая трубка	
Т-Трубка. (дюйм.)	Артикул
1/16	FA-YZ1-
1/8	FA-YZ2-
3/16	FA-YZ3-
1/4	FA-YZ4-
5/16	FA-YZ5-
3/8	FA-YZ6-
1/2	FA-YZ8-
5/8	FA-YZ10-
3/4	FA-YZ12-
7/8	FA-YZ14-
1	FA-YZ16-
1 1/8	FA-YZ18-
1 1/4	FA-YZ20-
1 1/2	FA-YZ24-

Метрическая трубка	
Т-Трубка (мм.)	Артикул
2	FA-GZ2-
3	FA-GZ3-
4	FA-GZ4-
6	FA-GZ6-
8	FA-GZ8-
10	FA-GZ10-
12	FA-GZ12-
14	FA-GZ14-
15	FA-GZ15-
16	FA-GZ16-
18	FA-GZ18-
20	FA-GZ20-
22	FA-GZ22-
25	FA-GZ25-
28	FA-GZ28-
30	FA-GZ30-
32	FA-GZ32-
38	FA-GZ38-

## Кольцо обжимное заднее

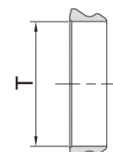

Дюймовая трубка	
Т-Трубка. (дюйм.)	Артикул
1/16	FB-YZ1-
1/8	FB-YZ2-
3/16	FB-YZ3-
1/4	FB-YZ4-
5/16	FB-YZ5-
3/8	FB-YZ6-
1/2	FB-YZ8-
5/8	FB-YZ10-
3/4	FB-YZ12-
7/8	FB-YZ14-
1	FB-YZ16-
1 1/8	FB-YZ18-
1 1/4	FB-YZ20-
1 1/2	FB-YZ24-

Метрическая трубка	
Т-Трубка (мм.)	Артикул
2	FB-GZ2-
3	FB-GZ3-
4	FB-GZ4-
6	FB-GZ6-
8	FB-GZ8-
10	FB-GZ10-
12	FB-GZ12-
14	FB-GZ14-
15	FB-GZ15-
16	FB-GZ16-
18	FB-GZ18-
20	FB-GZ20-
22	FB-GZ22-
25	FB-GZ25-
28	FB-GZ28-
30	FB-GZ30-
32	FB-GZ32-
38	FB-GZ38-

# Размеры

## Комплект обжимных колец с гайкой

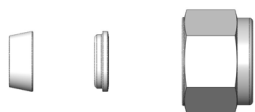

Дюймовая трубка	
Т-Трубка. (дюйм.)	Артикул
1/16	FABN-YZ1-
1/8	FABN-YZ2-
3/16	FABN-YZ3-
1/4	FABN-YZ4-
5/16	FABN-YZ5-
3/8	FABN-YZ6-
1/2	FABN-YZ8-
5/8	FABN-YZ10-
3/4	FABN-YZ12-

Метрическая трубка	
Т-Трубка (мм.)	Артикул
2	FABN-GZ2-
3	FABN-GZ3-
4	FABN-GZ4-
6	FABN-GZ6-
8	FABN-GZ8-
10	FABN-GZ10-
12	FABN-GZ12-
14	FABN-GZ14-
15	FABN-GZ15-
16	FABN-GZ16-
18	FABN-GZ18-

## Комплект обжимных колец



Дюймовая трубка	
Т-Трубка. (дюйм.)	Артикул
1/16	FAB-YZ1-
1/8	FAB-YZ2-
3/16	FAB-YZ3-
1/4	FAB-YZ4-
5/16	FAB-YZ5-
3/8	FAB-YZ6-
1/2	FAB-YZ8-
5/8	FAB-YZ10-
3/4	FAB-YZ12-

Метрическая трубка	
Т-Трубка (мм.)	Артикул
2	FAB-GZ2-
3	FAB-GZ3-
4	FAB-GZ4-
6	FAB-GZ6-
8	FAB-GZ8-
10	FAB-GZ10-
12	FAB-GZ12-
14	FAB-GZ14-
15	FAB-GZ15-
16	FAB-GZ16-
18	FAB-GZ18-



## Переходник

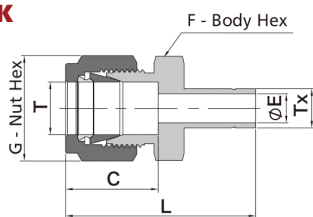

1" и ниже

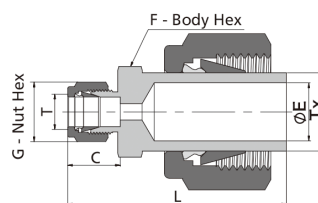

1 1/4" и выше

### Дюймовая трубка

Т-Трубка (дюйм.)	Тх-Трубка. (дюйм.)	Артикул	Размеры, дюйм. (мм)				
			L	C	G	F	E
1/16	1/8	FE-YZ1-FT2-	1.15(29.2)	0.34(8.6)	0.31(7.9)	0.31(7.9)	0.05(1.3)
1/16	3/16	FE-YZ1-FT3-	1.18(30.0)	0.34(8.6)	0.31(7.9)	0.31(7.9)	0.05(1.3)
1/16	1/4	FE-YZ1-FT4-	1.24(31.5)	0.34(8.6)	0.31(7.9)	0.31(7.9)	0.05(1.3)
1/8	1/16	FE-YZ2-FT1-	1.14(29.0)	0.50(12.7)	0.44(11.1)	0.44(11.1)	0.03(0.8)
1/8	1/8	FE-YZ2-FT2-	1.32(33.5)	0.50(12.7)	0.44(11.1)	0.44(11.1)	0.08(2.0)
1/8	3/16	FE-YZ2-FT3-	1.35(34.3)	0.50(12.7)	0.44(11.1)	0.44(11.1)	0.09(2.3)
1/8	1/4	FE-YZ2-FT4 -	1.42(36.1)	0.50(12.7)	0.44(11.1)	0.44(11.1)	0.09(2.3)
1/8	3/8	FE-YZ2-FT6-	1.48(37.6)	0.50(12.7)	0.44(11.1)	0.44(11.1)	0.09(2.3)
1/8	1/2	FE-YZ2-FT8-	1.74(44.2)	0.50(12.7)	0.44(11.1)	0.56(14.3)	0.09(2.3)
3/16	1/8	FE-YZ3-FT2-	1.37(34.8)	0.54(13.7)	0.50(12.7)	0.44(11.1)	0.08(2.0)
3/16	1/4	FE-YZ3-FT4 -	1.46(37.1)	0.54(13.7)	0.50(12.7)	0.44(11.1)	0.12(3.0)
1/4	1/8	FE-YZ4-FT2-	1.45(36.8)	0.60(15.2)	0.56(14.3)	0.50(12.7)	0.08(2.0)
1/4	3/16	FE-YZ4-FT3-	1.48(37.6)	0.60(15.2)	0.56(14.3)	0.50(12.7)	0.12(3.0)
1/4	1/4	FE-YZ4-FT4 -	1.54(39.1)	0.60(15.2)	0.56(14.3)	0.50(12.7)	0.17(4.3)
1/4	5/16	FE-YZ4-FT5-	1.57(39.9)	0.60(15.2)	0.56(14.3)	0.50(12.7)	0.19(4.8)
1/4	3/8	FE-YZ4-FT6-	1.60(40.6)	0.60(15.2)	0.56(14.3)	0.50(12.7)	0.19(4.8)
1/4	1/2	FE-YZ4-FT8-	1.82(46.2)	0.60(15.2)	0.56(14.3)	0.56(14.3)	0.19(4.8)
1/4	5/8	FE-YZ4-FT10-	1.89(48.0)	0.60(15.2)	0.56(14.3)	0.69(17.5)	0.19(4.8)
1/4	3/4	FE-YZ4-FT12-	1.88(47.8)	0.60(15.2)	0.56(14.3)	0.81(20.6)	0.19(4.8)
5/16	3/8	FE-YZ5-FT6-	1.65(41.9)	0.64(16.3)	0.63(15.9)	0.56(14.3)	0.25(6.4)
5/16	1/2	FE-YZ5-FT8-	1.87(47.5)	0.64(16.3)	0.63(15.9)	0.56(14.3)	0.25(6.4)
3/8	1/4	FE-YZ6-FT4 -	1.63(41.4)	0.66(16.8)	0.69(17.5)	0.63(15.9)	0.17(4.3)
3/8	3/8	FE-YZ6-FT6-	1.70(43.2)	0.66(16.8)	0.69(17.5)	0.63(15.9)	0.27(6.9)
3/8	1/2	FE-YZ6-FT8-	1.91(48.5)	0.66(16.8)	0.69(17.5)	0.63(15.9)	0.28(7.1)
3/8	5/8	FE-YZ6-FT10-	1.98(50.3)	0.66(16.8)	0.69(17.5)	0.69(17.5)	0.28(7.1)
3/8	3/4	FE-YZ6-FT12-	1.98(50.3)	0.66(16.8)	0.69(17.5)	0.81(20.6)	0.28(7.1)
1/2	1/4	FE-YZ8-FT4 -	1.77(45.0)	0.90(22.9)	0.87(22.2)	0.81(20.6)	0.17(4.3)
1/2	3/8	FE-YZ8-FT6-	1.84(46.7)	0.90(22.9)	0.87(22.2)	0.81(20.6)	0.27(6.9)
1/2	1/2	FE-YZ8-FT8-	2.06(52.3)	0.90(22.9)	0.87(22.2)	0.81(20.6)	0.37(9.4)
1/2	5/8	FE-YZ8-FT10-	2.12(53.8)	0.90(22.9)	0.87(22.2)	0.81(20.6)	0.41(10.4)
1/2	3/4	FE-YZ8-FT12-	2.12(53.8)	0.90(22.9)	0.87(22.2)	0.81(20.6)	0.41(10.4)
1/2	1	FE-YZ8-FT16-	2.37(60.2)	0.90(22.9)	0.87(22.2)	1.06(27.0)	0.41(10.4)
5/8	3/4	FE-YZ10-FT12-	2.15(54.6)	0.96(24.4)	1.00(25.4)	0.94(23.8)	0.50(12.7)
5/8	7/8	FE-YZ10-FT14-	2.21(56.1)	0.96(24.4)	1.00(25.4)	0.94(23.8)	0.50(12.7)
5/8	1	FE-YZ10-FT16-	2.40(61.0)	0.96(24.4)	1.00(25.4)	1.06(27.0)	0.50(12.7)
3/4	1/2	FE-YZ12-FT8-	2.15(54.6)	0.96(24.4)	1.13(28.6)	1.06(27.0)	0.37(9.4)
3/4	1	FE-YZ12-FT16-	2.46(62.5)	0.96(24.4)	1.13(28.6)	1.06(27.0)	0.62(15.7)
1	1 1/4	FE-YZ16-FT20-	3.17(80.5)	1.23(31.2)	1.50(38.1)	1.37(34.9)	0.88(22.4)
1	1 1/2	FE-YZ16-FT24-	3.51(89.2)	1.23(31.2)	1.50(38.1)	1.63(41.3)	0.88(22.4)
1	2	FE-YZ16-FT32-	4.43(112.5)	1.23(31.2)	1.50(38.1)	2.13(54.0)	0.88(22.4)
1 1/4	1 1/2	FE-YZ20-FT24-	4.10(104.1)	1.62(41.1)	1.87(47.6)	1.87(47.6)	1.09(27.7)

# Размеры

## Переходник

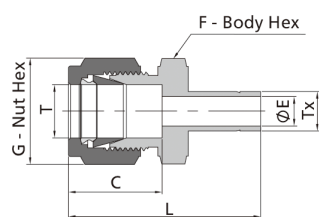

25 мм и ниже

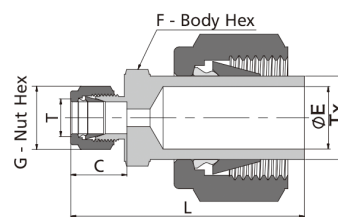

28 мм и выше

### Метрическая трубка

Т-Трубка (мм.)	Тх-Трубка. (мм.)	Артикул	Размеры, дюйм. (мм)				
			L	C	G	F	E
2	3	FE-GZ2-MT3-	33.5(1.32)	12.9(0.51)	12.0(0.47)	12.0(0.47)	1.7(0.07)
3	4	FE-GZ3-MT4-	35.0(1.38)	12.9(0.51)	12.0(0.47)	12.0(0.47)	2.4(0.09)
3	6	FE-GZ3-MT6-	36.1(1.42)	12.9(0.51)	12.0(0.47)	12.0(0.47)	2.4(0.09)
3	10	FE-GZ3-MT10-	38.4(1.51)	12.9(0.51)	12.0(0.47)	14.0(0.55)	2.4(0.09)
4	6	FE-GZ4-MT6-	37.1(1.46)	13.7(0.54)	12.0(0.47)	12.0(0.47)	2.4(0.09)
6	3	FE-GZ6-MT3-	36.9(1.45)	15.3(0.60)	14.0(0.55)	14.0(0.55)	1.9(0.07)
6	8	FE-GZ6-MT8-	39.9(1.57)	15.3(0.60)	14.0(0.55)	14.0(0.55)	4.8(0.19)
6	10	FE-GZ6-MT10-	40.7(1.60)	15.3(0.60)	14.0(0.55)	14.0(0.55)	4.8(0.19)
6	12	FE-GZ6-MT12-	46.3(1.82)	15.3(0.60)	14.0(0.55)	14.0(0.55)	4.8(0.19)
6	18	FE-GZ6-MT18-	49.6(1.95)	15.3(0.60)	14.0(0.55)	22.0(0.87)	4.8(0.19)
8	6	FE-GZ8-MT6-	40.3(1.59)	16.2(0.64)	16.0(0.63)	15.0(0.59)	4.1(0.16)
8	10	FE-GZ8-MT10-	42.0(1.65)	16.2(0.64)	16.0(0.63)	15.0(0.59)	6.4(0.25)
8	12	FE-GZ8-MT12-	47.6(1.87)	16.2(0.64)	16.0(0.63)	15.0(0.59)	6.4(0.25)
10	6	FE-GZ10-MT6-	42.4(1.67)	17.2(0.68)	19.0(0.75)	18.0(0.71)	4.1(0.16)
10	8	FE-GZ10-MT8-	43.4(1.71)	17.2(0.68)	19.0(0.75)	18.0(0.71)	5.6(0.22)
10	12	FE-GZ10-MT12-	49.8(1.96)	17.2(0.68)	19.0(0.75)	18.0(0.71)	7.9(0.31)
10	15	FE-GZ10-MT15-	51.3(2.02)	17.2(0.68)	19.0(0.75)	18.0(0.71)	7.9(0.31)
10	18	FE-GZ10-MT18-	51.3(2.02)	17.2(0.68)	19.0(0.75)	22.0(0.87)	7.9(0.31)
12	6	FE-GZ12-MT6-	44.9(1.77)	22.8(0.90)	22.0(0.87)	22.0(0.87)	4.1(0.16)
12	8	FE-GZ12-MT8-	45.9(1.81)	22.8(0.90)	22.0(0.87)	22.0(0.87)	5.6(0.22)
12	10	FE-GZ12-MT10-	46.7(1.84)	22.8(0.90)	22.0(0.87)	22.0(0.87)	7.1(0.28)
12	16	FE-GZ12-MT16-	53.8(2.12)	22.8(0.90)	22.0(0.87)	22.0(0.87)	9.5(0.37)
12	18	FE-GZ12-MT18-	53.8(2.12)	22.8(0.90)	22.0(0.87)	22.0(0.87)	9.5(0.37)
12	20	FE-GZ12-MT20-	56.1(2.21)	22.8(0.90)	22.0(0.87)	22.0(0.87)	9.5(0.37)
12	22	FE-GZ12-MT22-	56.1(2.21)	22.8(0.90)	22.0(0.87)	24.0(0.94)	9.5(0.37)
12	25	FE-GZ12-MT25-	62.4(2.46)	22.8(0.90)	22.0(0.87)	27.0(1.06)	9.5(0.37)
16	12	FE-GZ16-MT12-	53.0(2.09)	24.4(0.96)	25.0(0.98)	24.0(0.94)	8.8(0.35)
18	12	FE-GZ18-MT12-	54.6(2.15)	24.4(0.96)	30.0(1.18)	27.0(1.06)	8.8(0.35)
18	16	FE-GZ18-MT16-	56.1(2.21)	24.4(0.96)	30.0(1.18)	27.0(1.06)	12.0(0.47)
18	20	FE-GZ18-MT20-	57.6(2.27)	24.4(0.96)	30.0(1.18)	27.0(1.06)	15.1(0.59)
18	22	FE-GZ18-MT22-	57.6(2.27)	24.4(0.96)	30.0(1.18)	27.0(1.06)	15.1(0.59)
18	25	FE-GZ18-MT25-	62.4(2.46)	24.4(0.96)	30.0(1.18)	27.0(1.06)	15.1(0.59)
20	16	FE-GZ20-MT16-	57.9(2.28)	26.0(1.02)	32.0(1.26)	30.0(1.18)	12.0(0.47)
20	18	FE-GZ20-MT18-	57.9(2.28)	26.0(1.02)	32.0(1.26)	30.0(1.18)	13.9(0.55)
20	22	FE-GZ20-MT22-	59.4(2.34)	26.0(1.02)	32.0(1.26)	30.0(1.18)	15.9(0.63)
20	25	FE-GZ20-MT25-	64.2(2.53)	26.0(1.02)	32.0(1.26)	30.0(1.18)	15.8(0.62)
22	18	FE-GZ22-MT18-	57.9(2.28)	26.0(1.02)	32.0(1.26)	30.0(1.18)	13.9(0.55)
22	20	FE-GZ22-MT20-	59.4(2.34)	26.0(1.02)	32.0(1.26)	30.0(1.18)	15.5(0.61)
22	25	FE-GZ22-MT25-	64.2(2.53)	26.0(1.02)	32.0(1.26)	30.0(1.18)	18.3(0.72)
25	18	FE-GZ25-MT18-	63.1(2.48)	31.3(1.23)	38.0(1.50)	35.0(1.38)	13.9(0.55)
25	20	FE-GZ25-MT20-	64.6(2.54)	31.3(1.23)	38.0(1.50)	35.0(1.38)	15.5(0.61)

## Переходник

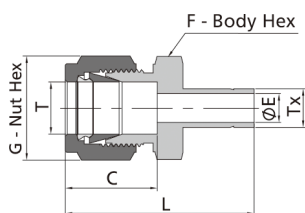

### Метрическая трубка

### Дюймовая трубка

Т-Трубка (мм.)	Тх-Трубка. (дюйм.)	Артикул	Размеры, дюйм. (мм)				
			L	C	G	F	E
2	1/8	FE-GZ2-FT2-	33.5(1.32)	12.9(0.51)	12.0(0.47)	12.0(0.47)	1.7(0.07)
3	1/8	FE-GZ3-FT2-	33.5(1.32)	12.9(0.51)	12.0(0.47)	12.0(0.47)	2.0(0.08)
3	1/4	FE-GZ3-FT4-	36.1(1.42)	12.9(0.51)	12.0(0.47)	12.0(0.47)	2.4(0.09)
4	1/4	FE-GZ4-FT4-	37.1(1.46)	13.7(0.54)	12.0(0.47)	12.0(0.47)	2.4(0.09)
6	1/8	FE-GZ6-FT2-	36.9(1.45)	15.3(0.60)	14.0(0.55)	14.0(0.55)	2.0(0.08)
6	1/4	FE-GZ6-FT4-	39.2(1.54)	15.3(0.60)	14.0(0.55)	14.0(0.55)	4.4(0.17)
6	5/16	FE-GZ6-FT5-	39.9(1.57)	15.3(0.60)	14.0(0.55)	14.0(0.55)	4.8(0.19)
6	3/8	FE-GZ6-FT6-	40.7(1.60)	15.3(0.60)	14.0(0.55)	14.0(0.55)	4.8(0.19)
6	1/2	FE-GZ6-FT8-	46.3(1.82)	15.3(0.60)	14.0(0.55)	14.0(0.55)	4.8(0.19)
8	1/4	FE-GZ8-FT4-	40.3(1.59)	16.2(0.64)	16.0(0.63)	15.0(0.59)	4.4(0.17)
8	3/8	FE-GZ8-FT6-	42.0(1.65)	16.2(0.64)	16.0(0.63)	15.0(0.59)	6.4(0.25)
8	1/2	FE-GZ8-FT8-	47.6(1.87)	16.2(0.64)	16.0(0.63)	15.0(0.59)	6.4(0.25)
10	3/8	FE-GZ10-FT6-	44.4(1.75)	17.2(0.68)	19.0(0.75)	18.0(0.71)	6.8(0.27)
10	1/2	FE-GZ10-FT8-	49.8(1.96)	17.2(0.68)	19.0(0.75)	18.0(0.71)	7.9(0.31)
12	1/2	FE-GZ12-FT8-	52.3(2.06)	22.8(0.90)	22.0(0.87)	22.0(0.87)	9.3(0.37)
12	3/4	FE-GZ12-FT12-	53.8(2.12)	22.8(0.90)	22.0(0.87)	22.0(0.87)	9.5(0.37)
18	3/4	FE-GZ18-FT12-	56.1(2.21)	24.4(0.96)	30.0(1.18)	27.0(1.06)	14.7(0.58)
18	1	FE-GZ18-FT16-	62.4(2.46)	24.4(0.96)	30.0(1.18)	27.0(1.06)	15.1(0.59)
25	1	FE-GZ25-FT16-	69.5(2.74)	31.3(1.23)	38.0(1.50)	35.0(1.38)	20.2(0.80)

### Дюймовая трубка

### Метрическая трубка

Т-Трубка (дюйм.)	Тх-Трубка. (мм.)	Артикул	Размеры, дюйм. (мм)				
			L	C	G	F	E
1/8	6	HJKG-YZ2-MT6-	1.42(36.1)	0.50(12.7)	0.44(11.1)	0.44(11.1)	0.09(2.3)

## Переходник с монтажной гайкой

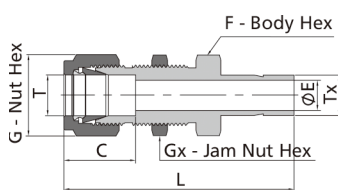

### Fractional Tube

Т-Трубка (in.)	Тх-Трубка. (in.)	Артикул	Размеры, дюймы. (мм)					
			L	C	G	F	Gx	E
1/8	1/8	FEN-YZ2-FT2-	1.95(49.5)	0.50(12.7)	0.44(11.1)	0.50(12.7)	0.50(12.7)	0.08(2.0)
1/4	1/4	FEN-YZ4-FT4-	2.20(55.9)	0.60(15.2)	0.56(14.3)	0.63(15.9)	0.63(15.9)	0.17(4.3)
3/8	3/8	FEN-YZ6-FT6-	2.41(61.2)	0.66(16.8)	0.69(17.5)	0.75(19.1)	0.75(19.1)	0.27(6.9)
1/2	1/2	FEN-YZ8-FT8-	2.87(72.9)	0.90(22.9)	0.87(22.2)	0.94(23.8)	0.94(23.8)	0.37(9.4)
5/8	5/8	FEN-YZ10-FT10-	2.96(75.2)	0.96(24.4)	1.00(25.4)	1.06(27.0)	1.06(27.0)	0.47(11.9)
3/4	3/4	FEN-YZ12-FT12-	3.21(81.5)	0.96(24.4)	1.13(28.6)	1.19(30.2)	1.19(30.2)	0.58(14.7)
1	1	FEN-YZ16-FT16-	3.95(100.3)	1.23(31.2)	1.50(38.1)	1.63(41.3)	1.63(41.3)	0.80(20.3)

## Угольник переходной трубный

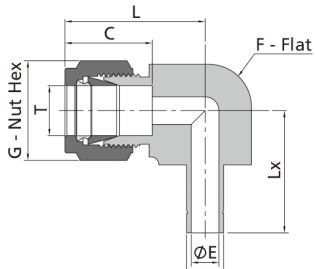

### Metric Tube

Т-Трубка (мм.)	Тх-Трубка. (мм.)	Артикул	Размеры, дюймы. (мм)					
			L	C	G	F	E	Lx
6	6	FEY-GZ6-MT6-	27.0(1.06)	15.3(0.60)	14.0(0.55)	12.7(0.50)	4.1(0.16)	25.0(0.98)
12	12	FEY-GZ12-MT12-	38.1(1.50)	22.8(0.90)	22.0(0.87)	23.8(0.94)	8.8(0.35)	39.2(1.54)

## Втулка для гибких трубок

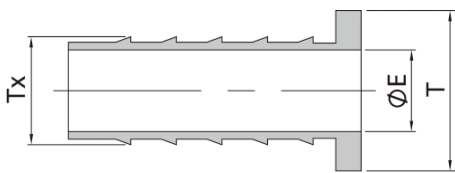

Вставка для мягких пластиковых трубок используется для защиты мягких пластиковых трубок, используемых с трубными фитингами. Чтобы определить правильный размер вставки для мягкой пластиковой трубки, сначала следует определить внешний и внутренний диаметр мягкой пластиковой трубки.

### Дюймовая трубка

Т-Трубка (дюйм.)	Тх-Трубка (дюйм.)	Артикул	Е дюйм. (мм)
3/16	1/8	FEX-3-2-	0.09(2.3)
1/4	1/8	FEX-4-2-	0.09(2.3)
1/4	0.17	FEX-4-017-	0.11(2.8)
1/4	3/16	FEX-4-3-	0.14(3.5)
5/16	1/8	FEX-5-2-	0.09(2.3)
5/16	3/16	FEX-5-3-	0.12(3.0)
5/16	1/4	FEX-5-4-	0.19(4.8)
3/8	3/16	FEX-6-3-	0.12(3.0)
3/8	1/4	FEX-6-4-	0.19(4.8)
1/2	1/4	FEX-8-4-	0.19(4.8)
1/2	3/8	FEX-8-6-	0.31(7.9)
5/8	3/8	FEX-10-6-	0.31(7.9)
5/8	1/2	FEX-10-8-	0.44(11.1)
3/4	1/2	FEX-12-8-	0.44(11.1)
3/4	5/8	FEX-12-10-	0.56(14.2)
1	3/4	FEX-16-12-	0.69(17.5)

### Метрическая Трубка

Т-Трубка (мм.)	Тх-Трубка (мм.)	Артикул	Е дюйм. (мм)
6	4	FEX-6M-4M-	2.8(0.11)
8	6	FEX-8M-6M-	4.4(0.17)
10	8	FEX-10M-8M-	6.4(0.25)
12	8	FEX-12M-8M-	6.4(0.25)
12	10	FEX-12M-10M-	8.3(0.33)

## Соединение для проходного канала

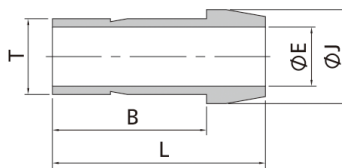

1" / 25 мм и ниже

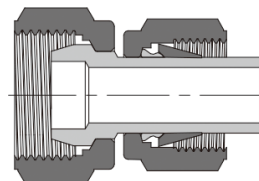

1 1/4" / 28 мм и выше

### Дюймовая трубка

Т-Трубка (in.)	Артикул	Размеры, дюйм. (мм)			
		L	B	E	J
1/16	FEP-YZ1-	0.54(13.7)	0.42(10.7)	0.03(0.8)	0.13(3.3)
1/8	FEP-YZ2-	0.88(22.4)	0.62(15.7)	0.08(2.0)	0.24(6.1)
1/4	FEP-YZ4-	0.97(24.6)	0.74(18.8)	0.17(4.3)	0.37(9.4)
5/16	FEP-YZ5-	1.02(25.9)	0.79(20.1)	0.22(5.6)	0.43(10.9)
3/8	FEP-YZ6-	1.03(26.2)	0.80(20.3)	0.27(6.9)	0.50(12.7)
1/2	FEP-YZ8-	1.41(35.8)	1.02(25.9)	0.37(9.4)	0.62(15.7)
5/8	FEP-YZ10-	1.64(41.7)	1.11(28.1)	0.47(11.9)	0.81(20.5)
3/4	FEP-YZ12-	1.65(41.9)	1.09(27.7)	0.58(14.7)	0.87(22.1)
1	FEP-YZ16-	1.89(48.0)	1.36(34.5)	0.80(20.3)	1.12(28.4)
1 1/4	FEP-YZ20-	2.72(69.1)	1.99(50.6)	1.02(25.9)	1.47(37.4)
1 1/2	FEP-YZ24-	3.48(88.4)	2.5(63.6)	1.24(31.5)	1.85(47.0)

### Метрическая трубка

Т-Трубка (мм.)	Артикул	Размеры, дюйм. (мм)			
		L	B	E	J
3	FEP-GZ3-	22.2(0.87)	15.7(0.62)	1.9(0.07)	6.0(0.24)
6	FEP-GZ6-	24.6(0.97)	18.7(0.74)	4.1(0.16)	9.0(0.35)
8	FEP-GZ8-	25.9(1.02)	20.0(0.79)	5.6(0.22)	11.0(0.43)
10	FEP-GZ10-	26.1(1.03)	20.2(0.80)	7.1(0.28)	13.1(0.52)
12	FEP-GZ12-	35.8(1.41)	26.0(1.02)	8.8(0.35)	15.0(0.59)
15	FEP-GZ15-	37.8(1.49)	27.6(1.09)	11.2(0.44)	19.6(0.77)
16	FEP-GZ16-	37.8(1.49)	27.6(1.09)	12.0(0.47)	20.6(0.81)
18	FEP-GZ18-	37.8(1.49)	27.7(1.09)	13.9(0.55)	21.0(0.83)
20	FEP-GZ20-	39.4(1.55)	29.2(1.15)	15.5(0.61)	24.6(0.97)
25	FEP-GZ25-	49.3(1.94)	34.5(1.36)	19.9(0.78)	31.2(1.23)
28	FEP-GZ28-	63.5(2.5)	48.3(1.90)	22.5(0.89)	34.4(1.35)
30	FEP-GZ30-	67.6(2.66)	52.2(2.06)	24.3(0.96)	37.4(1.47)
32	FEP-GZ32-	69.7(2.74)	52.4(2.06)	26.5(1.04)	39.4(1.55)
38	FEP-GZ38-	81.9(3.22)	61.4(2.42)	31.6(1.24)	45.8(1.80)

## Переходник для проходного канала

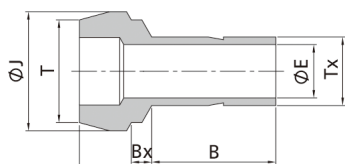

1 "/25мм и ниже

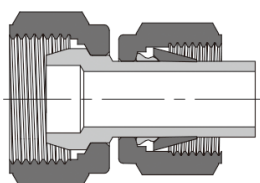

1 1/4" /28 мм и выше

### Дюймовая трубка

Т-Трубка (in.)	Тх-Трубка. (in.)	Артикул	Размеры, дюйм. (мм.)				
			L	B	E	Bx	J
1/8	1/16	FER-YZ2-YZ1-	0.68(17.3)	0.34(8.6)	0.03(0.8)	0.08(2.0)	0.24(6.1)
1/4	1/16	FER-YZ4-YZ1-	0.71(18.0)	0.34(8.6)	0.03(0.8)	0.14(3.6)	0.37(9.4)
1/4	1/8	FER-YZ4-YZ2-	0.89(22.6)	0.53(13.5)	0.08(2.0)	0.13(3.3)	0.37(9.4)
3/8	1/8	FER-YZ6-YZ2-	0.91(23.1)	0.53(13.5)	0.08(2.0)	0.15(3.8)	0.50(12.7)
3/8	1/4	FER-YZ6-YZ4-	0.98(24.9)	0.62(15.7)	0.17(4.3)	0.13(3.3)	0.50(12.7)
1/2	1/4	FER-YZ8-YZ4-	1.15(29.2)	0.62(15.7)	0.17(4.3)	0.15(3.8)	0.62(15.7)
1/2	3/8	FER-YZ8-YZ6-	1.20(30.5)	0.69(17.5)	0.27(6.9)	0.13(3.3)	0.62(15.7)
3/4	1/2	FER-YZ12-YZ8-	1.49(37.8)	0.91(23.1)	0.37(9.4)	0.15(3.8)	0.87(22.1)
1	1/2	FER-YZ16-YZ8-	1.69(42.9)	0.96(24.4)	0.37(9.4)	0.19(4.8)	1.12(28.5)
1	3/4	FER-YZ16-YZ12-	1.72(43.7)	1.02(25.9)	0.58(14.7)	0.16(4.1)	1.12(28.5)

### Метрическая трубка

Т-Трубка (мм.)	Тх-Трубка. (мм.)	Артикул	Размеры, дюйм. (мм.)				
			L	B	E	Bx	J
6	3	FER-GZ6-GZ3-	22.6(0.89)	13.5(0.53)	1.9(0.07)	3.2(0.13)	9.0(0.35)
8	6	FER-GZ8-GZ6-	24.7(0.97)	15.7(0.62)	4.1(0.16)	3.1(0.12)	11.0(0.43)
10	6	FER-GZ10-GZ6-	25.0(0.98)	15.7(0.62)	4.1(0.16)	3.4(0.13)	13.1(0.52)
10	8	FER-GZ10-GZ8-	26.3(1.04)	17.0(0.67)	5.6(0.22)	3.1(0.12)	13.1(0.52)
12	6	FER-GZ12-GZ6-	29.6(1.17)	15.7(0.62)	4.1(0.16)	3.6(0.14)	15.0(0.59)
12	8	FER-GZ12-GZ8-	29.8(1.17)	16.8(0.66)	5.6(0.22)	3.4(0.13)	15.0(0.59)
12	10	FER-GZ12-GZ10-	30.4(1.20)	17.5(0.69)	7.1(0.28)	3.1(0.12)	15.0(0.59)
16	12	FER-GZ16-GZ12-	36.2(1.43)	23.1(0.91)	8.8(0.35)	3.4(0.13)	19.0(0.75)
28	25	FER-GZ28-GZ25-	56.5(2.22)	33.0(1.30)	19.8(0.78)	8.2(0.32)	34.3(1.35)
32	25	FER-GZ32-GZ25-	60.3(2.37)	33.0(1.30)	19.8(0.78)	9.9(0.39)	39.5(1.56)
38	25	FER-GZ3S-GZ25-	65.8(2.59)	33.0(1.30)	19.8(0.78)	12.3(0.48)	47.1(1.85)

# Размеры

## Переходник с наружной резьбой

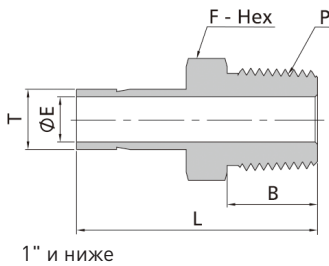

1" и ниже

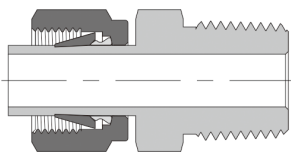

1 1/4" и выше

Размер E наименьший номинальный размер.

### Дюймовая трубка

### Резьба NPT

Т-Трубка (in.)	Р-NPT Резьба	Артикул	Размеры, дюйм. (мм.)			
			L	B	E	F
1/16	1/8	FEM-FT1-NPT2-	1.00(25.4)	0.38(9.7)	0.03(0.8)	0.44(11.1)
1/8	1/8	FEM-FT2-NPT2-	1.16(29.5)	0.38(9.7)	0.08(2.0)	0.44(11.1)
1/8	1/4	FEM-FT2-NPT4-	1.37(34.8)	0.56(14.2)	0.08(2.0)	0.56(14.3)
3/16	1/8	FEM-FT3-NPT2-	1.19(30.2)	0.38(9.7)	0.12(3.0)	0.44(11.1)
3/16	1/4	FEM-FT3-NPT4-	1.40(35.6)	0.56(14.2)	0.12(3.0)	0.56(14.3)
1/4	1/8	FEM-FT 4-NPT2-	1.25(31.8)	0.38(9.7)	0.17(4.3)	0.44(11.1)
1/4	1/4	FEM-FT4-NPT4-	1.46(37.1)	0.56(14.2)	0.17(4.3)	0.56(14.3)
1/4	3/8	FEM-FT 4-NPT6-	1.49(37.8)	0.56(14.2)	0.17(4.3)	0.69(17.5)
1/4	1/2	FEM-FT 4-NPT8-	1.71(43.4)	0.75(19.1)	0.17(4.3)	0.87(22.2)
5/16	1/8	FEM-FT5-NPT2-	1.29(32.8)	0.38(9.7)	0.19(4.8)	0.44(11.1)
5/16	1/4	FEM-FT5-NPT4-	1.50(38.1)	0.56(14.2)	0.22(5.6)	0.56(14.3)
5/16	3/8	FEM-FT5-NPT6-	1.53(38.9)	0.56(14.2)	0.22(5.6)	0.69(17.5)
5/16	1/2	FEM-FT5-NPT8-	1.74(44.2)	0.75(19.1)	0.22(5.6)	0.87(22.2)
3/8	1/8	FEM-FT6-NPT2-	1.32(33.5)	0.38(9.7)	0.19(4.8)	0.44(11.1)
3/8	1/4	FEM-FT6-NPT4-	1.53(38.9)	0.56(14.2)	0.27(6.9)	0.56(14.3)
3/8	3/8	FEM-FT6-NPT6-	1.56(39.6)	0.56(14.2)	0.27(6.9)	0.69(17.5)
3/8	1/2	FEM-FT6-NPT8-	1.78(45.2)	0.75(19.1)	0.27(6.9)	0.87(22.2)
1/2	1/4	FEM-FT8-NPT4-	1.75(44.5)	0.56(14.2)	0.28(7.1)	0.56(14.3)
1/2	3/8	FEM-FT8-NPT6-	1.78(45.2)	0.56(14.2)	0.37(9.4)	0.69(17.5)
1/2	1/2	FEM-FT8-NPT8-	2.00(50.8)	0.75(19.1)	0.37(9.4)	0.87(22.2)
5/8	1/2	FEM-FT1 0-NPT8-	2.06(52.3)	0.75(19.1)	0.47(11.9)	0.87(22.2)
3/4	1/2	FEM-FT12-NPT8-	2.06(52.3)	0.75(19.1)	0.47(11.9)	0.87(22.2)
3/4	3/4	FEM-FT12-NPT12-	2.06(52.3)	0.75(19.1)	0.58(14.7)	1.06(27.0)
3/4	1	FEM-FT12-NPT16-	2.41(61.2)	0.94(23.9)	0.58(14.7)	1.37(34.9)
1	3/4	FEM-FT16-NPT12-	2.31(58.7)	0.75(19.1)	0.62(15.7)	1.06(27.0)
1	1	FEM-FT16-NPT16-	2.60(66.0)	0.94(23.9)	0.80(20.3)	1.37(34.9)
1 1/4	1 1/4	FEM-FT20-NPT20-	3.16(80.3)	0.94(23.9)	1.02(25.9)	1.75(44.5)
1 1/2	1 1/2	FEM-FT24-NPT24-	3.72(94.5)	1.03(26.2)	1.25(31.8)	2.13(54.0)

### Дюймовая трубка

### Коническая резьба ISO (RT)

Т-Трубка (in.)	Р-RT Резьба	Артикул	Размеры, дюйм. (мм.)			
			L	B	E	F
1/8	1/8	FEM-FT2-RT2-	1.16(29.5)	0.38(9.7)	0.08(2.0)	0.44(11.1)
1/8	1/4	FEM-FT2-RT4-	1.37(34.8)	0.56(14.2)	0.08(2.0)	0.56(14.3)
1/4	1/8	FEM-FT4-RT2-	1.25(31.8)	0.38(9.7)	0.17(4.3)	0.44(11.1)
1/4	1/4	FEM-FT4-RT4-	1.46(37.1)	0.56(14.2)	0.17(4.3)	0.56(14.3)
1/4	3/8	FEM-FT4-RT6-	1.49(37.8)	0.56(14.2)	0.17(4.3)	0.69(17.5)
1/4	1/2	FEM-FT4-RT8-	1.71(43.4)	0.75(19.1)	0.17(4.3)	0.87(22.2)
5/16	1/8	FEM-FT5-RT2-	1.29(32.8)	0.38(9.7)	0.19(4.8)	0.44(11.1)
5/16	1/4	FEM-FT5-RT4-	1.50(38.1)	0.56(14.2)	0.22(5.6)	0.56(14.3)
3/8	1/4	FEM-FT6-RT4-	1.53(38.9)	0.56(14.2)	0.27(6.9)	0.56(14.3)
3/8	3/8	FEM-FT6-RT6-	1.56(39.6)	0.56(14.2)	0.27(6.9)	0.69(17.5)
3/8	1/2	FEM-FT6-RT8-	1.78(45.2)	0.75(19.1)	0.27(6.9)	0.87(22.2)
1/2	1/4	FEM-FT8-RT4-	1.75(44.5)	0.56(14.2)	0.28(7.1)	0.56(14.3)
1/2	3/8	FEM-FT8-RT6-	1.78(45.2)	0.56(14.2)	0.37(9.4)	0.69(17.5)
1/2	1/2	FEM-FT8-RT8-	2.00(50.8)	0.75(19.1)	0.37(9.4)	0.87(22.2)
5/8	3/8	FEM-FT10-RT6-	1.91(48.5)	0.56(14.2)	0.37(9.5)	0.69(17.5)
5/8	1/2	FEM-FT10-RT8-	2.06(52.3)	0.75(19.1)	0.47(11.9)	0.87(22.2)
3/4	3/4	FEM-FT12-RT12-	2.06(52.3)	0.75(19.1)	0.58(14.7)	1.06(27.0)
1	1	FEM-FT16-RT16-	2.60(66.0)	0.94(23.9)	0.80(20.3)	1.37(34.9)

## Переходник с наружной резьбой

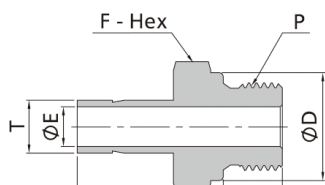

Размер E наименьший номинальный размер.

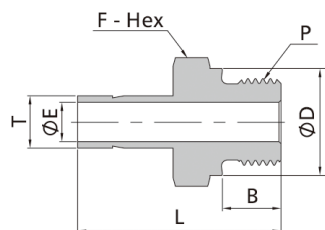

Размер E наименьший номинальный размер.

### Дюймовая трубка

### Цилиндрическая резьба ISO (RS)

Т-Трубка (in.)	P-RS Резьба	Артикул	Размеры, дюйм. (мм.)				
			L	B	E	F	D
1/8	1/8	FEM-FT2-RS2-	1.22(31.0)	0.28(7.1)	0.08(2.0)	0.56(14.3)	0.54(13.7)
1/8	1/4	FEM-FT2-RS4-	1.41(35.8)	0.44(11.2)	0.08(2.0)	0.75(19.1)	0.70(17.8)
1/4	1/8	FEM-FT4-RS2-	1.31(33.3)	0.28(7.1)	0.16(4.1)	0.56(14.3)	0.54(13.7)
1/4	1/4	FEM-FT4-RS4-	1.50(38.1)	0.44(11.2)	0.17(4.3)	0.75(19.1)	0.70(17.8)
3/8	1/8	FEM-FT6-RS2-	1.29(32.8)	0.28(7.1)	0.16(4.1)	0.56(14.3)	0.54(13.7)
3/8	1/4	FEM-FT6-RS4-	1.57(39.9)	0.44(11.2)	0.23(5.8)	0.75(19.1)	0.70(17.8)
3/8	3/8	FEM-FT6-RS6-	1.60(40.6)	0.44(11.2)	0.27(6.9)	0.87(22.2)	0.85(21.6)
3/8	1/2	FEM-FT6-RS8-	1.69(42.9)	0.56(14.2)	0.28(7.1)	1.06(27.0)	1.02(25.9)
1/2	1/4	FEM-FT8-RS4-	1.79(45.5)	0.44(11.2)	0.23(5.8)	0.75(19.1)	0.70(17.8)
1/2	3/8	FEM-FT8-RS6-	1.82(46.2)	0.44(11.2)	0.31(7.9)	0.87(22.2)	0.85(21.6)
1/2	1/2	FEM-FT8-RS8-	1.94(49.2)	0.56(14.2)	0.37(9.4)	1.06(27.0)	1.02(25.9)
5/8	1/2	FEM-FT10-RS8-	1.97(50.0)	0.56(14.2)	0.47(11.9)	1.06(27.0)	1.02(25.9)
3/4	3/4	FEM-FT12-RS12-	2.16(54.9)	0.63(16.0)	0.58(14.7)	1.31(33.3)	1.26(32.0)
1	1	FEM-FT16-RS16-	2.54(64.5)	0.72(18.3)	0.80(20.3)	1.63(41.3)	1.53(38.9)

### Fractional Tube

### Цилиндрическая резьба ISO (RP)

Т-Трубка (in.)	P-RP Резьба	Артикул	Размеры, дюйм. (мм.)				
			L	B	E	F	D
1/8	1/8	FEM-FT2-RP2-	1.09(27.7)	0.28(7.1)	0.08(2.0)	0.56(14.3)	0.54(13.7)
1/8	1/4	FEM-FT2-RP4-	1.31(33.3)	0.44(11.2)	0.08(2.0)	0.75(19.1)	0.70(17.8)
1/4	1/8	FEM-FT4-RP2-	1.19(30.2)	0.28(7.1)	0.16(4.1)	0.56(14.3)	0.54(13.7)
1/4	1/4	FEM-FT4-RP4-	1.50(38.1)	0.44(11.2)	0.18(4.6)	0.75(19.1)	0.70(17.8)
3/8	1/8	FEM-FT6-RP2-	1.34(34.0)	0.28(7.1)	0.16(4.1)	0.75(19.1)	0.54(13.7)
3/8	1/4	FEM-FT6-RP4-	1.47(37.3)	0.44(11.2)	0.25(6.4)	0.75(19.1)	0.70(17.8)
3/8	3/8	FEM-FT6-RP6-	1.50(38.1)	0.44(11.2)	0.27(6.9)	0.87(22.2)	0.85(21.6)
3/8	1/2	FEM-FT6-RP8-	1.69(42.9)	0.56(14.2)	0.27(6.9)	1.06(27.0)	1.02(25.9)
1/2	1/4	FEM-FT8-RP4-	1.69(42.9)	0.44(11.2)	0.25(6.4)	0.75(19.1)	0.70(17.8)
1/2	3/8	FEM-FT8-RP6-	1.72(43.7)	0.44(11.2)	0.31(7.9)	0.87(22.2)	0.85(21.6)
1/2	1/2	FEM-FT8-RP8-	1.94(49.3)	0.56(14.2)	0.37(9.4)	1.06(27.0)	1.02(25.9)
5/8	1/2	FEM-FT10-RP8-	1.97(50.0)	0.56(14.2)	0.47(11.9)	1.06(27.0)	1.02(25.9)
3/4	3/4	FEM-FT12-RP12-	2.09(53.1)	0.63(16.0)	0.58(14.7)	1.32(33.5)	1.26(32.0)
1	1	FEM-FT16-RP16-	2.49(63.3)	0.72(18.3)	0.78(19.8)	1.63(41.3)	1.53(38.9)

# Размеры

## Переходник с наружной резьбой

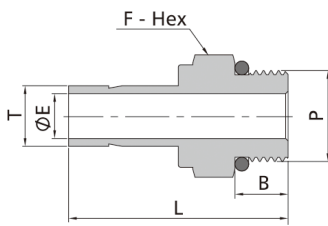

1" и ниже

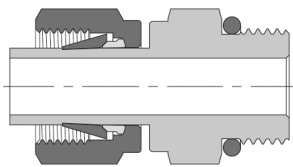

1 1/4" и выше

1. Размер E наименьший номинальный размер.

2. SAE J1926-1, ISO 11926-1 and MS 16142.

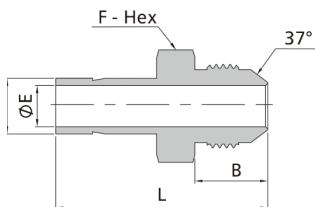

Размер E наименьший номинальный размер.

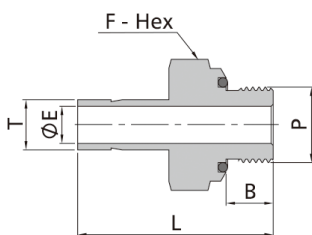

Размер E наименьший номинальный размер.

### Дюймовая трубка

### Прямая резьба SAE/MS (ST)

Т-Трубка (in.)	P-SAE Размер	P-SAE/MS Специфик. резьбы	Артикул	Размеры, дюйм. (мм.)			
				L	B	E	F
1/8	2	5/16-24	FEM-FT2-ST5-	1.20(30.5)	0.30(7.6)	0.08(2.0)	0.44(11.1)
1/4	4	7/16-20	FEM-FT4-ST7-	1.39(35.3)	0.36(9.1)	0.17(4.3)	0.56(14.3)
3/8	4	7/16-20	FEM-FT6-ST7-	1.46(37.1)	0.36(9.1)	0.20(5.1)	0.56(14.3)
3/8	6	9/16-18	FEM-FT6-ST9-	1.52(38.6)	0.39(9.9)	0.27(6.9)	0.69(17.5)
3/8	8	3/4-16	FEM-FT6-ST12-	1.60(40.6)	0.44(11.2)	0.27(6.9)	0.87(22.2)
1/2	6	9/16-18	FEM-FT8-ST9-	1.74(44.2)	0.39(9.9)	0.28(7.1)	0.69(17.5)
1/2	8	3/4-16	FEM-FT8-ST12-	1.82(46.2)	0.44(11.2)	0.37(9.4)	0.87(22.2)
5/8	10	7/8-14	FEM-FT10-ST14-	1.94(49.3)	0.50(12.7)	0.47(11.9)	1.00(25.4)
3/4	12	1 1/16-12	FEM-FT12-ST17-	2.10(53.3)	0.59(15.0)	0.58(14.7)	1.25(31.8)
1	16	5/16-12	FEM-FT16-ST21-	2.41(61.2)	0.59(15.0)	0.80(20.3)	1.50(38.1)
1 1/4	20	1 5/8-12	FEM-FT20-ST26-	2.81(71.4)	0.59(15.0)	1.02(25.9)	1.87(47.6)
1 1/2	24	1 7/8-12	FEM-FT24-ST30-	3.28(83.3)	0.59(15.0)	1.25(31.8)	2.13(54.0)

### Дюймовая трубка

### Уплотнительный конус 37° (AN)

Т-Трубка (in.)	AN Резьба	Артикул	Размеры, дюйм. (мм.)			
			L	B	E	F
1/4	1/4	FEM-FT4-AN4-	1.46(37.1)	0.55(14.0)	0.17(4.3)	0.50(12.7)
3/8	1/4	FEM-FT6-AN4-	1.53(38.9)	0.55(14.0)	0.17(4.3)	0.50(12.7)
3/8	3/8	FEM-FT6-AN6-	1.56(39.6)	0.56(14.2)	0.27(6.9)	0.63(15.9)
1/2	1/2	FEM-FT8-AN8-	1.91(48.5)	0.66(16.8)	0.37(9.4)	0.81(20.6)
3/4	3/4	FEM-FT12-AN12-	2.21(56.1)	0.86(21.8)	0.58(14.7)	1.13(28.6)
1	1	FEM-FT16-AN16-	2.58(65.5)	0.91(23.1)	0.80(20.3)	1.37(34.9)

### Дюймовая трубка

### Прямая резьба SAE/MS (OST)

Т-Трубка (in.)	P-SAE Размер	P-SAE/MS Специфик. резьбы	Артикул	Размеры, дюйм. (мм.)			
				L	B	E	F
1/8	2	5/16-24	FEM-FT2-OST5-	1.28(32.5)	0.34(8.6)	0.08(2.0)	0.56(14.3)
3/16	3	3/8-24	FEM-FT3-OST6-	1.38(35.1)	0.38(9.7)	0.12(3.0)	0.63(15.9)
1/4	4	7/16-20	FEM-FT4-OST7-	1.54(39.1)	0.41(10.4)	0.17(4.3)	0.75(19.1)
5/16	5	1/2-20	FEM-FT5-OST8-	1.64(41.7)	0.44(11.2)	0.22(5.6)	0.87(22.2)
3/8	6	9/16-18	FEM-FT6-OST9-	1.70(43.2)	0.47(11.9)	0.27(6.9)	0.94(23.8)
1/2	8	3/4-16	FEM-FT8-OST12-	1.95(49.5)	0.47(11.9)	0.37(9.4)	1.13(28.6)



## Переходник с наружной резьбой

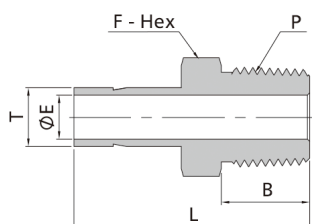

25 мм и меньше

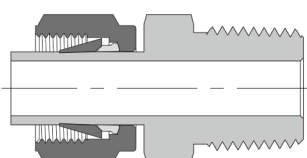

28 мм и более

Размер E наименьший номинальный размер.

### Метрическая трубка

### Резьба NPT

Т-Трубка (мм)	Р-NPT Резьба	Артикул	Размеры, мм. (дюйм.)			
			L	B	E	F
3	1/8	FEM-MT3-NPT2-	29.4(1.16)	9.7(0.38)	1.8(0.07)	12.0(0.47)
4	1/8	FEM-MT4-NPT2-	29.4(1.16)	9.7(0.38)	2.4(0.09)	12.0(0.47)
6	1/8	FEM-MT6-NPT2-	32.8(1.29)	9.7(0.38)	4.1(0.16)	12.0(0.47)
6	1/4	FEM-MT6-NPT4-	38.1(1.50)	14.2(0.56)	4.1(0.16)	14.0(0.55)
6	3/8	FEM-MT6-NPT6-	39.2(1.54)	14.2(0.56)	4.1(0.16)	18.0(0.71)
6	1/2	FEM-MT6-NPT8-	42.1(1.66)	19.1(0.75)	4.1(0.16)	22.0(0.87)
8	1/4	FEM-MT8-NPT4-	39.1(1.54)	14.2(0.56)	5.6(0.22)	14.0(0.55)
8	3/8	FEM-MT8-NPT6-	39.9(1.57)	14.2(0.56)	5.6(0.22)	19.0(0.75)
10	1/4	FEM-MT10-NPT4-	39.9(1.57)	14.2(0.56)	7.1(0.28)	14.0(0.55)
10	3/8	FEM-MT10-NPT6-	40.6(1.60)	14.2(0.56)	7.1(0.28)	18.0(0.71)
10	1/2	FEM-MT10-NPT8-	46.2(1.82)	19.1(0.75)	7.1(0.28)	22.0(0.87)
12	1/4	FEM-MT12-NPT4-	46.5(1.83)	14.2(0.56)	7.1(0.28)	14.0(0.55)
12	3/8	FEM-MT12-NPT6-	46.2(1.82)	14.2(0.56)	8.8(0.35)	18.0(0.71)
12	1/2	FEM-MT12-NPT8-	52.1(2.05)	19.1(0.75)	8.8(0.35)	22.0(0.87)
16	1/2	FEM-MT16-NPT8-	50.8(2.00)	19.1(0.75)	11.9(0.47)	22.0(0.87)
16	3/4	FEM-MT16-NPT12-	51.6(2.03)	19.1(0.75)	12.0(0.47)	27.0(1.06)
18	1/2	FEM-MT18-NPT8-	50.8(2.00)	19.1(0.75)	11.9(0.47)	27.0(1.06)
18	3/4	FEM-MT18-NPT12-	51.6(2.03)	19.1(0.75)	14.0(0.55)	27.0(1.06)
20	1/2	FEM-MT20-NPT8-	53.3(2.1)	19.1(0.75)	11.9(0.47)	22.0(0.87)
20	3/4	FEM-MT20-NPT12-	53.8(2.12)	19.1(0.75)	15.5(0.61)	27.0(1.06)
25	1	FEM-MT25-NPT16-	65.9(2.59)	23.9(0.94)	19.8(0.78)	35.0(1.38)
28	1	FEM-MT28-NPT16-	74.7(2.94)	23.9(0.94)	22.2(0.87)	35.0(1.38)
28	1 1/4	FEM-MT28-NPT20-	76.2(3.00)	23.9(0.94)	22.5(0.89)	46.0(1.81)
30	1	FEM-MT30-NPT16-	79.2(3.12)	23.9(0.94)	22.2(0.87)	41.0(1.61)
30	1 1/4	FEM-MT30-NPT20-	80.0(3.15)	23.9(0.94)	24.3(0.96)	46.0(1.81)
32	1 1/4	FEM-MT32-NPT20-	81.0(3.19)	23.9(0.94)	26.5(1.04)	46.0(1.81)
38	1 1/2	FEM-MT38-NPT24-	92.2(3.63)	26.2(1.03)	31.6(1.24)	55.0(2.17)

### Метрическая резьба

### Коническая резьба ISO (RT)

Т-Трубка (мм)	Р-RT Резьба	Артикул	Размеры, мм. (дюйм.)			
			L	B	E	F
3	1/8	FEM-MT3-RT2-	29.4(1.16)	9.7(0.38)	2.4(0.09)	12.0(0.47)
4	1/8	FEM-MT4-RT2-	29.4(1.16)	9.7(0.38)	2.0(0.08)	12.0(0.47)
6	1/8	FEM-MT6-RT2-	32.8(1.29)	9.7(0.38)	4.1(0.16)	12.0(0.47)
6	1/4	FEM-MT6-RT 4-	38.1(1.50)	14.2(0.56)	4.1(0.16)	14.0(0.55)
8	1/4	FEM-MT8-RT4-	39.1(1.54)	14.2(0.56)	5.6(0.22)	14.0(0.55)
8	3/8	FEM-MT8-RT6-	39.9(1.57)	14.2(0.56)	5.6(0.22)	18.0(0.71)
10	1/4	FEM-MT10-RT4-	39.9(1.57)	14.2(0.56)	7.1(0.28)	14.0(0.55)
10	3/8	FEM-MT10-RT6-	40.6(1.60)	14.2(0.56)	7.1(0.28)	18.0(0.71)
10	1/2	FEM-MT10-RT8-	44.5(1.75)	19.1(0.75)	7.1(0.28)	22.0(0.87)
12	1/4	FEM-MT12-RT4-	46.5(1.83)	14.2(0.56)	7.1(0.28)	16.0(0.63)
12	3/8	FEM-MT12-RT6-	46.2(1.82)	14.2(0.56)	8.8(0.35)	18.0(0.71)
12	1/2	FEM-MT12-RT8-	51.8(2.04)	19.1(0.75)	8.8(0.35)	22.0(0.87)
16	1/2	FEM-MT16-RT8-	50.8(2.00)	19.1(0.75)	11.9(0.47)	22.0(0.87)
18	3/4	FEM-MT18-RT12-	51.6(2.03)	19.1(0.75)	14.0(0.55)	27.0(1.06)
20	3/4	FEM-MT20-RT12-	52.4(2.06)	19.1(0.75)	15.5(0.61)	27.0(1.06)
25	1	FEM-MT25-RT16-	65.9(2.59)	23.9(0.94)	19.8(0.78)	35.0(1.38)
28	1	FEM-MT28-RT16-	74.7(2.94)	23.9(0.94)	22.2(0.87)	35.0(1.38)
28	1/4	FEM-MT28-RT20-	76.2(3.00)	23.9(0.94)	22.5(0.89)	46.0(1.81)
30	1/4	FEM-MT30-RT20-	80.0(3.15)	23.9(0.94)	24.3(0.96)	46.0(1.81)
32	1 1/4	FEM-MT32-RT20-	81.0(3.19)	23.9(0.94)	26.5(1.04)	46.0(1.81)
38	1 1/2	FEM-MT38-RT24-	92.2(3.63)	26.2(1.03)	31.6(1.24)	55.0(2.17)

# Размеры

## Переходник с наружной резьбой

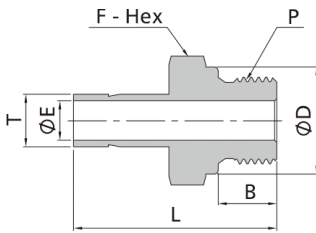

25 мм и менее

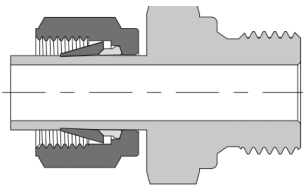

28мм и более

Размер E наименьший номинальный размер.

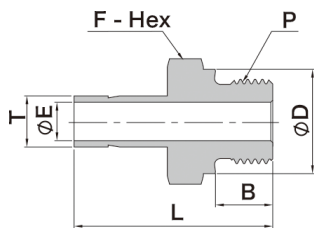

25 мм и менее

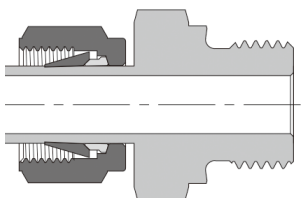

28 мм и более

Размер E наименьший номинальный размер.

### Метрическая резьба

### Цилиндрическая резьба ISO (RS)

Т-Трубка (мм)	P-RS Резьба	Артикул	Dimensions, mm (in.)				
			L	B	E	F	D
3	1/8	FEM-MT3-RS2-	31.0(1.22)	7.1(0.28)	1.8(0.07)	14.0(0.55)	13.7(0.54)
4	1/8	FEM-MT4-RS2-	31.8(1.25)	7.1(0.28)	2.4(0.09)	14.0(0.55)	13.7(0.54)
6	1/8	FEM-MT6-RS2-	34.3(1.35)	7.1(0.28)	4.0(0.16)	14.0(0.55)	13.7(0.54)
6	1/4	FEM-MT6-RS4-	39.1(1.54)	11.2(0.44)	4.1(0.16)	19.0(0.75)	17.8(0.70)
8	1/4	FEM-MT8-RS4-	39.6(1.56)	11.2(0.44)	5.6(0.22)	19.0(0.75)	17.8(0.70)
10	1/4	FEM-MT10-RS4-	40.9(1.61)	11.2(0.44)	5.9(0.23)	19.0(0.75)	17.8(0.70)
10	3/8	FEM-MT10-RS6-	41.7(1.64)	11.2(0.44)	7.1(0.28)	22.0(0.87)	21.6(0.85)
10	1/2	FEM-MT10-RS8-	44.7(1.76)	14.2(0.56)	7.1(0.28)	27.0(1.06)	25.9(1.02)
12	1/4	FEM-MT12-RS4-	46.7(1.84)	11.2(0.44)	5.9(0.23)	19.0(0.75)	17.8(0.70)
12	3/8	FEM-MT12-RS6-	47.2(1.86)	11.2(0.44)	7.9(0.31)	22.0(0.87)	21.6(0.85)
12	1/2	FEM-MT12-RS8-	50.5(1.99)	14.2(0.56)	8.8(0.35)	27.0(1.06)	25.9(1.02)
16	1/2	FEM-MT16-RS8-	50.8(2.00)	14.2(0.56)	11.9(0.47)	27.0(1.06)	25.9(1.02)
18	3/4	FEM-MT18-RS12-	55.9(2.20)	16.0(0.63)	13.9(0.55)	35.0(1.38)	32.0(1.26)
20	3/4	FEM-MT20-RS12-	57.0(2.24)	16.0(0.63)	15.5(0.61)	35.0(1.38)	32.0(1.26)
25	1	FEM-MT25-RS16-	65.1(2.56)	18.3(0.72)	19.8(0.78)	41.0(1.61)	38.9(1.53)
28	1	FEM-MT28-RS16-	71.9(2.83)	18.3(0.72)	19.8(0.78)	41.0(1.61)	38.9(1.53)
28	1 1/4	FEM-MT28-RS20-	77.0(3.03)	19.8(0.78)	22.5(0.89)	50.0(1.97)	49.0(1.93)
30	1 1/4	FEM-MT30-RS20-	80.8(3.18)	19.8(0.78)	24.3(0.96)	50.0(1.97)	49.0(1.93)
32	1 1/4	FEM-MT32-RS20-	81.8(3.22)	19.8(0.78)	26.5(1.04)	50.0(1.97)	49.0(1.93)
38	1 1/2	FEM-MT38-RS24-	94.5(3.72)	20.6(0.81)	31.6(1.24)	55.0(2.17)	54.7(2.15)

### Метрическая трубка

### Цилиндрическая резьба ISO (RP)

Т-Трубка (мм)	P-RP Резьба	Артикул	Размеры, мм (дюйм.)				
			L	B	E	F	D
3	1/8	FEM-MT3-RP2-	31.0(1.22)	7.1(0.28)	1.8(0.07)	14.0(0.55)	13.7(0.54)
4	1/8	FEM-MT4-RP2-	31.8(1.25)	7.1(0.28)	2.0(0.08)	14.0(0.55)	13.7(0.54)
6	1/8	FEM-MT6-RP2-	34.3(1.35)	7.1(0.28)	4.0(0.16)	14.0(0.55)	13.7(0.54)
6	1/4	FEM-MT6-RP4-	38.1(1.50)	11.2(0.44)	4.0(0.16)	19.0(0.75)	17.8(0.70)
8	1/4	FEM-MT8-RP4-	38.9(1.53)	11.2(0.44)	5.6(0.22)	19.0(0.75)	17.8(0.70)
10	1/4	FEM-MT10-RP4-	38.9(1.53)	11.2(0.44)	6.4(0.25)	19.0(0.75)	17.8(0.70)
10	3/8	FEM-MT10-RP6-	39.7(1.56)	11.2(0.44)	7.1(0.28)	22.0(0.87)	21.6(0.85)
10	1/2	FEM-MT10-RP8-	42.9(1.69)	14.2(0.56)	7.1(0.28)	27.0(1.06)	25.9(1.02)
12	1/4	FEM-MT12-RP4-	43.7(1.72)	11.2(0.44)	6.4(0.25)	19.0(0.75)	17.8(0.70)
12	3/8	FEM-MT12-RP6-	44.5(1.75)	11.2(0.44)	7.9(0.31)	22.0(0.87)	21.6(0.85)
12	1/2	FEM-MT12-RP8-	49.2(1.94)	14.2(0.56)	9.1(0.36)	27.0(1.06)	25.9(1.02)
16	1/2	FEM-MT16-RP8-	50.8(2.00)	14.2(0.56)	11.9(0.47)	27.0(1.06)	25.9(1.02)
18	3/4	FEM-MT18-RP12-	53.2(2.09)	16.0(0.63)	14.0(0.55)	33.0(1.30)	32.0(1.26)
20	3/4	FEM-MT20-RP12-	54.0(2.13)	16.0(0.63)	15.5(0.61)	33.0(1.30)	32.0(1.26)
25	1	FEM-MT25-RP16-	65.1(2.56)	18.3(0.72)	19.8(0.78)	41.0(1.61)	38.9(1.53)
28	1	FEM-MT28-RP16-	72.7(2.86)	18.3(0.72)	19.8(0.78)	41.0(1.61)	38.9(1.53)
28	1 1/4	FEM-MT28-RP20-	77.3(3.04)	19.8(0.78)	22.5(0.89)	50.0(1.97)	49.0(1.93)
30	1 1/4	FEM-MT30-RP20-	80.8(3.18)	19.8(0.78)	24.3(0.96)	50.0(1.97)	49.0(1.93)
32	1 1/4	FEM-MT32-RP20-	82.1(3.23)	19.8(0.78)	26.5(1.04)	50.0(1.97)	49.0(1.93)
38	1 1/2	FEM-MT38-RP24-	94.5(3.72)	20.6(0.81)	31.6(1.24)	55.0(2.17)	54.7(2.15)

## Переходник с внутренней резьбой

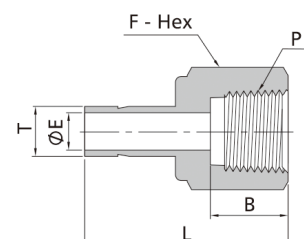

1" и менее

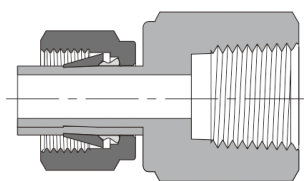

1 1/4" и более

## Дюймовая трубка Резьба NPT

Т-Трубка (дюйм.)	Р-NPT резьба	Артикул	Размеры, дюйм. (мм)			
			L	B	E	F
1/16	1/8	FEW-FT1-NPT2-	1.07(27.2)	0.41(10.4)	0.03(0.8)	0.56(14.3)
1/8	1/8	FEW-FT2-NPT2-	1.24(31.5)	0.41(10.4)	0.08(2.0)	0.56(14.3)
1/8	1/4	FEW-FT2-NPT4-	1.39(35.3)	0.59(15.0)	0.08(2.0)	0.75(19.1)
3/16	1/8	FEW-FT3-NPT2-	1.25(31.8)	0.41(10.4)	0.11(2.9)	0.56(14.3)
3/16	1/4	FEW-FT3-NPT4-	1.41(35.8)	0.59(15.0)	0.12(3.0)	0.75(19.1)
1/4	1/8	FEW-FT4-NPT2-	1.30(33.0)	0.41(10.4)	0.17(4.3)	0.56(14.3)
1/4	1/4	FEW-FT4-NPT4-	1.46(37.1)	0.59(15.0)	0.17(4.3)	0.75(19.1)
1/4	3/8	FEW-FT4-NPT6-	1.55(39.4)	0.59(15.0)	0.17(4.3)	0.87(22.2)
1/4	1/2	FEW-FT4-NPT6-	1.79(45.5)	0.78(19.8)	0.17(4.3)	1.06(27.0)
5/16	1/8	FEW-FT5-NPT2-	1.34(34.0)	0.41(10.4)	0.22(5.6)	0.56(14.3)
5/16	1/4	FEW-FT5-NPT4-	1.48(37.6)	0.59(15.0)	0.22(5.6)	0.75(19.1)
5/16	3/8	FEW-FT5-NPT6-	1.59(40.4)	0.59(15.0)	0.22(5.6)	0.87(22.2)
3/8	1/8	FEW-FT6-NPT2-	1.35(34.3)	0.41(10.4)	0.27(6.9)	0.56(14.3)
3/8	1/4	FEW-FT6-NPT4-	1.50(38.1)	0.59(15.0)	0.27(6.9)	0.75(19.1)
3/8	3/8	FEW-FT6-NPT6-	1.59(40.4)	0.59(15.0)	0.27(6.9)	0.87(22.2)
3/8	1/2	FEW-FT6-NPT8-	1.84(46.7)	0.78(19.8)	0.27(6.9)	1.06(27.0)
1/2	1/4	FEW-FT8-NPT4-	1.71(43.4)	0.59(15.0)	0.37(9.4)	0.75(19.1)
1/2	3/8	FEW-FT8-NPT6-	1.79(45.5)	0.59(15.0)	0.37(9.4)	0.87(22.2)
1/2	1/2	FEW-FT8-NPT8-	2.04(51.8)	0.78(19.8)	0.37(9.4)	1.06(27.0)
5/8	3/8	FEW-FT10-NPT6-	1.86(47.2)	0.59(15.0)	0.47(11.9)	0.87(22.2)
5/8	1/2	FEW-FT10-NPT8-	2.09(53.1)	0.78(19.8)	0.47(11.9)	1.06(27.0)
3/4	1/2	FEW-FT12-NPT8-	2.08(52.8)	0.78(19.8)	0.58(14.7)	1.06(27.0)
3/4	3/4	FEW-FT12-NPT12-	2.16(54.9)	0.81(20.6)	0.58(14.7)	1.31(33.3)
3/4	1	FEW-FT12-NPT16-	2.30(58.4)	1.00(25.4)	0.58(14.7)	1.63(41.3)
7/8	3/4	FEW-FT14-NPT12-	2.22(56.4)	0.81(20.6)	0.58(14.7)	1.31(33.3)
1	3/4	FEW-FT16-NPT12-	2.39(60.7)	0.81(20.6)	0.80(20.3)	1.31(33.3)
1	1	FEW-FT16-NPT16-	2.53(64.3)	1.00(25.4)	0.80(20.3)	1.63(41.3)
1 1/4	1 1/4	FEW-FT20-NPT20-	3.06(77.7)	1.00(25.4)	1.02(25.9)	2.13(54.0)
1 1/2	1 1/2	FEW-FT24-NPT24-	3.50(88.9)	1.09(27.7)	1.25(31.8)	2.37(60.3)

## Дюймовая трубка Коническая резьба ISO (RT)

Т-Трубка (in.)	Р-RT Резьба	Артикул	Размеры, дюйм. (мм)			
			L	B	E	F
1/4	1/8	FEW-FT4-RT2-	1.30(33.0)	0.41(10.4)	0.17(4.3)	0.56(14.3)
1/4	1/4	FEW-FT4-RT4-	1.45(36.8)	0.59(15.0)	0.17(4.3)	0.75(19.1)
3/8	1/4	FEW-FT6-RT4-	1.50(38.1)	0.59(15.0)	0.27(6.9)	0.75(19.1)
3/8	3/8	FEW-FT6-RT6-	1.59(40.4)	0.59(15.0)	0.27(6.9)	0.87(22.2)
1/2	1/4	FEW-FT8-RT4-	1.71(43.4)	0.59(15.0)	0.37(9.4)	0.75(19.1)
1/2	3/8	FEW-FT8-RT6-	1.80(45.7)	0.59(15.0)	0.37(9.4)	0.87(22.2)
1/2	1/2	FEW-FT8-RT8-	2.05(52.1)	0.78(19.8)	0.37(9.4)	1.06(27.0)

## Переходник с внутренней резьбой

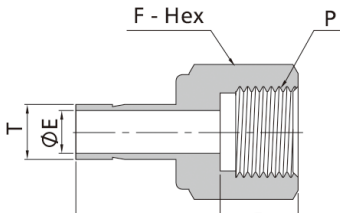

Дюймовая трубка			Цилиндрическая резьба ISO (RP)			
Т-Трубка (дюйм.)	P-RP Резьба	Артикул	Размеры, дюйм. (мм)			
			L	B	E	F
1/8	1/8	FEW-FT2-RP2-	1.17(29.7)	0.40(10.2)	0.08(2.0)	0.56(14.3)
1/4	1/8	FEW-FT4-RP2-	1.25(31.8)	0.40(10.2)	0.17(4.3)	0.56(14.3)
1/4	1/4	FEW-FT4-RP4-	1.50(38.1)	0.61(15.5)	0.17(4.3)	0.75(19.1)
3/8	1/4	FEW-FT6-RP4-	1.55(39.4)	0.61(15.5)	0.27(6.9)	0.75(19.1)
3/8	3/8	FEW-FT6-RP6-	1.57(39.9)	0.60(15.2)	0.27(6.9)	0.94(23.8)
1/2	3/8	FEW-FT8-RP6-	1.78(45.2)	0.60(15.2)	0.38(9.7)	0.94(23.8)
1/2	1/2	FEW-FT8-RP8-	1.95(49.5)	0.73(18.5)	0.38(9.7)	1.06(27.0)

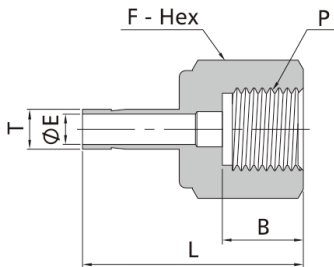

Дюймовая трубка			Цилиндрическая резьба ISO (RG)			
Т-Трубка (дюйм.)	P-RG Резьба	Артикул	Размеры, дюйм. (мм)			
			L	B	E	F
1/4	1/4	FEW-FT4-RG4-	1.39(35.3)	0.51(12.9)	0.17(4.3)	0.75(19.1)
3/8	3/8	FEW-FT6-RG6-	1.55(39.4)	0.56(14.2)	0.26(6.6)	0.94(23.8)
1/2	1/2	FEW-FT8-RG8-	1.80(45.7)	0.74(18.8)	0.28(7.1)	1.06(27.0)

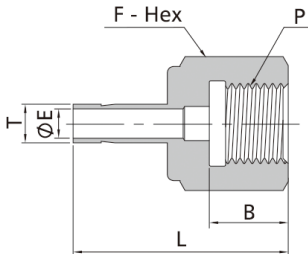

Дюймовая трубка			ISO Цилиндрическая резьба (RJ)			
Т-Трубка (дюйм.)	P-RG Резьба	Артикул	Размеры, дюйм. (мм)			
			L	B	E	F
1/4	1/4	FEW-FT4-RJ4-	1.39(35.3)	0.51(12.9)	0.17(4.3)	0.75(19.1)
3/8	3/8	FEW-FT6-RJ6-	1.55(39.4)	0.62(15.8)	0.26(6.6)	0.94(23.8)
1/2	1/2	FEW-FT8-RJ8-	1.94(49.3)	0.74(18.8)	0.28(7.1)	1.06(27.0)

Адаптировано к японскому стандарту B7505]

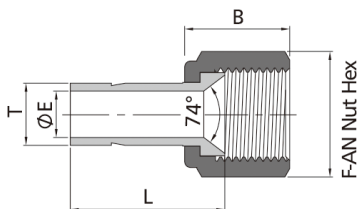

Дюймовая трубка			Уплотнительный конус 37° (AN)			
Т-Трубка (дюйм.)	AN Резьба (дюйм.)	Артикул	Размеры, дюйм. (мм)			
			L	B	E	F
1/8	1/8	FEW-FT2-AN2-	0.88(22.4)	0.55(14.0)	0.08(2.0)	0.37(9.5)
1/8	1/4	FEW-FT2-AN4-	0.88(22.4)	0.62(15.8)	0.16(4.0)	0.56(14.3)
1/4	1/4	FEW-FT4-AN4-	0.96(24.4)	0.62(15.8)	0.18(4.6)	0.56(14.3)
3/8	3/8	FEW-FT6-AN6-	0.98(24.9)	0.73(18.5)	0.27(6.8)	0.75(19.05)
1/2	1/2	FEW-FT8-AN8-	1.42(36.1)	0.85(21.6)	0.37(9.4)	0.87(22.2)
3/4	3/4	FEW-FT12-AN12-	1.49(37.8)	1.03(26.2)	0.58(14.7)	1.25(31.8)

## Переходник с внутренней резьбой

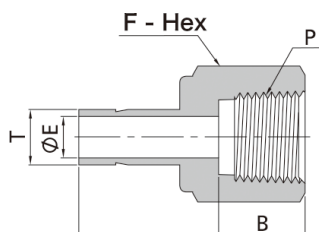

Метрическая трубка			Резьба NPT			
Т-Трубка (мм)	Р-NPT Резьба	Артикул	Размеры, мм (дюйм.)			
			L	B	E	F
3	1/8	FEW-MT3-NPT2-	28.8(1.13)	10.4(0.41)	1.3(0.05)	14.0(0.55)
4	1/8	FEW-MT4-NPT2-	33.3(1.31)	10.4(0.41)	2.4(0.09)	14.0(0.55)
6	1/8	FEW-MT6-NPT2-	32.5(1.28)	10.4(0.41)	4.1(0.16)	14.0(0.55)
6	1/4	FEW-MT6-NPT4-	37.1(1.46)	15.0(0.59)	4.1(0.16)	19.0(0.75)
8	1/8	FEW-MT8-NPT2-	35.1(1.38)	10.4(0.41)	5.6(0.22)	14.0(0.55)
8	1/4	FEW-MT8-NPT4-	37.6(1.48)	15.0(0.59)	5.6(0.22)	19.0(0.75)
8	3/8	FEW-MT8-NPT6-	36.5(1.44)	15.0(0.59)	5.6(0.22)	22.0(0.87)
10	1/4	FEW-MT10-NPT4-	38.1(1.50)	15.0(0.59)	7.1(0.28)	19.0(0.75)
10	3/8	FEW-MT10-NPT6-	40.1(1.58)	15.0(0.59)	7.1(0.28)	22.0(0.87)
10	1/2	FEW-MT10-NPT8-	46.5(1.83)	19.8(0.78)	7.1(0.28)	27.0(1.06)
12	1/4	FEW-MT12-NPT4-	43.7(1.72)	15.0(0.59)	8.8(0.35)	19.0(0.75)
12	3/8	FEW-MT12-NPT6-	42.9(1.69)	15.0(0.59)	8.8(0.35)	22.0(0.87)
12	1/2	FEW-MT12-NPT8-	52.3(2.06)	19.8(0.78)	8.8(0.35)	27.0(1.06)
16	1/2	FEW-MT16-NPT8-	49.2(1.94)	19.8(0.78)	12.0(0.47)	27.0(1.06)
18	3/4	FEW-MT18-NPT12-	52.4(2.06)	20.6(0.81)	14.0(0.55)	32.0(1.26)
20	1/2	FEW-MT20-NPT8-	50.0(1.97)	19.8(0.78)	15.5(0.61)	27.0(1.06)
20	3/4	FEW-MT20-NPT12-	57.2(2.25)	20.6(0.81)	15.5(0.61)	35.0(1.38)
25	1	FEW-MT25-NPT16-	66.7(2.63)	25.4(1.00)	19.8(0.78)	41.0(1.61)

Метрическая трубка			Коническая резьба ISO (RT)			
Т-Трубка (мм)	Р-NPT Резьба	Артикул	Размеры, мм (дюйм.)			
			L	B	E	F
3	1/8	FEW-MT3-RT2-	28.8(1.13)	10.4(0.41)	1.8(0.07)	14.0(0.55)
4	1/8	FEW-MT4-RT2-	28.6(1.13)	10.4(0.41)	2.4(0.09)	14.0(0.55)
6	1/8	FEW-MT6-RT2-	33.0(1.30)	10.4(0.41)	4.1(0.16)	14.0(0.55)
8	1/4	FEW-MT8-RT4-	37.6(1.48)	15.0(0.59)	5.6(0.22)	19.0(0.75)
10	1/4	FEW-MT10-RT4-	38.1(1.50)	15.0(0.59)	7.1(0.28)	19.0(0.75)
10	3/8	FEW-MT10-RT6-	36.5(1.44)	15.0(0.59)	7.1(0.28)	22.0(0.87)
10	1/2	FEW-MT10-RT8-	41.3(1.63)	19.8(0.78)	7.1(0.28)	27.0(1.06)
12	1/4	FEW-MT12-RT4-	43.7(1.72)	15.0(0.59)	8.8(0.35)	19.0(0.75)
12	3/8	FEW-MT12-RT6-	43.7(1.72)	15.0(0.59)	8.8(0.35)	22.0(0.87)
12	1/2	FEW-MT12-RT8-	46.8(1.84)	19.8(0.78)	8.8(0.35)	27.0(1.06)
16	1/2	FEW-MT16-RT8-	48.4(1.91)	19.8(0.78)	12.0(0.47)	27.0(1.06)
18	3/4	FEW-MT18-RT12-	52.4(2.06)	20.6(0.81)	14.0(0.55)	32.0(1.26)
20	3/4	FEW-MT20-RT12-	52.4(2.06)	20.6(0.81)	15.5(0.61)	32.0(1.26)
25	1	FEW-MT25-RT16-	66.7(2.63)	25.4(1.00)	19.8(0.78)	41.0(1.61)

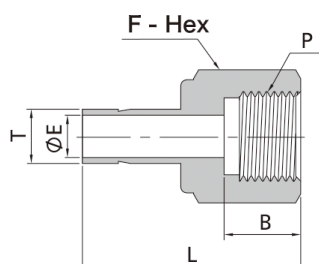

Метрическая трубка			Цилиндрическая резьба ISO (RP)			
Т-Трубка (мм)	Р-RP Резьба	Артикул	Размеры, мм (дюйм.)			
			L	B	E	F
6	1/8	FEW-MT6-RP2-	32.0(1.26)	10.2(0.40)	4.1(0.16)	14.0(0.55)
6	1/4	FEW-MT6-RP4-	37.8(1.49)	15.2(0.60)	4.1(0.16)	19.0(0.75)
12	1/2	FEW-MT12-RP8-	49.8(1.96)	18.8(0.74)	8.8(0.35)	27.0(1.06)

# Размеры

## Переходник с внутренней резьбой

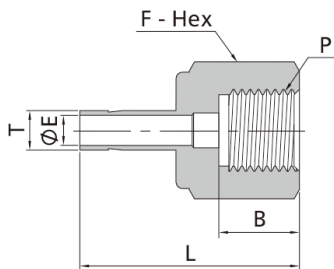

Метрическая трубка			Цилиндрическая резьба ISO (RG)			
Т-Трубка (мм)	P-RG Резьба	Артикул	Размеры, мм (дюйм.)			
			L	B	E	F
3	1/8	FEW-MT3-RG2-	28.6(1.13)	9.8(0.39)	1.9(0.07)	14.0(0.55)
3	1/4	FEW-MT3-RG4-	33.5(1.32)	12.9(0.50)	1.9(0.07)	19.0(0.75)
4	1/8	FEW-MT4-RG2-	29.4(1.16)	9.8(0.39)	2.4(0.09)	14.0(0.55)
6	1/8	FEW-MT6-RG2-	29.1(1.15)	9.8(0.39)	4.1(0.16)	14.0(0.55)
6	1/4	FEW-MT6-RG4-	35.3(1.39)	12.9(0.50)	4.1(0.16)	19.0(0.75)
6	3/8	FEW-MT6-RG6-	38.4(1.51)	14.2(0.56)	4.1(0.16)	24.0(0.94)
6	1/2	FEW-MT6-RG8-	42.9(1.69)	18.8(0.74)	4.1(0.16)	27.0(1.06)
8	1/4	FEW-MT8-RG4-	33.0(1.30)	12.9(0.50)	5.5(0.22)	19.0(0.75)
8	3/8	FEW-MT8-RG6-	38.9(1.53)	14.2(0.56)	5.6(0.22)	24.0(0.94)
8	1/2	FEW-MT8-RG8-	43.7(1.72)	18.8(0.74)	5.6(0.22)	27.0(1.06)
10	1/4	FEW-MT10-RG4-	34.5(1.36)	12.9(0.50)	5.5(0.22)	19.0(0.75)
10	3/8	FEW-MT10-RG6-	36.1(1.42)	14.2(0.56)	6.5(0.26)	24.0(0.94)
10	1/2	FEW-MT10-RG8-	41.1(1.62)	18.8(0.74)	7.1(0.28)	27.0(1.06)
12	1/4	FEW-MT12-RG4-	40.1(1.58)	12.9(0.50)	5.5(0.22)	19.0(0.75)
12	3/8	FEW-MT12-RG6-	44.7(1.76)	14.2(0.56)	6.5(0.26)	24.0(0.94)
12	1/2	FEW-MT12-RG8-	48.8(1.92)	18.8(0.74)	7.0(0.28)	27.0(1.06)
16	1/2	FEW-MT16-RG8-	49.0(1.93)	18.8(0.74)	7.0(0.28)	27.0(1.06)
18	1/2	FEW-MT18-RG8-	49.3(1.94)	18.8(0.74)	7.0(0.28)	27.0(1.06)

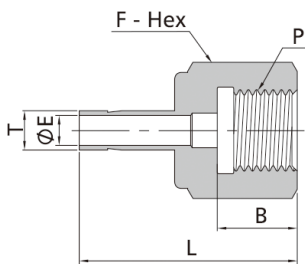

Адаптировано к японскому стандарту

Metric Tube			Цилиндрическая резьба ISO (RJ)			
Т-Трубка (мм)	P-RJ Резьба	Артикул	Размеры, мм (дюйм.)			
			L	B	E	F
6	1/4	FEW-MT6-RJ4-	35.3(1.39)	12.9(0.50)	4.1(0.16)	19.0(0.75)
6	3/8	FEW-MT6-RJ6-	38.6(1.52)	15.8(0.62)	4.1(0.16)	24.0(0.94)
6	1/2	FEW-MT6-RJ8-	42.9(1.69)	18.8(0.74)	4.1(0.16)	27.0(1.06)
8	1/4	FEW-MTS-RJ4-	33.0(1.30)	12.9(0.50)	5.5(0.22)	19.0(0.75)
8	3/8	FEW-MTS-RJ6-	39.4(1.55)	15.8(0.62)	5.6(0.22)	24.0(0.94)
8	1/2	FEW-MTS-RJ8-	43.7(1.72)	18.8(0.74)	5.6(0.22)	27.0(1.06)
10	1/4	FEW-MT10-RJ4-	34.5(1.36)	12.9(0.50)	5.5(0.22)	19.0(0.75)
10	3/8	FEW-MT10-RJ6-	36.1(1.42)	15.8(0.62)	6.5(0.26)	24.0(0.94)
10	1/2	FEW-MT10-RJ8-	41.1(1.62)	18.8(0.74)	7.1(0.28)	27.0(1.06)
12	1/4	FEW-MT12-RJ4-	40.1(1.58)	12.9(0.50)	5.5(0.22)	19.0(0.75)
12	3/8	FEW-MT12-RJ6-	44.7(1.76)	15.8(0.62)	6.5(0.26)	24.0(0.94)
12	1/2	FEW-MT12-RJ8-	48.8(1.92)	18.8(0.74)	7.0(0.28)	27.0(1.06)

## Адаптер приварной

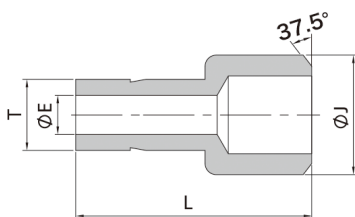

Дюймовая трубка			Приварка встык		
Т-Трубка (дюйм.)	Стыковая приварка Размер	Артикул	Dimensions, in. (mm)		
			L	J	E
1/4	1/4	FLG-FT4-PB4-	1.14(29.0)	0.54(13.7)	0.17(4.3)
3/8	1/2	FLG-FT6-PB8-	1.46(37.1)	0.84(21.3)	0.27(6.9)
1/2	1/2	FLG-FT8-PB8-	1.66(42.2)	0.84(21.3)	0.37(9.4)
1/2	3/4	FLG-FT8-PB12-	1.68(42.7)	1.05(26.7)	0.37(9.4)
3/4	3/4	FLG-FT12-PB12-	1.87(47.5)	1.05(26.7)	0.58(14.7)

## Адаптер фланцевый

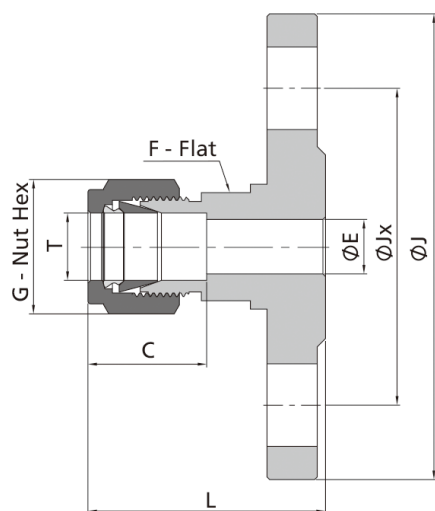

- ✓ Цельнокованный корпус
- ✓ Фланцы ASME соответствуют ASME B16.5.
- ✓ Фланцы DIN соответствуют DIN 2501/2526.
- ✓ Фланцы GB соответствуют GB/T 9123.1.
- ✓ Фланцы EN соответствуют EN 1092-1.
- ✓ Фланцы JIS соответствуют JIS B 2220.

### Фланец ASME

Т-Трубка (дюйм.)	ASME Фланец NPS	Класс	Артикул	Размеры, дюйм (мм.)						
				L	J	Jx	E	C	G	F
1/2	1/2	150	FL-YZ4-F8-150-	1.61(40.9)	3.50(88.9)	2.38(60.5)	0.19(4.8)	0.60(15.2)	0.56(14.3)	0.81(20.6)
1/2	1/2	150	FL-YZ6-F8-300-	1.79(45.5)	3.75(95.3)	2.62(66.5)	0.28(7.1)	0.66(16.8)	0.69(17.5)	0.81(20.6)
1/2	1/2	150	FL-YZ8-F8-150-	1.78(45.2)	3.50(88.9)	2.38(60.5)	0.41(10.4)	0.90(22.9)	0.87(22.2)	0.81(20.6)
3/8	1	300	FL-YZ8-F16-150-	1.90(48.3)	4.25(108.0)	3.12(79.2)	0.41(10.4)	0.90(22.9)	0.87(22.2)	0.81(20.6)
1/4	2	150	FL-YZ8-F32-150-	2.09(53.1)	6.00(152.4)	4.76(121.0)	0.41(10.4)	0.90(22.9)	0.87(22.2)	0.81(20.6)
3/4	1	150	FL-YZ12-F16-150-	1.98(50.3)	4.25(108.0)	3.12(79.2)	0.62(15.7)	0.96(24.4)	1.13(28.6)	1.25(31.8)
1	1	150	FL-YZ16-F16-150-	2.38(60.5)	4.25(108.0)	3.12(79.2)	0.88(22.4)	1.23(31.2)	1.50(38.1)	1.37(34.9)

### Фланец DIN/GB , Класс давления PN 40

Т-Трубка (мм.)	DIN Размер фланца	Артикул	Размеры, мм (дюйм.)						
			L	J	Jx	E	C	G	F
6	25	FL-GZ6-F25-40B1-	47.5(1.87)	115.0(4.53)	85.0(3.35)	4.8(0.19)	15.3(0.60)	14.0(0.55)	20.0(0.79)
12	15	FL-GZ12-F15-40B1-	48.5(1.91)	95.0(3.74)	65.0(2.56)	9.5(0.37)	22.8(0.90)	22.0(0.87)	20.0(0.79)
12	25	FL-GZ12-F25-40B1-	50.5(1.99)	115.0(4.53)	85.0(3.35)	9.5(0.37)	22.8(0.90)	22.0(0.87)	20.0(0.79)
12	50	FL-GZ12-F50-40B1-	55.3(2.18)	165.0(6.50)	125.0(4.92)	9.5(0.37)	22.8(0.90)	22.0(0.87)	20.0(0.79)
18	15	FL-GZ18-F15-40B1-	51.8(2.04)	95.0(3.74)	65.0(2.56)	15.1(0.59)	24.4(0.96)	30.0(1.18)	32.0(1.26)
18	25	FL-GZ18-F25-40B1-	53.8(2.12)	115.0(4.53)	85.0(3.35)	15.1(0.59)	24.4(0.96)	30.0(1.18)	32.0(1.26)
25	25	FL-GZ25-F25-40B1-	64.0(2.52)	115.0(4.53)	85.0(3.35)	21.8(0.86)	31.3(1.23)	38.0(1.50)	35.0(1.38)

## Адаптер фланцевый

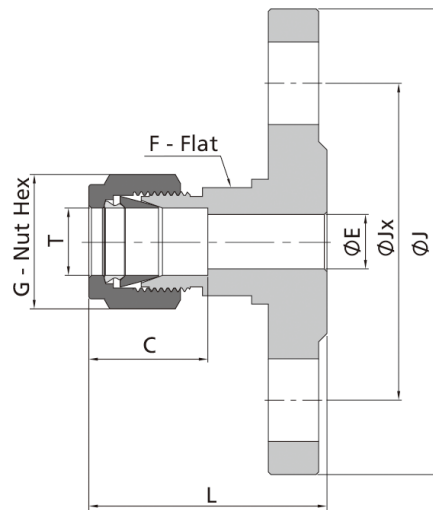

- ✓ Цельнокованный корпус
- ✓ Фланцы ASME соответствуют ASME B16.5.
- ✓ Фланцы DIN соответствуют DIN 2501/2526.
- ✓ Фланцы GB соответствуют GB/T 9123.1.
- ✓ Фланцы EN соответствуют EN 1092-1.
- ✓ Фланцы JIS соответствуют JIS B 2220.

### Фланец EN, Класс давления PN 40

Т-Трубка (мм.)	EN Размер фланца DN	Артикул	Размеры, мм (дюйм.)						
			L	J	Jx	E	C	G	F
6	25	FL-GZ6-F25E-4081-	47.5(1.87)	115.0(4.53)	85.0(3.35)	4.8(0.19)	15.3(0.60)	14.0(0.55)	20.0(0.79)
12	15	FL-GZ12-F15E-40B1-	48.5(1.91)	95.0(3.74)	65.0(2.56)	9.5(0.37)	22.8(0.90)	22.0(0.87)	20.0(0.79)
12	25	FL-GZ12-F25E-4081-	50.5(1.99)	115.0(4.53)	85.0(3.35)	9.5(0.37)	22.8(0.90)	22.0(0.87)	20.0(0.79)
12	50	FL-GZ12-F50E-4081-	55.3(2.18)	165.0(6.50)	125.0(4.92)	9.5(0.37)	22.8(0.90)	22.0(0.87)	20.0(0.79)
10	15	FL-GZ18-F15C-40B1-	51.0(2.04)	95.0(3.74)	65.0(2.56)	15.1(0.59)	24.4(0.96)	30.0(1.10)	32.0(1.26)
18	25	FL-GZ18-F25E-4081-	53.8(2.12)	115.0(4.53)	85.0(3.35)	15.1(0.59)	24.4(0.96)	30.0(1.18)	32.0(1.26)
25	25	FL-GZ25-F25E-4081-	64.0(2.52)	115.0(4.53)	85.0(3.35)	21.8(0.86)	31.3(1.23)	38.0(1.50)	35.0(1.38)

### Фланец JIS, Класс давления 10K

Т-Трубка O.D.	JIS Размер фланца DN	Артикул	Размеры, дюйм. (мм)						
			L	J	Jx	E	C	G	F
1/4"	15	FL-YZ4-F15-10KRF-	1.66(42.2)	3.74(95.0)	2.76(70.1)	0.19(4.8)	0.60(15.2)	0.56(14.3)	0.81(20.6)
3/8"	15	FL-YZ6-F15-10KRF-	1.72(43.7)	3.74(95.0)	2.76(70.1)	0.28(7.1)	0.66(16.8)	0.69(17.5)	0.81(20.6)
1/2"	15	FL-YZ8-F15-10KRF-	1.83(46.5)	3.74(95.0)	2.76(70.1)	0.41(10.4)	0.90(22.9)	0.87(22.2)	0.81(20.6)
3/4"	15	FL-YZ12-F15-10KRF-	1.91(48.5)	3.74(95.0)	2.76(70.1)	0.62(15.7)	0.96(24.4)	1.13(28.6)	1.25(31.8)
1"	25	FL-YZ16-F25-10KRF-	2.40(61.0)	4.92(125.0)	3.54(89.9)	0.88(22.4)	1.23(31.2)	1.50(38.1)	1.37(34.9)
12mm	15	FL-GZ12-F15-10KRF-	1.83(46.5)	3.74(95.0)	2.76(70.0)	0.37(9.5)	0.90(22.8)	0.87(22.0)	0.79(20.0)
18mm	15	FL-GZ18-F15-10KRF-	1.91(48.5)	3.74(95.0)	2.76(70.0)	0.59(15.1)	0.96(24.4)	1.18(30.0)	1.26(32.0)
25mm	25	FL-GZ25-F25-10KRF-	2.40(61.0)	4.92(125.0)	3.54(90.0)	0.86(21.8)	1.23(31.3)	1.50(38.0)	1.38(35.0)



## Муфта под приварку

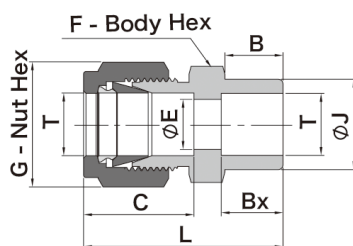

Дюймовая трубка		Приварка в раструб							
Т-Трубка (дюйм.)	Артикул	Размеры, дюйм. (мм)							
		L	C	G	F	B	E	Bx	J
1/8	FUG-YZ2-TS2-	1.14(29.0)	0.50(12.7)	0.44(11.1)	0.44(11.1)	0.34(8.6)	0.09(2.3)	0.10(2.5)	0.31(7.9)
3/16	FUG-YZ3-TS3-	1.17(29.7)	0.54(13.7)	0.50(12.7)	0.44(11.1)	0.37(9.5)	0.13(3.3)	0.19(4.8)	0.42(10.7)
1/4	FUG-YZ4-TS4-	1.32(33.5)	0.60(15.2)	0.56(14.3)	0.50(12.7)	0.41(10.4)	0.19(4.8)	0.28(7.1)	0.48(12.2)
3/8	FUG-YZ6-TS6-	1.48(37.6)	0.66(16.8)	0.69(17.5)	0.63(15.9)	0.47(11.9)	0.28(7.1)	0.31(7.9)	0.62(15.7)
1/2	FUG-YZ8-TS8-	1.62(41.1)	0.90(22.9)	0.87(22.2)	0.81(20.6)	0.47(11.9)	0.41(10.4)	0.50(12.7)	0.75(19.1)
5/8	FUG-YZ10-TS10-	1.65(41.9)	0.96(24.4)	1.00(25.4)	0.94(23.8)	0.47(11.9)	0.50(12.7)	0.41(10.4)	0.92(23.4)
3/4	FUG-YZ12-TS12-	1.71(43.4)	0.96(24.4)	1.13(28.6)	1.06(27.0)	0.47(11.9)	0.62(15.7)	0.44(11.1)	1.05(26.7)
1	FUG-YZ16-TS16-	2.07(52.6)	1.23(31.2)	1.50(38.1)	1.37(34.9)	0.56(14.2)	0.88(22.4)	0.62(15.7)	1.36(34.5)

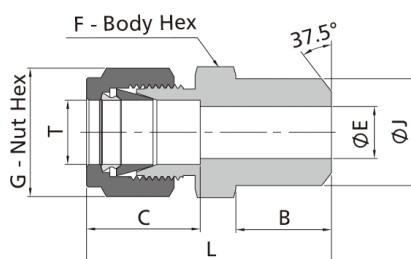

Размер E наименьший номинальный размер.

Дюймовая трубка		Приварка встык							
Т-Трубка (дюйм.)	Размер Трубки под сварку	Артикул	Размеры, дюйм. (мм)						
			L	C	G	F	E	B	J
1/8	1/8	FUG-YZ2-PB2-	1.20(30.5)	1.23(31.2)	1.29(32.8)	1.49(37.8)	1.34(34.0)	1.52(38.6)	1.57(39.9)
3/16	1/8	FUG-YZ3-PB2-	1.57(39.9)	1.82(46.2)	1.88(47.8)	1.71(43.4)	1.93(49.0)	1.99(50.5)	1.93(49.0)
1/4	1/8	FUG-YZ4-PB2-	1.99(50.5)	1.99(50.5)	2.45(62.2)	3.04(77.2)	3.50(88.9)	0.50(12.7)	0.54(13.7)
1/4	1/4	FUG-YZ4-PB4-	0.60(15.2)	0.60(15.2)	0.64(16.3)	0.64(16.3)	0.66(16.8)	0.66(16.8)	0.66(16.8)
5/16	1/8	FUG-YZ5-PB2-	0.66(16.8)	0.90(22.9)	0.90(22.9)	0.90(22.9)	0.96(24.4)	0.96(24.4)	0.96(24.4)
5/16	1/4	FUG-YZ5-PB4-	1.23(31.2)	1.62(41.1)	1.97(50.0)	0.44(11.1)	0.50(12.7)	0.56(14.3)	0.56(14.3)
3/8	1/4	FUG-YZ6-PB4-	0.63(15.9)	0.63(15.9)	0.69(17.5)	0.69(17.5)	0.69(17.5)	0.69(17.5)	0.87(22.2)
3/8	3/8	FUG-YZ6-PB6-	0.87(22.2)	0.87(22.2)	1.00(25.4)	1.13(28.6)	1.13(28.6)	1.50(38.1)	1.87(47.6)
3/8	1/2	FUG-YZ6-PB8-	2.25(57.2)	0.44(11.1)	0.44(11.1)	0.50(12.7)	0.56(14.3)	0.56(14.3)	0.56(14.3)
3/8	3/4	FUG-YZ6-PB12-	0.63(15.9)	0.69(17.5)	0.87(22.2)	1.06(27.0)	0.81(20.6)	0.87(22.2)	1.06(27.0)
1/2	3/8	FUG-YZ8-PB6-	0.94(23.8)	1.06(27.0)	1.06(27.0)	1.37(34.9)	1.75(44.5)	2.13(54.0)	0.09(2.3)
1/2	1/2	FUG-YZ8-PB8-	0.12(3.0)	0.19(4.8)	0.19(4.8)	0.21(5.3)	0.25(6.4)	0.28(7.1)	0.28(7.1)
1/2	3/4	FUG-YZ8-PB12-	0.28(7.1)	0.28(7.1)	0.41(10.4)	0.41(10.4)	0.41(10.4)	0.50(12.7)	0.55(14.0)
5/8	1/2	FUG-YZ10-PB8-	0.62(15.7)	0.88(22.4)	1.09(27.7)	1.34(34.0)	0.38(9.7)	0.38(9.7)	0.38(9.7)
3/4	1/2	FUG-YZ12-PB8-	0.56(14.2)	0.38(9.7)	0.56(14.2)	0.56(14.2)	0.56(14.2)	0.75(19.1)	0.75(19.1)
3/4	3/4	FUG-YZ12-PB12-	0.56(14.2)	0.75(19.1)	0.75(19.1)	0.75(19.1)	0.75(19.1)	0.75(19.1)	0.94(23.9)
1	1	FUG-YZ16-PB16-	0.94(23.9)	1.03(26.2)	0.41(10.3)	0.41(10.3)	0.41(10.3)	0.54(13.7)	0.41(10.3)
1 1/4	1 1/4	FUG-YZ20-PB20-	0.54(13.7)	0.54(13.7)	0.67(17.1)	0.84(21.3)	1.05(26.7)	0.67(17.1)	0.84(21.3)
1 1/2	1 1/2	FUG-YZ24-PB24-	1.05(26.7)	0.84(21.3)	0.84(21.3)	1.05(26.7)	1.31(33.4)	1.66(42.2)	1.90(48.3)

# Размеры

## Муфта под приварку

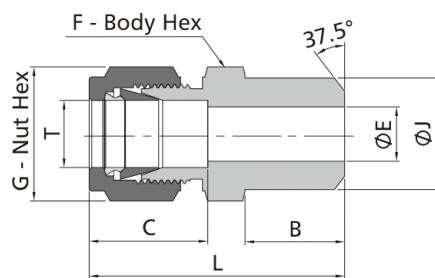

Размер E наименьший номинальный размер.

### Метрическая трубка

### Приварка встык

Т-Трубка (мм.)	Размер Трубки под сварку	Артикул	Размеры, дюйм. (мм)						
			L	C	G	F	E	B	J
3	1/8	FUG-GZ3-PB2-	30.5(1.20)	12.9(0.51)	12.0(0.47)	12.0(0.47)	2.4(0.09)	9.7(0.38)	10.3(0.41)
4	1/8	FUG-GZ4-PB2-	31.5(1.24)	13.7(0.54)	12.0(0.47)	12.0(0.47)	2.4(0.09)	9.7(0.38)	10.3(0.41)
6	1/8	FUG-GZ6-PB2-	32.8(1.29)	15.3(0.60)	14.0(0.55)	14.0(0.55)	4.8(0.19)	9.7(0.38)	10.3(0.41)
6	1/4	FUG-GZ6-PB4-	37.9(1.49)	15.3(0.60)	14.0(0.55)	14.0(0.55)	4.8(0.19)	14.2(0.56)	13.7(0.54)
8	1/8	FUG-GZ8-PB2-	34.2(1.35)	16.2(0.64)	16.0(0.63)	15.0(0.59)	5.4(0.21)	9.7(0.38)	10.3(0.41)
8	1/4	FUG-GZ8-PB4-	38.7(1.52)	16.2(0.64)	16.0(0.63)	15.0(0.59)	6.4(0.25)	14.2(0.56)	13.7(0.54)
8	1/2	FUG-GZ8-PB8-	45.6(1.80)	16.2(0.64)	16.0(0.63)	22.0(0.87)	6.4(0.25)	19.1(0.75)	21.3(0.84)
10	1/4	FUG-GZ10-PB4-	40.9(1.60)	17.2(0.70)	19.0(0.75)	18.0(0.71)	7.5(0.30)	14.2(0.56)	13.7(0.54)
10	3/8	FUG-GZ10-PB6-	40.9(1.60)	17.2(0.70)	19.0(0.75)	18.0(0.71)	7.9(0.31)	14.2(0.56)	17.1(0.67)
10	1/2	FUG-GZ10-PB8-	46.5(1.80)	17.2(0.70)	19.0(0.75)	22.0(0.87)	7.9(0.31)	19.1(0.75)	21.3(0.84)
12	1/4	FUG-GZ12-PB4-	43.4(1.70)	22.8(0.90)	22.0(0.87)	22.0(0.87)	7.5(0.30)	14.2(0.56)	13.7(0.54)
12	3/8	FUG-GZ12-PB6-	43.4(1.70)	22.8(0.90)	22.0(0.87)	22.0(0.87)	9.5(0.37)	14.2(0.56)	17.1(0.67)
12	1/2	FUG-GZ12-PB8-	49.0(1.90)	22.8(0.90)	22.0(0.87)	22.0(0.87)	9.5(0.37)	19.1(0.75)	21.3(0.84)
14	3/8	FUG-GZ14-PB6-	44.1(1.70)	24.4(0.96)	25.0(0.98)	24.0(0.94)	10.7(0.42)	14.2(0.56)	17.1(0.67)
15	1/2	FUG-GZ15-PB8-	49.0(1.90)	24.4(0.96)	25.0(0.98)	24.0(0.94)	11.9(0.47)	19.1(0.75)	21.3(0.84)
16	1/2	FUG-GZ16-PB8-	49.0(1.90)	24.4(0.96)	25.0(0.98)	24.0(0.94)	12.7(0.50)	19.1(0.75)	21.3(0.84)
18	1/2	FUG-GZ18-PB8-	50.5(2.00)	24.4(0.96)	30.0(1.18)	27.0(1.06)	13.9(0.55)	19.1(0.75)	21.3(0.84)
30	1 1/4	FUG-GZ30-PB20-	77.2(3.00)	39.6(1.60)	50.0(1.97)	46.0(1.81)	26.2(1.03)	23.9(0.94)	42.2(1.66)
32	1 1/4	FUG-GZ32-PB20-	79.6(3.10)	42.0(1.70)	50.0(1.97)	46.0(1.81)	28.6(1.13)	23.9(0.94)	42.2(1.66)
38	1 1/2	FUG-GZ38-PB24-	91.6(3.60)	49.4(1.90)	60.0(2.36)	55.0(2.17)	33.7(1.33)	26.2(1.03)	48.3(1.9)

## Угольник под приварки

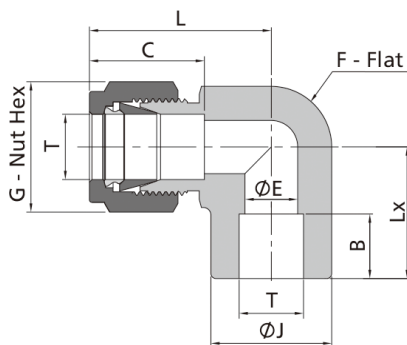

### Дюймовая трубка

### Привырка в раструб

Т-Трубка (мм.)	Артикул	Размеры, дюйм. (мм)							
		L	C	G	F	B	E	Lx	J
1/8	FYG-YZ2-TS2-	0.66(16.8)	0.50(12.7)	0.44(11.1)	0.37(9.5)	0.10(2.5)	0.09(2.3)	0.63(16.0)	0.38(9.7)
3/16	FYG-YZ3-TS3-	0.72(18.3)	0.54(13.7)	0.50(12.7)	0.44(11.1)	0.19(4.8)	0.13(3.3)	0.69(17.5)	0.44(11.2)
1/4	FYG-YZ4-TS4-	1.06(26.9)	0.60(15.2)	0.56(14.3)	0.50(12.7)	0.28(7.1)	0.19(4.8)	0.77(19.6)	0.50(12.7)
3/8	FYG-YZ6-TS6-	1.20(30.5)	0.66(16.8)	0.69(17.5)	0.63(15.9)	0.31(7.9)	0.28(7.1)	0.91(23.1)	0.62(15.7)
1/2	FYG-YZ8-TS8-	1.42(36.1)	0.90(22.9)	0.87(22.2)	0.81(20.6)	0.38(9.7)	0.41(10.4)	1.02(25.9)	0.81(20.6)
5/8	FYG-YZ10-TS10-	1.16(29.5)	0.96(24.4)	1.00(25.4)	1.06(27.0)	0.41(10.4)	0.50(12.7)	1.16(29.5)	0.94(23.9)
3/4	FYG-YZ12-TS12-	1.57(39.9)	0.96(24.4)	1.13(28.6)	1.06(27.0)	0.44(11.2)	0.62(15.7)	1.17(29.7)	1.06(26.9)
1	FYG-YZ16-TS16-	1.93(49.0)	1.23(31.2)	1.50(38.1)	1.37(34.9)	0.62(15.7)	0.88(22.4)	1.45(36.8)	1.38(35.1)

## Угольник под приварку

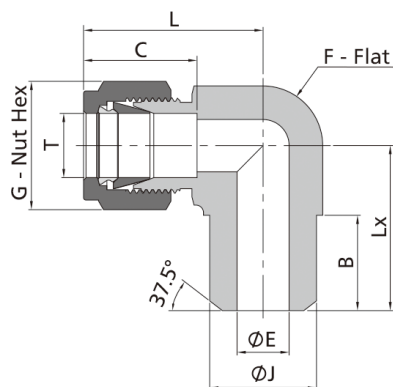

Fractional Tube			Приварка встык							
Т-Трубка (дюйм.)	Размер Трубки под сварку	Артикул	Размеры, дюйм. (мм)							
			L	C	G	F	B	E	Lx	J
1/8	1/8	FYG-YZ2-PB2-	0.92(23.4)	0.50(12.7)	0.44(11.1)	0.44(11.1)	0.38(9.7)	0.09(2.3)	0.72(18.3)	0.41(10.3)
3/16	1/8	FYG-YZ3-PB2-	1.01(25.7)	0.54(13.7)	0.50(12.7)	0.50(12.7)	0.38(9.7)	0.12(3.0)	0.74(18.8)	0.41(10.3)
1/4	1/8	FYG-YZ4-PB2-	1.06(26.9)	0.60(15.2)	0.56(14.3)	0.50(12.7)	0.38(9.7)	0.19(4.8)	0.74(18.8)	0.41(10.3)
1/4	1/4	FYG-YZ4-PB4-	1.06(26.9)	0.60(15.2)	0.56(14.3)	0.50(12.7)	0.56(14.2)	0.19(4.8)	0.92(23.4)	0.54(13.7)
3/8	1/4	FYG-YZ6-PB4-	1.20(30.5)	0.66(16.8)	0.69(17.5)	0.63(15.9)	0.56(14.2)	0.28(7.1)	1.00(25.4)	0.54(13.7)
1/2	3/8	FYG-YZ8-PB6-	1.37(34.8)	0.90(22.9)	0.87(22.2)	0.81(20.6)	0.56(14.2)	0.41(10.4)	1.13(28.8)	0.67(17.1)
1/2	1/2	FYG-YZ8-PB8-	1.42(36.1)	0.90(22.9)	0.87(22.2)	0.81(20.6)	0.75(19.1)	0.41(10.4)	1.30(33.0)	0.84(21.3)
5/8	1/2	FYG-YZ10-PB8-	1.43(36.3)	0.96(24.4)	1.00(25.4)	0.94(23.8)	0.75(19.1)	0.50(12.7)	1.38(35.1)	0.84(21.3)
3/4	3/4	FYG-YZ12-PB12-	1.57(39.9)	0.96(24.4)	1.13(28.6)	1.06(27.0)	0.75(19.1)	0.62(15.7)	1.45(36.8)	1.05(26.7)
1	3/4	FYG-YZ16-PB12-	1.94(49.3)	1.23(31.2)	1.50(38.1)	1.37(34.9)	0.75(19.1)	0.74(18.8)	1.65(41.9)	1.05(26.7)
1	1	FYG-YZ16-PB16-	1.94(49.3)	1.23(31.2)	1.50(38.1)	1.37(34.9)	0.94(23.9)	0.88(22.4)	1.84(46.7)	1.31(33.4)

## Фитинг калибровочный

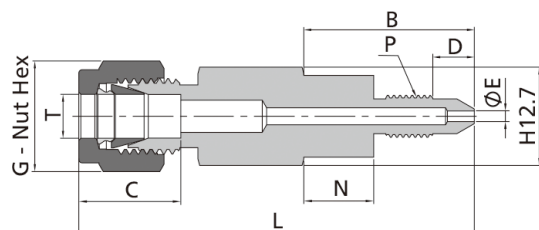

- Калибровочные фитинги можно подсоединить непосредственно к отверстию преобразователя, что упрощает процесс калибровки.
- Доступны два типа, подходящие для отверстий датчиков.

Дюймовая трубка			Приварка встык						
Т-Трубка (дюйм.)	P-SAE /MS Размер резьбы	Артикул	Размеры, дюйм. (мм)						
			L	B	C	D	E	G	N
1/4	1/4-28	FYC-YZ4-1428-	1.69(42.9)	0.78(19.8)	0.60(15.2)	0.43(10.9)	0.06(1.5)	0.56(14.3)	—
1/4	5/16-24	FYC-YZ4-51624-	2.32(58.9)	1.41(35.8)	0.60(15.2)	0.40(10.2)	0.06(1.5)	0.56(14.3)	0.41(10.4)

## Прокладки RS, RSD

RS



RSD



Прокладки RS и RSD обеспечивают уплотнение цилиндрической резьбы ISO. Прокладка состоит из внутреннего кольца из фторуглерода FKM, соединенного с наружным кольцом из углеродистой или нержавеющей стали.

Цилиндрическая резьба ISO	Артикул	Размеры дюйм. (мм)			
		T	E	H	
1/8	FV1-2-	0.63(16.0)	0.41(10.4)	0.08(2.0)	
1/4	FV1-4-	0.81(20.6)	0.54(13.7)		
3/8	FV1-6-	0.94(23.9)	0.68(17.3)		
1/2	FV1-8-	1.13(28.7)	0.85(21.6)	0.10(2.5)	
3/4	FV1-12-	1.38(35.1)	1.06(26.9)		
1	FV1-16-	1.69(42.9)	1.33(33.8)		
1/8	FV1D-2-	0.58(14.7)	0.47(12)	0.05(1.25)	
1/4	FV1D-4-	0.74(18.7)	0.62(15.75)		
3/8	FV1D-6-	0.89(22.7)	0.76(19.25)		
1/2	FV1D-8-	1.05(26.7)	0.93(23.55)	0.08(2)	
3/4	FV1D-12-	1.28(32.5)	1.15(29.2)		
1	FV1D-16-	1.56(39.5)	1.42(36.1)		

## Прокладка RS, RSD

Метрическая резьба	Артикул	Размеры мм. (дюйм)			
		T	E	H	
M8 × 1	FV1-M8-	13.0(0.51)	8.7(0.34)	1.0(0.04)	
M10 × 1	FV1-M10-	16.0(0.63)	10.7(0.42)		
M12 × 1.5	FV1-M12-	18.0(0.63)	12.7(0.42)		
M14 × 1.5	FV1-M14-	22.0(0.71)	14.7(0.50)	1.5(0.06)	
M16 × 1.5	FV1-M16-	24.0(0.87)	16.7(0.66)		
M18 × 1.5	FV1-M18-	26.0(0.94)	18.7(0.74)		
M20 × 1.5	FV1-M20-	28.0(1.02)	20.7(0.81)	2.0(0.08)	
M22 × 1.5	FV1-M22-	30.0(1.10)	22.7(0.89)		
M24 × 1.5	FV1-M24-	32.0(1.20)	24.7(1.00)		
M27 × 2	FV1-M27-	36.0(1.30)	27.2(1.10)	2.0(0.08)	
M30 × 2	FV1-M30-	39.0(1.40)	30.7(1.20)		
M33 × 2	FV1-M33-	42.0(1.50)	33.7(1.30)		
M36 × 2	FV1-M36-	48.0(1.70)	37.0(1.50)	2.5(0.10)	
M39 × 2	FV1-M39-	51.0(1.90)	40.0(1.60)		
M42 × 2	FV1-M42-	53.0(2.00)	42.7(1.70)		
M45 × 2	FV1-M45-	57.0(2.10)	46.0(1.80)	3.0(0.12)	
M48 × 2	FV1-M48-	59.0(2.20)	48.7(1.90)		

## Информация для заказа

Добавьте обозначение материала в качестве префикса к основному заказу

Кольцо		Обозначение
Внешнее	Внутреннее	
Нержавеющая сталь	FKM	SSF
Углеродистая сталь	FKM	CSF
	Резина-N	CSB

## Пример:

1. Прокладка RS с внутренним кольцом из резины, соединенная с наружным кольцом из углеродистой стали, для обеспечения уплотнения цилиндрической резьбы ISO 1/8. Полный номер заказа: **CSB-FV1-2.**

2. Прокладка RSD с внутренним кольцом из FKM и внешним кольцом из нержавеющей стали, обеспечивает уплотнение с наружной цилиндрической резьбой ISO 1/4, полный номер заказа: **SSF-FV1D-4.** Прокладки RS и RSD можно использовать только с фитингом RS.

## Прокладка RP

Прокладка RP обеспечивает уплотнение с наружной цилиндрической резьбой ISO. Прокладка RP может использоваться с фитингом RS.



Цилиндрическая резьба ISO	Артикул	Размеры дюйм. (мм)			
		T	E	H	
1/8	FV2-2-	0.59(15.0)	0.39(9.9)	0.04(1.0)	
1/4	FV2-4-	0.75(19.1)	0.52(13.2)		
3/8	FV2-6-	0.91(23.1)	0.66(16.8)		
1/2	FV2-8-	1.06(26.9)	0.83(21.1)	0.06(1.5)	
3/4	FV2-12-	1.30(33.0)	1.05(26.7)		
1	FV2-16-	1.58(40.1)	1.31(33.2)		

## Прокладка RP-M

Метрическая резьба	Артикул	Размеры мм. (дюйм)			
		T	E	H	
M8 × 1	FV2-M8-	13.2(0.52)	8.2(0.32)	1.5(0.06)	
M10 × 1	FV2-M10-	15.2(0.60)	10.2(0.40)		
M12 × 1.5	FV2-M12-	18.2(0.60)	12.2(0.40)		
M14 × 1.5	FV2-M14-	20.2(0.72)	14.2(0.48)	2.0(0.08)	
M16 × 1.5	FV2-M16-	22.2(0.80)	16.2(0.64)		
M18 × 1.5	FV2-M18-	24.2(0.87)	18.2(0.72)		
M20 × 1.5	FV2-M20-	26.2(0.95)	20.2(0.80)	2.0(0.08)	
M22 × 1.5	FV2-M22-	28.2(1.03)	22.2(0.87)		
M24 × 1.5	FV2-M24-	30.2(1.10)	24.2(1.00)		
M27 × 2	FV2-M27-	33.3(1.20)	27.2(1.10)	2.5(0.10)	
M30 × 2	FV2-M30-	37.3(1.30)	30.2(1.20)		
M33 × 2	FV2-M33-	40.3(1.50)	33.2(1.30)		
M36 × 2	FV2-M36-	43.3(1.60)	36.2(1.40)	2.5(0.10)	
M39 × 2	FV2-M39-	47.3(1.70)	39.2(1.50)		
M42 × 2	FV2-M42-	50.3(1.90)	42.2(1.70)		
M45 × 2	FV2-M45-	53.3(2.00)	45.2(1.80)	3.0(0.12)	
M48 × 2	FV2-M48-	56.3(2.10)	48.2(1.90)		

## RG Gaskets

Прокладка RG обеспечивает герметизацию манометров с наружной цилиндрической резьбой ISO.

Цилиндрическая резьба ISO	Артикул	Размеры дюйм. (мм)		
		T	E	H
1/4	FV3-4-	0.42(10.7)	0.30(7.6)	0.07(1.8)
3/8	FV3-6-	0.56(14.2)	0.34(8.6)	0.09(2.3)
1/2	FV3-8-	0.70(17.8)	0.36(9.1)	0.10(2.5)

## RG-M Gaskets

Метрическая резьба	Артикул	Размеры мм. (дюйм)		
		T	E	H
M10 × 1	FV3-M10-	8.3(0.33)	3.3(0.13)	1.5(0.06)
M12 × 1.5	FV3-M12-	9.7(0.38)	5.4(0.21)	
M14 × 1.5	FV3-M14-	11.7(0.38)	6.4(0.21)	
M16 × 1.5	FV3-M16-	13.7(0.46)	8.4(0.25)	
M18 × 1.5	FV3-M18-	15.7(0.54)	10.0(0.39)	
M20 × 1.5	FV3-M20-	17.6(0.62)	11.4(0.45)	
M22 × 1.5	FV3-M22-	19.6(0.69)	13.4(0.53)	2.0(0.08)
M24 × 1.5	FV3-M24-	21.6(0.77)	14.8(0.58)	
M27 × 2	FV3-M27-	24.0(0.90)	13.9(0.50)	
M30 × 2	FV3-M30-	27.0(0.90)	19.5(0.80)	
M33 × 2	FV3-M33-	30.0(1.10)	21.5(0.80)	
M36 × 2	FV3-M36-	33.0(1.20)	23.5(0.90)	
M39 × 2	FV3-M39-	36.0(1.30)	24.5(1.00)	
M42 × 2	FV3-M42-	38.9(1.40)	29.5(1.20)	
M45 × 2	FV3-M45-	41.9(1.50)	30.0(1.20)	
M48 × 2	FV3-M48-	44.9(1.60)	32.5(1.30)	

## RJ Gaskets

Прокладка RJ обеспечивает герметизацию японских манометров с наружной цилиндрической резьбой ISO.

Цилиндрическая резьба ISO	Артикул	Размеры дюйм. (мм)		
		T	E	H
1/4	FV4-4-	0.43(10.9)	0.22(5.6)	0.04(1.0)
3/8	FV4-6-	0.55(13.9)	0.22(5.6)	0.04(1.0)
1/2	FV4-8-	0.70(17.8)	0.22(5.6)	0.04(1.0)

## Информация для заказа

Полный номер заказа должен быть составлен путем добавления кода материала.

Материал	Обозначение
Медь	CU
Нержавеющая сталь 316L SS	SL
Фибра	QB
PTFE	T

Фибру and PTFE нельзя использовать для прокладки RP

**Пример:**  
FV2-2-CU,FV3-6-SL,FV3-M20-QB

## O-rings



Уплотнительные кольца для фитингов с прямой резьбой SAE/MS

SAE/MS Резьба	Артикул	Материал
5/16-24	FV-VI9-903-	90 дюрометр Флюорокарбон FKM
3/8-24	FV-VI9-904-	
7/16-20	FV-VI9-905-	
1/2-20	FV-VI9-906-	
9/16-18	FV-VI9-908-	
3/4-16	FV-VI9-910-	
7/8-14	FV-VI9-912-	
1 1/16-12	FV-VI9-914-	
1 3/16-12	FV-VI9-916-	
1 5/16-12	FV-VI9-920-	
1 5/8-12	FV-VI9-924-	
1 7/8-12	FV1-924-	

Уплотнительные кольца для фитингов с трубной резьбой и уплотнительным кольцом

SAE/MS Резьба	Артикул	Материал
1/8	FV-BN7-013-	70 дюрометр NBR
1/4	FV-BN7-113-	
3/8	FV-BN7-116-	
1/2	FV-BN7-118-	

## Размеры

Уплотнительные кольца для позиционируемых фитингов с цилиндрической резьбой ISO

Цилиндрическая резьба ISO	Артикул	Материал
1/8	FV-VI9-502-	90 дюрометр Флюорокарбон FKM
1/4	FV-VI9-111-	
3/8	FV-VI9-113-	
1/2	FV-VI9-508-	
3/4	FV-VI9-119-	
1	FV-VI9-217-	

Уплотнительные кольца для фитингов с прямой резьбой с уплотнительным кольцом

Цилиндрическая резьба SAE/MS	Артикул	Материал
5/16-24	FV-BN7-011-	70 дюрометр NBR
3/8-24	FV-BN7-012-	
7/16-20	FV-BN7-013-	
1/2-20	FV-BN7-112-	
9/16-18	FV-BN7-113-	
3/4-16	FV-BN7-116-	
1 1/16-12	FV-BN7-121-	
1 5/16-12	FV-BN7-125-	

Уплотнительные кольца для фитингов с метрической резьбой

Метрическая резьба	Артикул	Материал
M14 × 1.5	FV-BN9-M14-	90 дюрометр NBR
M20 × 1.5	FV-BN9-M20-	



